

# TP, TPD

## Installation and operating instructions

GB D F I E P GR NL S FIN DK  
PL RU H SI HR SER RO BG CZ SK EE



## **(GB)** Declaration of Conformity

We **Grundfos** declare under our sole responsibility that the products **TP** and **TPD**, to which this declaration relates, are in conformity with the Council Directives on the approximation of the laws of the EC Member States relating to

- Machinery (98/37/EC).  
Standard used: EN 809.
- Electrical equipment designed for use within certain voltage limits (2006/95/EC).  
Standards used: MG, MMG, Siemens, Teco: EN 60204-1, EN 60034-1 and EN 60034-5; MMGE: EN 61800-2.
- Electromagnetic compatibility (2004/108/EC).  
Standards used: MG, MMG, Siemens, Teco: EN 61000-6-2 and EN 61000-6-3; MGE/MMGE: EN 61800-3.
- ATEX 94/9/EC (applies only to products with the ATEX mark on the nameplate).  
Standards used: EN 13463-1 and EN 13463-5.  
(Declaration of conformity and installation and operating instructions of the motor are enclosed.)

### **Pump without motor**

We **Grundfos** declare under our sole responsibility that the products **TP** and **TPD**, to which this declaration relates, are in conformity with the Council Directives on the approximation of the laws of the EC Member States relating to

- Machinery (98/37/EC) and meet Annex II B.  
Standard used: EN 809.

Before the pump is taken into operation, the complete machinery into which the pump is to be incorporated must be declared in accordance with all relevant regulations.

## **(F)** Déclaration de Conformité

Nous **Grundfos** déclarons sous notre seule responsabilité que les produits **TP** et **TPD** auxquels se réfère cette déclaration sont conformes aux Directives du Conseil concernant le rapprochement des législations des Etats membres CE relatives à

- Machines (98/37/CE).  
Standard utilisé: EN 809.
- Matériel électrique destiné à employer dans certaines limites de tension (2006/95/CE).  
Standards utilisés: MG, MMG, Siemens, Teco: EN 60204-1, EN 60034-1 et EN 60034-5; MMGE: EN 61800-2.
- Compatibilité électromagnétique (2004/108/CE).  
Standards utilisés: MG, MMG, Siemens, Teco: EN 61000-6-2 et EN 61000-6-3; MGE/MMGE: EN 61800-3.
- ATEX 94/9/CE (s'applique uniquement aux produits avec norme ATEX citée sur la plaque signalétique).  
Standards utilisés: EN 13463-1 et EN 13463-5.  
(Déclaration de conformité et notice d'installation et d'entretien du moteur incluses.)

### **Pompe sans moteur**

Nous **Grundfos** déclarons sous notre seule responsabilité que les produits **TP** et **TPD** auxquels se réfère cette déclaration sont conformes aux Directives du Conseil concernant le rapprochement des législations des Etats membres CE relatives à

- Relatif aux machines (98/37/CE) et conforme à l'Annexe II B.  
Standard utilisé: EN 809.

Avant que la pompe ne soit mise en service, la machine complète, dans laquelle sera incorporée la pompe, doit être en accord avec toutes les réglementations en vigueur.

## **(D)** Konformitätserklärung

Wir **Grundfos** erklären in alleiniger Verantwortung, dass die Produkte **TP** und **TPD**, auf die sich diese Erklärung bezieht, mit den folgenden Richtlinien des Rates zur Angleichung der Rechtsvorschriften der EG-Mitgliedstaaten übereinstimmen:

- Maschinen (98/37/EG).  
Norm, die verwendet wurde: EN 809.
- Elektrische Betriebsmittel zur Verwendung innerhalb bestimmter Spannungsgrenzen (2006/95/EG).  
Normen, die verwendet wurden: MG, MMG, Siemens, Teco: EN 60204-1, EN 60034-1 und EN 60034-5; MMGE: EN 61800-2.
- Elektromagnetische Verträglichkeit (2004/108/EG).  
Normen, die verwendet wurden: MG, MMG, Siemens, Teco: EN 61000-6-2 und EN 61000-6-3; MGE/MMGE: EN 61800-3.
- ATEX 94/9/EG (gilt nur für Produkte mit der ATEX-Kennzeichnung auf dem Leistungsschild).  
Normen, die verwendet wurden: EN 13463-1 und EN 13463-5.  
(Die Konformitätsbescheinigung und Montage- und Betriebsanleitung vom Motor sind beigelegt.)

### **Pumpe ohne Motor**

Wir **Grundfos** erklären in alleiniger Verantwortung, dass die Produkte **TP** und **TPD**, auf die sich diese Erklärung bezieht, mit den folgenden Richtlinien des Rates zur Angleichung der Rechtsvorschriften der EG-Mitgliedstaaten übereinstimmen:

- Maschinen (98/37/EG), Anhang II B (Herstellereklärung).  
Norm, die verwendet wurde: EN 809.

Vor der Inbetriebnahme der Pumpe ist eine Konformitätserklärung für die gesamte Anlage, in die die Baugruppe "Pumpe mit freiem Wellenende" eingebaut ist, auszustellen.

## **(I)** Dichiarazione di Conformità

Noi **Grundfos** dichiariamo sotto la nostra esclusiva responsabilità che i prodotti **TP** e **TPD** ai quali questa dichiarazione se riferisce sono conformi alle Direttive del Consiglio concernente il ravvicinamento delle legislazioni degli Stati membri CE relative a

- Macchine (98/37/CE).  
Standard usato: EN 809.
- Materiale elettrico destinato ad essere utilizzato entro certi limiti di tensione (2006/95/CE).  
Standard usati: MG, MMG, Siemens, Teco: EN 60204-1, EN 60034-1 e EN 60034-5; MMGE: EN 61800-2.
- Compatibilità elettromagnetica (2004/108/CE).  
Standard usati: MG, MMG, Siemens, Teco: EN 61000-6-2 e EN 61000-6-3; MGE/MMGE: EN 61800-3.
- ATEX 94/9/CE (si applica solo ai prodotti che riportano la sigla ATEX sull'etichetta).  
Standard usati: EN 13463-1 e EN 13463-5.  
(In allegato la dichiarazione di conformità e il manuale di installazione e funzionamento.)

### **Pompa senza motore**

Noi **Grundfos** dichiariamo sotto la nostra esclusiva responsabilità che i prodotti **TP** e **TPD** ai quali questa dichiarazione se riferisce sono conformi alle Direttive del Consiglio concernente il ravvicinamento delle legislazioni degli Stati membri CE relative a

- Direttiva Macchine (98/37/CE) e Annex II B.  
Standard usato: EN 809.

Si ricorda che se la pompa è inserita in un sistema, prima di avviare la pompa stessa, è necessario che tutto il sistema sia in accordo alle norme di riferimento.

## **(E) Declaración de Conformidad**

Nosotros **Grundfos** declaramos bajo nuestra única responsabilidad que los productos **TP** y **TPD** a los cuales se refiere esta declaración son conformes con las Directivas del Consejo relativas a la aproximación de las legislaciones de los Estados Miembros de la CE sobre

- Máquinas (98/37/CE).  
Norma aplicada: EN 809.
- Material eléctrico destinado a utilizarse con determinados límites de tensión (2006/95/CE).  
Normas aplicadas: MG, MMG, Siemens, Teco: EN 60204-1, EN 60034-1 y EN 60034-5; MMGE: EN 61800-2.
- Compatibilidad electromagnética (2004/108/CE).  
Normas aplicadas: MG, MMG, Siemens, Teco: EN 61000-6-2 y EN 61000-6-3; MGE/MMGE: EN 61800-3.
- ATEX 94/9/CE (se refiere sólo a productos con la marca ATEX en la placa de características).  
Normas aplicadas: EN 13463-1 y EN 13463-5.  
(Se adjuntan la declaración de conformidad e instrucciones de instalación y funcionamiento del motor.)

### **Bomba sin motor**

Nosotros **Grundfos** declaramos bajo nuestra única responsabilidad que los productos **TP** y **TPD** a los cuales se refiere esta declaración son conformes con las Directivas del Consejo relativas a la aproximación de las legislaciones de los Estados Miembros de la CE sobre

- Maquinaria (98/37/CE) y cumple con Anexo II B.  
Norma aplicada: EN 809.

Antes de la puesta en marcha de la bomba, todo el sistema en que la bomba va a incorporarse, debe estar de acuerdo con todas las normativas en vigor.

## **(P) Declaração de Conformidade**

Nós **Grundfos** declaramos sob nossa única responsabilidade que os produtos **TP** e **TPD** aos quais se refere esta declaração estão em conformidade com as Directivas do Conselho das Comunidades Europeias relativas à aproximação das legislações dos Estados Membros respeitantes à

- Máquinas (98/37/CE).  
Norma utilizada: EN 809.
- Material eléctrico destinado a ser utilizado dentro de certos limites de tensão (2006/95/CE).  
Normas utilizadas: MG, MMG, Siemens, Teco: EN 60204-1, EN 60034-1 e EN 60034-5; MMGE: EN 61800-2.
- Compatibilidade electromagnética (2004/108/CE).  
Normas utilizadas: MG, MMG, Siemens, Teco: EN 61000-6-2 e EN 61000-6-3; MGE/MMGE: EN 61800-3.
- ATEX 94/9/CE (apenas aplicável a produtos com a inscrição ATEX gravada na chapa de características).  
Normas utilizadas: EN 13463-1 e EN 13463-5.  
(Em anexo encontra a Declaração de conformidade e instruções de instalação e funcionamento do motor.)

### **Bomba sem motor**

Nós **Grundfos** declaramos sob nossa única responsabilidade que os produtos **TP** e **TPD** aos quais se refere esta declaração estão em conformidade com as Directivas do Conselho das Comunidades Europeias relativas à aproximação das legislações dos Estados Membros respeitantes à

- Maquinaria (98/37/CE) e respeitam o Anexo II B.  
Norma utilizada: EN 809.

Antes de colocar a bomba em operação, o equipamento no qual a mesma irá ser incorporada deve ser declarado de acordo com todas as regulamentações relevantes.

## **(GR) Δήλωση Συμμόρφωσης**

Εμείς η **Grundfos** δηλώνουμε με αποκλειστικά δική μας ευθύνη ότι τα προϊόντα **TP** και **TPD** συμμορφώνονται με την Οδηγία του Συμβουλίου επί της σύγκλισης των νόμων των Κρατών Μελών της Ευρωπαϊκής Ένωσης σε σχέση με τα

- Μηχανήματα (98/37/EC).  
Πρότυπο που χρησιμοποιήθηκε: EN 809.
- Ηλεκτρικές συσκευές σχεδιασμένες για χρήση εντός ορισμένων ορίων ηλεκτρικής τάσης (2006/95/EC).  
Πρότυπα που χρησιμοποιήθηκαν: MG, MMG, Siemens, Teco: EN 60204-1, EN 60034-1 και EN 60034-5; MMGE: EN 61800-2.
- Ηλεκτρομαγνητική συμβατότητα (2004/108/EC).  
Πρότυπα που χρησιμοποιήθηκαν: MG, MMG, Siemens, Teco: EN 61000-6-2 και EN 61000-6-3; MGE/MMGE: EN 61800-3.
- ATEX 94/9/CE (εφαρμόζεται μόνο σε προϊόντα με το σήμα ATEX στην πινακίδα τους).  
Πρότυπα που χρησιμοποιήθηκαν: EN 13463-1 και EN 13463-5.  
(Περιλαμβάνονται δήλωση συμμόρφωσης και οδηγίες εγκατάστασης και λειτουργίας του κινητήρα.)

### **Αντλία χωρίς κινητήρα**

Εμείς η **Grundfos** δηλώνουμε με αποκλειστικά δική μας ευθύνη ότι τα προϊόντα **TP** και **TPD** συμμορφώνονται με την Οδηγία του Συμβουλίου επί της σύγκλισης των νόμων των Κρατών Μελών της Ευρωπαϊκής Ένωσης σε σχέση με τα

- Μηχανήματα (98/37/EC) και σύμφωνα με Annex II B.  
Πρότυπο που χρησιμοποιήθηκε: EN 809.

Πριν η αντλία τεθεί σε λειτουργία, όλο το μηχανήμα στο οποίο η αντλία πρόκειται να ενσωματωθεί πρέπει να δηλωθεί σύμφωνα με όλους τους σχετικούς κανονισμούς.

## **(NL) Overeenkomstigheidsverklaring**

Wij **Grundfos** verklaren geheel onder eigen verantwoordelijkheid dat de producten **TP** en **TPD** waarop deze verklaring betrekking heeft in overeenstemming zijn met de Richtlijnen van de Raad inzake de onderlinge aanpassing van de wetgevingen van de Lid-Staten betreffende

- Machines (98/37/EG).  
Norm: EN 809.
- Elektrisch materiaal bestemd voor gebruik binnen bepaalde spanningsgrenzen (2006/95/EG).  
Normen: MG, MMG, Siemens, Teco: EN 60204-1, EN 60034-1 en EN 60034-5; MMGE: EN 61800-2.
- Elektromagnetische compatibiliteit (2004/108/EG).  
Normen: MG, MMG, Siemens, Teco: EN 61000-6-2 en EN 61000-6-3; MGE/MMGE: EN 61800-3.
- ATEX 94/9/EG (alleen van toepassing voor producten met de ATEX marking op de typeplaat).  
Normen: EN 13463-1 en EN 13463-5.  
(Overeenkomstigheidsverklaring is ingesloten in de installatie- en bedieningsinstructies van de motor.)

### **Pomp zonder motor**

Wij **Grundfos** verklaren geheel onder eigen verantwoordelijkheid dat de producten **TP** en **TPD** waarop deze verklaring betrekking heeft in overeenstemming zijn met de Richtlijnen van de Raad inzake de onderlinge aanpassing van de wetgevingen van de Lid-Staten betreffende

- Machines (98/37/EG) voldoende aan Annex II B.  
Norm: EN 809.

Voordat de pomp in gebruik wordt genomen, moet de gehele installatie waarin de pomp zich bevindt overeenstemmend zijn met alle relevante wetgevingen.

## **(S)** Försäkran om överensstämmelse

Vi **Grundfos** försäkrar under ansvar, att produkterna **TP** och **TPD**, som omfattas av denna försäkran, är i överensstämmelse med Rådets Direktiv om inbördes närmande till EU-medlemsstaternas lagstiftning, avseende

- Maskinell utrustning (98/37/EC).  
Använd standard: EN 809.
- Elektrisk material avsedd för användning inom vissa spänningsgränser (2006/95/EC).  
Använda standarder: MG, MMG, Siemens, Teco: EN 60204-1, EN 60034-1 och EN 60034-5; MMGE: EN 61800-2.
- Elektromagnetisk kompatibilitet (2004/108/EC).  
Använda standarder: MG, MMG, Siemens, Teco: EN 61000-6-2 och EN 61000-6-3; MGE/MMGE: EN 61800-3.

- ATEX 94/9/EC (endast för produkter med ATEX-märkning på typskylten).

Använda standarder: EN 13463-1 och EN 13463-5.  
(Försäkran om överensstämmelse samt monterings- och driftsinstruktion medföljer medlevererad motor.)

### **Pump utan koppling och motor**

Vi **Grundfos** försäkrar under ansvar, att produkterna **TP** och **TPD**, som omfattas av denna försäkran, är i överensstämmelse med Rådets Direktiv om inbördes närmande till EU-medlemsstaternas lagstiftning, avseende

- Maskinell utrustning (98/37/EC) och uppfyller Bilaga II B.  
Använd standard: EN 809.

Före igångkörning av pumpen måste hela applikationen, som pumpen kommer att vara en del av, stämma överens med samtliga relevanta foreskrifter.

## **(DK)** Overensstemmelseserklæring

Vi **Grundfos** erklærer under ansvar at produkterne **TP** og **TPD**, som denne erklæring omhandler, er i overensstemmelse med Rådets direktiver om indbyrdes tilnærmede til EF medlemsstaternes lovgivning om

- Maskiner (98/37/EF).  
Anvendt standard: EN 809.
- Elektrisk materiel bestemt til anvendelse inden for visse spændingsgrænser (2006/95/EF).  
Anvendte standarder: MG, MMG, Siemens, Teco: EN 60204-1, EN 60034-1 og EN 60034-5; MMGE: EN 61800-2.
- Elektromagnetisk kompatibilitet (2004/108/EF).  
Anvendte standarder: MG, MMG, Siemens, Teco: EN 61000-6-2, EN 61000-6-3; MGE/MMGE: EN 61800-3.

- ATEX 94/9/EF (gælder kun for produkter med ATEX-mærkning på typeskiltet).

Anvendte standarder: EN 13463-1 og EN 13463-5.  
(Motorens overensstemmelseserklæring og monterings- og driftsinstruktion er vedlagt.)

### **Pumpe uden kobling og motor:**

Vi **Grundfos** erklærer under ansvar at produkterne **TP** og **TPD**, som denne erklæring omhandler, er i overensstemmelse med Rådets direktiver om indbyrdes tilnærmede til EF medlemsstaternes lovgivning om

- Maskiner (98/37/EF) og opfylder Bilag II B.  
Anvendt standard: EN 809.

Før pumpen tages i brug, skal det komplette maskinlæng hvori den skal inkorporeres, erklæres i overensstemmelse med alle relevante bestemmelser.

## **(FIN)** Vastaavuusvakuutus

Me **Grundfos** vakuutamme yksin vastuullisesti, että tuotteet **TP** ja **TPD**, jota tämä vakuutus koskee, noudattavat direktiivejä jotka käsittelevät EY:n jäsenvaltioiden koneellisia laitteita koskevien lakien yhdenmukaisuutta seur.:

- Koneet (98/37/EY).  
Käytetty standardi: EN 809.
- Määrättyjen jänniterajoitusten puitteissa käytettävät sähköiset laitteet (2006/95/EY).  
Käytetyt standardit: MG, MMG, Siemens, Teco: EN 60204-1, EN 60034-1 ja EN 60034-5; MMGE: EN 61800-2.
- Elektromagneettinen vastaavuus (2004/108/EY).  
Käytetyt standardit: MG, MMG, Siemens, Teco: EN 61000-6-2 ja EN 61000-6-3; MGE/MMGE: EN 61800-3.

- ATEX 94/9/EY (soveltuu vain tuotteisiin, joissa on ATEX-merkintä arvokilvessä).

Käytetyt standardit: EN 13463-1 ja EN 13463-5.  
(Moottorin vaatimustenmukaisuusvakuutus ja käyttöohjeet sisältyvät toimitukseen.)

### **Erillinen pumppu**

Me **Grundfos** vakuutamme yksin vastuullisesti, että tuotteet **TP** ja **TPD**, jota tämä vakuutus koskee, noudattavat direktiivejä jotka käsittelevät EY:n jäsenvaltioiden koneellisia laitteita koskevien lakien yhdenmukaisuutta seur.:

- Konedirektiivin (98/37/EY) ja liitteen II B vaatimusten mukainen.  
Käytetty standardi: EN 809.

Ennen pumpun käyttöönottoa koko järjestelmä, jossa pumpua tullaan käyttämään, on osoitettava kaikkien soveltuvien säädösten mukaiseksi.

## **(PL)** Deklaracja zgodności

My, **Grundfos**, oświadczamy z pełną odpowiedzialnością, że nasze wyroby **TP** oraz **TPD**, których deklaracja niniejsza dotyczy, są zgodne z następującymi wytycznymi Rady d/s ujednolicenia przepisów prawnych krajów człoTPD owskich EG:

- Maszyny (98/37/EG).  
Zastosowana norma: EN 809.
- Wyposażenie elektryczne do stosowania w określonym zakresie napięć (2006/95/EG).  
Zastosowane normy: MG, MMG, Siemens, Teco: EN 60204-1, EN 60034-1 i EN 60034-5; MMGE: EN 61800-2.
- Zgodność elektromagnetyczna (2004/108/EG).  
Zastosowane normy: MG, MMG, Siemens, Teco: EN 61000-6-2 i EN 61000-6-3; MGE/MMGE: EN 61800-3.

- ATEX 94/9/EG (dotyczy tylko wyrobów ze znakiem ATEX na tabliczce znamionowej).

Zastosowane normy: EN 13463-1 i EN 13463-5,  
(deklaracja zgodności oraz instrukcja obsługi i eksploatacji silnika są załączone.)

### **Pompa bez silnika**

My, **Grundfos**, oświadczamy z pełną odpowiedzialnością, że nasze wyroby **TP** oraz **TPD**, których deklaracja niniejsza dotyczy, są zgodne z następującymi wytycznymi Rady d/s ujednolicenia przepisów prawnych krajów człoTPD owskich EG:

- Maszyny (98/37/EG) i Aneks II B.  
Zastosowana norma: EN 809.

Wszystkie urządzenia współpracujące z pompą muszą być zgodne z wszystkimi odpowiednimi wytycznymi.

## **(RU)** Deklaracija o soodvetstvii

Мы, фирма **Grundfos**, со всей ответственностью заявляем, что изделия **TP** и **TPD**, к которым и относится данное свидетельство, отвечают требованиям следующих указаний Совета ЕС об унификации законодательных предписаний стран-членов ЕС:

- Машиностроение (98/37/EC).  
Применяющиеся стандарты: Евростандарт EN 809.
- Электрические машины для эксплуатации в пределах определенного диапазона значений напряжения (2006/95/EC).  
Применяющиеся стандарты: MG, MMG, Siemens, Teco: Евростандарт EN 60204-1, EN 60034-1 и EN 60034-5; MMGE: EN 61800-2.
- Электромагнитная совместимость (2004/108/EC).  
Применяющиеся стандарты: MG, MMG, Siemens, Teco: Евростандарт EN 61000-6-2 и EN 61000-6-3; MGE/MMGE: EN 61800-3.
- ATEX 94/9/EC (действительно только для изделий с маркировкой ATEX на фирменной табличке с техническими данными).  
Применяющиеся стандарты: EN 13463-1 и EN 13463-5. (Заявление о соответствии и руководство по монтажу и эксплуатации электродвигателя прилагаются.)

### **Насос без электродвигателя**

Мы, фирма **Grundfos**, со всей ответственностью заявляем, что изделия **TP** и **TPD**, к которым и относится данное свидетельство, отвечают требованиям следующих указаний Совета ЕС об унификации законодательных предписаний стран-членов ЕС:

- Машиностроение (98/37/EC), соответствует Приложению II B.  
Применяющиеся стандарты: Евростандарт EN 809.

Прежде чем насос будет введен в эксплуатацию, необходимо получить подтверждение, что агрегат в сборе, частью которого будет данный насос, соответствует всем основным требованиям и нормам.

## **(SI)** Izjava o ustreznosti

Ми, **Grundfos**, pod polno odgovornostjo izjavljamo, da so izdelki **TP** in **TPD**, na katere se ta izjava nanaša, v skladu z naslednjimi smernicami Sveta za uskladitev pravnih predpisov držav članic Evropske skupnosti:

- Stroji (98/37/EG).  
Uporabljena norma: EN 809.
- Električna pogonska sredstva za uporabo v določenih napetostnih mejah (2006/95/EG).  
Uporabljeni normi: Standards used: MG, MMG, Siemens, Teco: EN 60204-1, EN 60034-1 in EN 60034-5; MMGE: EN 61800-2.
- Elektromagnetna kompatibilnost (2004/108/EG).  
Uporabljeni normi: MG, MMG, Siemens, Teco: EN 61000-6-2 in EN 61000-6-3; MGE/MMGE: EN 61800-3.
- ATEX 94/9/EG (velja samo za izdelke z oznako ATEX na tipski ploščici).  
Uporabljeni normi: EN 13463-1 in EN 13463-5. (Izjava o ustreznosti ter navodila za montažo in obratovanje motorja sta priložena.)

### **Črpalka brez motorja**

Ми, **Grundfos**, pod polno odgovornostjo izjavljamo, da so izdelki **TP** in **TPD**, na katere se ta izjava nanaša, v skladu z naslednjimi smernicami Sveta za uskladitev pravnih predpisov držav članic Evropske skupnosti:

- Strojna oprema (98/37/EG) in v skladu z aneksom II B.  
Uporabljena norma: EN 809.

Vse postrojenje, katerega del je črpalka, mora biti pred zagonom v skladu z vsemi relevantnimi regulativami.

## **(H)** Konformitási nyilatkozat

Ми, а **Grundfos**, egyedüli felelősséggel kijelentjük, hogy az **TP** és **TPD** termékek, amelyekre jelen nyilatkozat vonatkozik, megfelelnek az Európai Unió tagállamainak jogi irányelveit összehangoló tanács alábbi irányelveinek:

- Gépek (98/37/EK).  
Alkalmazott szabvány: EN 809.
- Meghatározott feszültség határon belül használt elektromos eszközök (2006/95/EK).  
Alkalmazott szabványok: MG, MMG, Siemens, Teco: EN 60204-1, EN 60034-1 és EN 60034-5; MMGE: EN 61800-2.
- Elektromágneses összeférhetőség (2004/108/EK).  
Alkalmazott szabványok: MG, MMG, Siemens, Teco: EN 61000-6-2 és EN 61000-6-3; MGE/MMGE: EN 61800-3.
- ATEX 94/9/EK (csak az ATEX jelzéssel ellátott termékekre vonatkozik).  
Alkalmazott szabványok: EN 13463-1 és EN 13463-5. (A motor kezelési utasítása és megfelelőségi nyilatkozata mellékelve.)

### **Szivattyú motor nélkül**

Ми, а **Grundfos**, egyedüli felelősséggel kijelentjük, hogy az **TP** és **TPD** termékek, amelyekre jelen nyilatkozat vonatkozik, megfelelnek az Európai Unió tagállamainak jogi irányelveit összehangoló tanács alábbi irányelveinek:

- Gépek (98/37/EK) és II B függelék.  
Alkalmazott szabvány: EN 809.

A szivattyú üzembe helyezése előtt a teljes gépegységet, amelybe a szivattyú beépítésre kerül, a vonatkozó előírások szerint minősíteni kell.

## **(HR)** Izjava o usklađenosti

Ми, **Grundfos**, izjavljujemo uz punu odgovornost, da su proizvodi **TP** i **TPD**, na koje se ova izjava odnosi, sukladni smjernicama Savjeta za prilagodbu propisa država-članica EZ:

- Strojevi (98/37/EZ).  
Korištena norma: EN 809.
- Električni pogonski uređaji za korištenje unutar određenih granica napona (2006/95/EZ).  
Korištene norme: MG, MMG, Siemens, Teco: EN 60204-1, EN 60034-1 i EN 60034-5; MMGE: EN 61800-2.
- Elektromagnetska kompatibilnost (2004/108/EZ).  
Korištene norme: MG, MMG, Siemens, Teco: EN 61000-6-2 i EN 61000-6-3; MGE/MMGE: EN 61800-3.
- ATEX 94/9/EZ (vrijedi samo za proizvode s ATEX-znakom na natpisnoj pločici).  
Korištene norme: EN 13463-1 i EN 13463-5. (Deklaracija o usklađenosti te motažne i pogonske upute priloženi su uz motor.)

### **Črpka bez motorja**

Ми, **Grundfos**, izjavljujemo uz punu odgovornost, da su proizvodi **TP** i **TPD**, na koje se ova izjava odnosi, sukladni smjernicama Savjeta za prilagodbu propisa država-članica EZ:

- Strojevi (98/37/EZ) i zadovoljava Annex II B.  
Korištena norma: EN 809.

Prije puštanja u pogon crpke, kompletan uređaj u koji je crpka ugrađena mora biti u skladu s odgovarajućim propisima.

## **SE** Izjava o konformitetu

Ми, **Grundfos**, изјављујемо под потпуном одговорношћу да су производи **TP** и **TPD** на које се односи ова изјава у сагласности са смерницима и упутствима Савета за усаглашавање правних прописа чланца Европске уније:

- Машина (98/37/EG).  
Коришћен стандард: EN 809.
- Електрична опрема развијена за коришћење унутар одређених напонских граница (2006/95/EG).  
Коришћени стандарди: MG, MMG, Siemens, Teco: EN 60204-1, EN 60034-1 и EN 60034-5; MMGE: EN 61800-2.
- Електромагнетна усаглашеност (2004/108/EG).  
Коришћени стандарди: MG, MMG, Siemens, Teco: EN 61000-6-2 и EN 61000-6-3; MGE/MMGE: EN 61800-3.
- ATEX 94/9/EG (односи се само на производе са натписом ATEX на натписној плочици).  
Коришћени стандарди: EN 13463-1 и EN 13463-5, (декларација конформитета и упутства за инсталацију и рад мотора су приложени.)

### **Пумпа без мотора**

Ми, **Grundfos**, изјављујемо под потпуном одговорношћу да су производи **TP** и **TPD** на које се односи ова изјава у сагласности са смерницима и упутствима Савета за усаглашавање правних прописа чланца Европске уније:

- Машина: EN (98/37/EG) и у складу је са Anexom II B.  
Коришћен стандард: EN 809.

Пре него што се пумпа пусти у рад комплетна машинерија у коју је пумпа инкорпорисана мора бити у складу са локалним битним регулативама.

## **BG** Декларација за съответствие

Ние, фирма **Grundfos** заявяваме с пълна отговорност, че продуктите **TP** и **TPD**, за които се отнася настоящата декларация, отговарят на следните указания на Съвета за уеднаквяване на правните разпоредби на държавите членки на ЕО:

- Машини (98/37/EO).  
Приложена норма: EN 809.
- Електрически машини и съоръжения за употреба в рамките на определени граници на напрежение на електрическия ток (2006/95/EO).  
Приложени норми: MG, MMG, Siemens, Teco: EN 60204-1, EN 60034-1 и EN 60034-5; MMGE: EN 61800-2.
- Електромагнетична поносимост (2004/108/EO).  
Приложени норми: MG, MMG, Siemens, Teco: EN 61000-6-2 и EN 61000-6-3; MGE/MMGE: EN 61800-3.
- ATEX 94/9/EO (отнася се само за продукти със символа ATEX върху табелата с данни).  
Приложени норми: EN 13463-1 и EN 13463-5.  
(Приложени са също и Декларацията за съответствие и инструкциите за монтаж и експлоатация на двигателя.)

### **Помпа със свободен вал**

Ние, фирма **Grundfos** заявяваме с пълна отговорност, че продуктите **TP** и **TPD**, за които се отнася настоящата декларация, отговарят на следните указания на Съвета за уеднаквяване на правните разпоредби на държавите членки на ЕО:

- Машини (98/37/EO) и Анекс II B.  
Приложена норма: EN 809.

Преди да се въведе в експлоатация помпата, трябва да се декларира съответствието на цялото съоръжение, в което се вгражда тази помпа, към съответните актуални наредби и стандарти.

## **RO** Declarație de conformitate

Noi, **Grundfos**, declarăm asumându-ne întreaga responsabilitate că produsele **TP**, **TPD** la care se referă această declarație sunt în conformitate cu Directivile Consiliului în ceea ce privește alinierea legislațiilor Statelor Membre ale CE, referitoare la:

- Utilaje (98/37/CE).  
Standard aplicat: EN 809.
- Echipamente electrice destinate utilizării între limite exacte de tensiune (2006/95/CE).  
Standarde aplicate: MG, MMG, Siemens, Teco: EN 60204-1, EN 60034-1 și EN 60034-5; MMGE: EN 61800-2.
- Compatibilitate electromagnetă (2004/108/CE).  
Standarde aplicate: MG, MMG, Siemens, Teco: EN 61000-6-2 și EN 61000-6-3; MGE/MMGE: EN 61800-3.
- ATEX 94/9/CE (se aplică numai la produsele cu marca ATEX pe plăcuța de înmatriculare).  
Standarde aplicate: EN 13463-1 și EN 13463-5.  
(Declarația de conformitate și instrucțiunile de instalare și operare ale motorului sunt incluse.)

### **Pompă fără motor**

Noi, **Grundfos**, declarăm asumându-ne întreaga responsabilitate că produsele **TP**, **TPD** la care se referă această declarație sunt în conformitate cu Directivile Consiliului în ceea ce privește alinierea legislațiilor Statelor Membre ale CE, referitoare la:

- Utilaje (98/37/CE) și conform Anexei II B.  
Standard aplicat: EN 809.

Înainte de pornirea pompei, utilajul complet în care este încorporată pompa trebuie să fie în conformitate cu toate reglementările care îl se aplică.

## **CZ** Prohlášení o shodě

My firma **Grundfos** prohlašujeme na svou plnou odpovědnost, že výrobky **TP** a **TPD** (na něž se toto prohlášení vztahuje, jsou v souladu s ustanoveními směrnice Rady pro sblížení právních předpisů členských států Evropského společenství v oblastech:

- Strojírěnství (98/37/EG).  
Použitá norma: EN 809.
- Provozování spotřebičů v toleranci napětí (2006/95/EG).  
Použitá norma: MG, MMG, Siemens, Teco: EN 60204-1, EN 60034-1 a EN 60034-5; MMGE: EN 61800-2.
- Elektromagnetická kompatibilita (2004/108/EG).  
Použitá norma: MG, MMG, Siemens, Teco: EN 61000-6-2 a EN 61000-6-3; MGE/MMGE: EN 61800-3.
- ATEX 94/9/EG (týká se pouze výrobků nesoucích na typovém štítku značku ATEX).  
Použitá norma: EN 13463-1 a EN 13463-5, (prohlášení o konformitě a instalační a provozní předpisy motoru jsou přiloženy.)

### **Čerpadlo bez motoru**

My firma **Grundfos** prohlašujeme na svou plnou odpovědnost, že výrobky **TP** a **TPD** (na něž se toto prohlášení vztahuje, jsou v souladu s ustanoveními směrnice Rady pro sblížení právních předpisů členských států Evropského společenství v oblastech:

- Strojní zařízení (98/37/EG) a vyhovující příloze II B.  
Použitá norma: EN 809.

Před uvedením čerpadla do provozu, musí být kompletní strojní zařízení, jehož součástí čerpadlo je, deklarováno ve shodě se všemi příslušnými předpisy.

## **(SK) Prehlásenie o konformite**

My firma **Grundfos**, na svoju plnú zodpovednosť prehlasujeme, že výrobky **TP, TPD**, na ktoré sa toto prehlásenie vzťahuje, sú v súlade s nasledovnými smernicami Rady pro zblíženie právnych predpisov členských zemí Európskej únie:

- Stroje (98/37/EG),  
Použitá norma: EN 809.
- Elektrické prevádzkové prostriedky, použité v určitom napätovom rozsahu (2006/95/EG),  
Použitá normy: MG, MMG, Siemens, Teco: EN 60204-1, EN 60034-1 a EN 60034-5; MMGE: EN 61800-2.
- Elektromagnetická kompatibilita (2004/108/EG),  
Použitá normy: MG, MMG, Siemens, Teco: EN 61000-6-2 a EN 61000-6-3; MGE/MMGE: EN 61800-3.
- ATEX 94/9/EG (týka sa iba výrobkov nesúcich na typovom štítku značku ATEX).  
Použitá normy: EN 13463-1 a EN 13463-5.  
(Prehlásenie o konformite a montážny a prevádzkový návod motora sú priložené.)

### **Čerpadlo bez motora**

My firma **Grundfos**, na svoju plnú zodpovednosť prehlasujeme, že výrobky **TP, TPD**, na ktoré sa toto prehlásenie vzťahuje, sú v súlade s nasledovnými smernicami Rady pro zblíženie právnych predpisov členských zemí Európskej únie:

- Zariadenia (98/37/EG) a vyhovujúce prílohe II B.  
Použitá norma: EN 809.

Pred uvedením čerpadla do prevádzky, musí byť kompletne zariadenie - ktorého súčasťou je aj čerpadlo, deklarované v zhode so všetkými príslušnými predpismi.

## **(EE) Vastavuse deklaratsioon**

Meie **Grundfos** deklareerime enda ainuvastutusel, et toode **TP** ja **TPD**, mille kohta käesolev juhend käib, on vastavuses EL nõukogu Direktiividega EMÜ liikmesriikide seaduste ühitamise kohta, mis käsitlevad:

- Masinad (98/37/EC).  
Kasutatud standardit: EN 809.
- Madalapinge-elektriseadmed (2006/95/EC).  
Kasutatud standardit: MG, MMG, Siemens, Teco: EN 60204-1, EN 60034-1 ja EN 60034-5; MMGE: EN 61800-2.
- Elektrimagnetilist ühilduvust (2004/108/EC).  
Kasutatud standardit: MG, MMG, Siemens, Teco: EN 61000-6-2 ja EN 61000-6-3; MGE/MMGE: EN 61800-3.
- ATEX 94/9/EC (ainult toodete korral, mille sildikul on ATEX tähistus).  
Kasutatud standardit: EN 13463-1 ja EN 13463-5.  
(Mootori vastavuse deklaratsioon ning paigaldus- ja kasutusjuhend on lisatud.)

### **Ilma mootorita pump**

Meie **Grundfos** deklareerime enda ainuvastutusel, et toode **TP** ja **TPD**, mille kohta käesolev juhend käib, on vastavuses EL nõukogu Direktiividega EMÜ liikmesriikide seaduste ühitamise kohta, mis käsitlevad:

- Masinad (98/37/EC) ja rahuldab Osa II B nõudeid.  
Kasutatud standardit: EN 809.

Enne pumba töösse võtmist peab kogu seadmestik, millesse pump kuulub, olema heakskiidetud vastavalt asjakohastele eeskirjadele.

Bjerringbro, 4th March 2008



Svend Aage Kaas  
Technical Director



# TP, TPD

Installation and operating instructions	10	GB
Montage- und Betriebsanleitung	21	D
Notice d'installation et d'entretien	33	F
Istruzioni di installazione e funzionamento	44	I
Instrucciones de instalación y funcionamiento	55	E
Instruções de instalação e funcionamento	66	P
Οδηγίες εγκατάστασης και λειτουργίας	77	GR
Installatie- en bedieningsinstructies	88	NL
Monterings- och driftsinstruktion	99	S
Asennus- ja käyttöohjeet	110	FIN
Monterings- og driftsinstruktion	121	DK
Instrukcja montażu i eksploatacji	132	PL
Руководство по монтажу и эксплуатации	144	RU
Szerelési és üzemeltetési utasítás	157	H
Navodila za montažo in obratovanje	168	SI
Montažne i pogonske upute	179	HR
Uputstvo za montažu i upotrebu	190	SER
Instrucțiuni de instalare și utilizare	201	RO
Упътване за монтаж и експлоатация	212	BG
Montážní a provozní návod	224	CZ
Návod na montáž a prevádzku	235	SK
Paigaldus- ja kasutusjuhend	247	EE

# CONTENTS

	Page
<b>1. Symbols used in this document</b>	<b>10</b>
<b>2. General</b>	<b>10</b>
<b>3. Delivery and handling</b>	<b>11</b>
3.1 Delivery	11
3.2 Handling	11
<b>4. Applications</b>	<b>11</b>
4.1 Pumped liquids	12
<b>5. Installation</b>	<b>12</b>
5.1 Pipework	13
5.2 Elimination of noise and vibrations	13
5.3 Foundation	13
5.4 Terminal box positions	14
5.5 Base plate	14
5.6 Frost protection	14
<b>6. Electrical connection</b>	<b>14</b>
6.1 Frequency converter operation	15
<b>7. Start-up</b>	<b>15</b>
7.1 Priming	15
7.2 Checking the direction of rotation	16
7.3 Starting	16
7.4 Frequency of starts and stops	16
<b>8. Maintenance and service</b>	<b>16</b>
8.1 Pump	16
8.2 Motor	16
8.3 Service	17
8.4 Shaft adjustment	17
8.5 Blanking flanges	17
<b>9. Technical data</b>	<b>18</b>
9.1 Ambient temperature	18
9.2 Liquid temperature	18
9.3 Operating pressure/test pressure	18
9.4 Inlet pressure	18
9.5 Enclosure class	18
9.6 Electrical data	18
9.7 Sound pressure level	18
9.8 Environment	18
<b>10. Fault finding chart</b>	<b>19</b>
<b>11. Disposal</b>	<b>20</b>

## **Warning**



**Prior to installation, read these installation and operating instructions. Installation and operation must comply with local regulations and accepted codes of good practice.**

## 1. Symbols used in this document



### **Warning**

**If these safety instructions are not observed, it may result in personal injury!**



**If these safety instructions are not observed, it may result in malfunction or damage to the equipment!**



**Notes or instructions that make the job easier and ensure safe operation.**

## 2. General

These instructions apply to the pump types TP and TPD fitted with Grundfos motors. If the pump is fitted with another motor make, please note that the motor data may differ from the data stated in these instructions.

### 3. Delivery and handling

#### 3.1 Delivery

The pump is delivered from the factory in a carton with a wooden bottom, which is specially designed for transport by fork-lift truck or a similar vehicle.

#### 3.2 Handling

##### Warning

The lifting eyes fitted to large pump motors can be used for lifting the pump head (motor, motor stool and impeller). The lifting eyes must not be used for lifting the entire pump.



**TPD:** The centrally positioned thread of the pump housing must not be used for lifting purposes as the thread is placed below the centre of gravity of the pump.

Pumps without lifting eyes should be lifted by means of nylon straps. See figs 1 and 2.

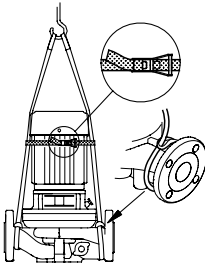

Fig. 1 TP

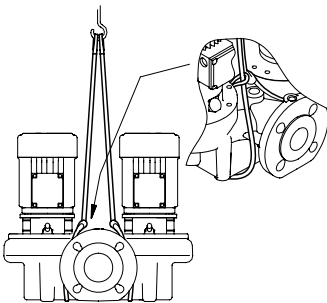

Fig. 2 TPD

Pumps with lifting eyes should be lifted by means of nylon straps and shackles. See figs 3 and 4.

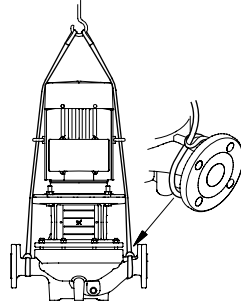

Fig. 3 TP

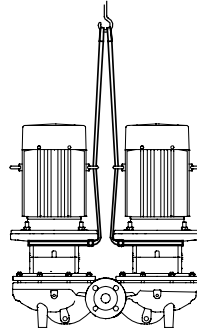

Fig. 4 TPD

### 4. Applications

The pumps are designed to circulate hot or cold water in for instance

- heating systems
- district heating plants
- central heating systems for blocks of flats
- air-conditioning systems
- cooling systems

in residential, institutional and industrial applications.

In addition, the pump range is used for liquid transfer and water supply in for instance

- washing systems
- domestic hot water systems
- industrial systems in general.

To ensure optimum operation, the dimensioning range of the system must fall within the performance range of the pump.

### 4.1 Pumped liquids

Thin, clean, non-aggressive and non-explosive liquids, not containing solid particles or fibres that may attack the pump mechanically or chemically.

Examples:

- central heating system water (the water should meet the requirements of accepted standards on water quality in heating systems)
- cooling liquids
- domestic hot water
- industrial liquids
- softened water.

The pumping of liquids with a density and/or kinematic viscosity higher than that of water will cause

- a considerable pressure drop
- a drop in hydraulic performance
- a rise in power consumption.

In such cases, the pump should be fitted with a bigger motor. If in doubt, contact Grundfos.

The EPDM O-rings fitted as standard are primarily suitable for water.

If the water contains mineral/synthetic oils or chemicals or if other liquids than water are pumped, the O-rings should be chosen accordingly.

### 5. Installation

**Warning**



**When pumping hot liquids, care should be taken to ensure that persons cannot accidentally come into contact with hot surfaces.**

The pump must be sited in a dry well ventilated, but frost-free position.

When installing pumps with oval bolt holes in the pump flange (PN 6/10), washers must be used as shown in fig. 5.

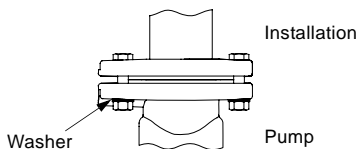

**Fig. 5** Use of washers for oval bolt holes

Arrows on the pump housing show the direction of flow of liquid through the pump.

Pumps with motors smaller than 11 kW can be installed in horizontal or vertical pipework.

Pumps with motors of 11 kW and up may only be installed in horizontal pipework with the motor in vertical position.

**Caution** *The motor must never fall below the horizontal plane.*

For inspection and motor/pump head removal, the following clearance is required above the motor:

- 300 mm for motors up to and including 4.0 kW.
- 1 metre for motors of 5.5 kW and up.

See fig. 6.

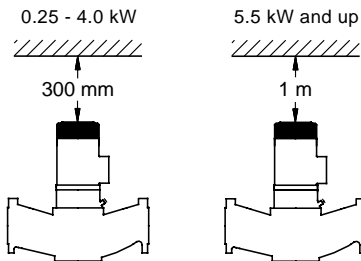

**Fig. 6** Required clearance above the motor

Twin-head pumps installed in horizontal pipes must be fitted with an automatic air vent in the upper part of the pump housing. See fig. 7.

The automatic air vent is not supplied with the pump.

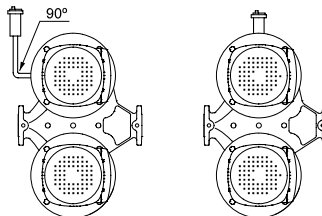

**Fig. 7** Automatic air vent

If the liquid temperature falls below the ambient temperature, condensation may form in the motor during inactivity. In this case, it must be ensured that the drain hole in the motor flange is open and points downwards. See fig. 8.

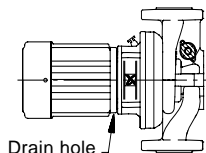

**Fig. 8** Drain hole in motor flange

If twin-head pumps are used for pumping liquids with a temperature below 0 °C/32 °F, condensed water may freeze and cause the coupling to get stuck. The problem can be remedied by installing heating elements. Whenever possible (pumps with motors smaller than 11 kW), the pump should be installed with the motor shaft in horizontal position. See fig. 7.

**Caution** *The technical data in section 9. must be observed.*

### 5.1 Pipework

Isolating valves should be fitted either side of the pump to avoid draining the system if the pump needs to be cleaned or repaired.

The pump is suitable for pipeline mounting, provided that the pipework is adequately supported either side of the pump. TP 25-50, 25-90, 32-50, 32-90, 40-50 and 40-90 are designed for pipeline mounting only.

When installing the pipes, it must be ensured that the pump housing is not stressed by the pipework.

The suction and discharge pipes must be of an adequate size, taking the pump inlet pressure into account.

To avoid sediment build-up, do not fit the pump at the lowest point of the system.

Install the pipes so that air locks are avoided, especially on the suction side of the pump. See fig. 9.

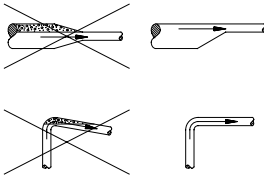

**Fig. 9** Correct pipework on the suction side of the pump

**Caution**

***The pump is not allowed to run against a closed discharge valve as this will cause an increase in temperature/formation of steam in the pump which may cause damage to the pump.***

If there is any danger of the pump running against a closed discharge valve, a minimum liquid flow through the pump should be ensured by connecting a bypass/a drain to the discharge pipe. The drain can for instance be connected to a tank. A minimum flow rate equal to 10 % of the flow rate at maximum efficiency is needed at all times.

Flow rate and head at maximum efficiency are stated on the pump nameplate.

### 5.2 Elimination of noise and vibrations

In order to achieve optimum operation and minimum noise and vibration, consider vibration dampening of the pump. Generally, always consider this for pumps with motors of 11 kW and up, but for motors of 90 kW and up vibration dampening should be considered as mandatory. Smaller motor sizes, however, may also cause undesirable noise and vibration.

Noise and vibration are generated by the revolutions of the motor and pump and by the flow in pipes and fittings. The effect on the environment is subjective and depends on correct installation and the state of the remaining system.

Elimination of noise and vibrations is best achieved by means of a concrete foundation, vibration dampers and expansion joints.

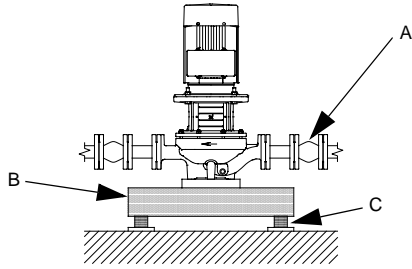

**Fig. 10** Foundation for TP pump

- A: Expansion joint
- B: Concrete pedestal
- C: Vibration damper

### 5.3 Foundation

Grundfos recommends to install the pump on a concrete foundation which is heavy enough to provide permanent and rigid support to the entire pump. The foundation must be capable of absorbing any vibration, normal strain or shock. As a rule of thumb, the weight of the concrete foundation should be 1.5 times the weight of the pump. Place the pump on the foundation and fasten it. See fig. 10.

#### 5.3.1 Recommended concrete foundations for TP(D) Series 300 pumps

For TP Series 300 pumps with weights of 150 kg or more, it is recommended to mount the pump on a concrete foundation with the dimensions stated in the table below. The same recommendation applies for TPD Series 300 pumps with weights of 300 kg or more.

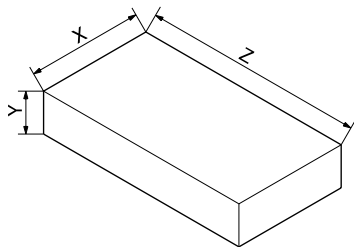

TM03 9190 3607

Fig. 11 Foundation for TP(D) Series 300 pumps

Concrete foundation dimensions			
Pump weight [kg]	Y (height) [mm]	Z (length) [mm]	X (width) [mm]
150	280	565	565
200	310	620	620
250	330	670	670
300	360	710	710
350	375	750	750
400	390	780	780
450	410	810	810
500	420	840	840
550	440	870	870
600	450	900	900
650	460	920	920
700	470	940	940
750	480	970	970
800	490	990	990
850	500	1010	1010
900	510	1030	1030
950	520	1050	1050
1000	530	1060	1060
1050	540	1080	1080
1100	550	1100	1100
1150	560	1100	1100
1200	560	1130	1130
1250	570	1150	1150
1300	580	1160	1160
1350	590	1180	1180
1400	600	1190	1190
1450	600	1200	1200
1500	610	1220	1220
1550	620	1230	1230
1600	620	1250	1250
1650	630	1250	1250
1700	635	1270	1270

## 5.4 Terminal box positions



### Warning

**Before starting work on the pump, make sure that the electricity supply has been switched off and that it cannot be accidentally switched on.**

The terminal box can be turned to any of four positions, in 90° steps.

Change the terminal box position as follows:

1. If necessary, remove the coupling guards using a screwdriver. Do not remove the coupling.
2. Remove the screws securing the motor to the pump.
3. Turn the motor to the required position.
4. Replace and tighten the screws.
5. Replace the coupling guards.

## 5.5 Base plate

Single-head pumps (except TP 25-50, 25-90, 32-50, 32-90, 40-50 and 40-90) have two tapped holes in the bottom of the pump housing which can be used for fitting a Grundfos base plate to the pump.

The base plate is available as an optional extra.

Twin-head pumps have four tapped holes in the bottom of the pump housing. For some twin-head pumps, a base plate consisting of two halves is available.

Base plates with dimensions are shown on page 270.

## 5.6 Frost protection

Pumps which are not being used during periods of frost should be drained to avoid damage.

## 6. Electrical connection

The electrical connection should be carried out in accordance with local regulations.



### Warning

**Before removing the terminal box cover and before any removal/dismantling of the pump, make sure that the electricity supply has been switched off.**

**The pump must be connected to an external mains switch with a minimum contact gap of 3 mm in all poles.**

The operating voltage and frequency are marked on the pump nameplate. Make sure that the motor is suitable for the electricity supply on which it will be used.

Single-phase standard motors incorporate a thermal switch and require no additional motor protection.

Three-phase motors must be connected to a motor starter.

Motors of 3 kW and up incorporate thermistors (PTC). The thermistors are designed according to DIN 44082.

The electrical connection should be carried out as shown in the diagram inside the terminal box cover.

The motors of twin-head pumps are to be connected separately.

**Caution** *Do not start the pump until it has been filled with liquid and vented.*

## 6.1 Frequency converter operation

*Motors types MEZ 63, MG 71 and MG 80 for supply voltages up to and including 440 V (see motor nameplate) must be protected against voltage peaks higher than 650 V between the supply terminals.*

**Caution**

### Grundfos motors:

All three-phase Grundfos motors from frame size 90 and up can be connected to a frequency converter. The connection of a frequency converter will often have the effect that the motor insulation system is loaded more and that the motor will be more noisy than during normal operation. In addition, large motors are loaded by bearing currents caused by the frequency converter.

In the case of frequency converter operation, the following should be considered:

- In 2-, 4- and 6-pole motors of 75 kW and up, one of the motor bearings should be electrically isolated to prevent damaging currents from passing through the motor bearings.
- In the case of noise-critical applications, the motor noise can be reduced by fitting a dU/dt filter between the motor and the frequency converter. In particularly noise-critical applications, it is recommended to fit a sinusoidal filter.
- The length of the cable between motor and frequency converter affects the motor load. It should therefore be checked that the cable length meets the specifications laid down by the frequency converter supplier.
- For supply voltages between 500 and 690 V, either a dU/dt filter should be fitted to reduce voltage peaks or a motor with reinforced insulation should be used.
- For supply voltages of 690 V, a motor with reinforced insulation should be used and a dU/dt filter should be fitted.

### 6.1.1 Other motor makes than Grundfos

Contact Grundfos or the motor manufacturer.

## 7. Start-up

*Do not start the pump until it has been filled with liquid and vented. To ensure correct venting, the vent screw should point upwards.*

**Caution**

### 7.1 Priming

Closed systems or open systems where the liquid level is above the pump inlet:

1. Close the discharge isolating valve and loosen the air vent screw in the motor stool. See fig. 12.

#### Warning

*Pay attention to the direction of the vent hole and take care to ensure that the escaping water does not cause injury to persons or damage to the motor or other components. In hot-water installations, special attention should be paid to the risk of injury caused by scalding hot water.*



2. Slowly open the isolating valve in the suction pipe until a steady stream of liquid runs out of the vent hole.
3. Tighten the air vent screw and completely open the isolating valve(s).

#### Open systems where the liquid level is below the pump inlet:

The suction pipe and the pump must be filled with liquid and vented before the pump is started.

1. Close the discharge isolating valve and open the isolating valve in the suction pipe.
2. Loosen the air vent screw. See fig. 12.
3. Remove the plug from one of the pump flanges, depending on the pump location.
4. Pour liquid through the priming port until the suction pipe and the pump are filled with liquid.
5. Replace the plug and tighten securely.
6. Tighten the air vent screw.

The suction pipe can to some extent be filled with liquid and vented before it is connected to the pump. A priming device can also be installed before the pump.

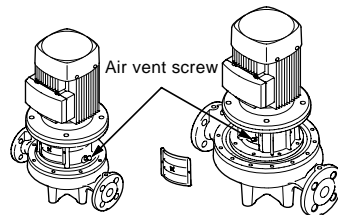

Fig. 12 Position of air vent screw

## 7.2 Checking the direction of rotation

Do not start the pump to check the direction of rotation until it has been filled with liquid.

GB

Note

**The direction of rotation should not be checked with the motor alone, as an adjustment of the shaft position is required when the coupling has been removed.**

The correct direction of rotation is shown by arrows on the motor fan cover or on the pump housing.

## 7.3 Starting

1. Before starting the pump, completely open the isolating valve on the suction side of the pump and leave the discharge isolating valve almost closed.
2. Start the pump.
3. Vent the pump during starting by loosening the air vent screw in the motor stool until a steady stream of liquid runs out of the vent hole. See fig. 12.

### Warning

**Pay attention to the direction of the vent hole and take care to ensure that the escaping water does not cause injury to persons or damage to the motor or other components.**

**In hot-water installations, special attention should be paid to the risk of injury caused by scalding hot water.**

4. When the piping system has been filled with liquid, slowly open the discharge isolating valve until it is completely open.



## 7.4 Frequency of starts and stops

Frame size	Maximum number of starts per hour		
	Number of poles		
	2	4	6
56-71	100	250	350
80-100	60	140	160
112-132	30	60	80
160-180	15	30	50
200-225	8	15	30
250-315	4	8	12

- On twin-head pumps, the duty and standby pumps should be alternated on a regular basis, i.e. once a week, to ensure an even distribution of the operating hours on both pumps. Pump change can be effected either manually or automatically by installing a suitable pump controller.
- If twin-head pumps are used for pumping domestic hot water, the duty and standby pumps should be alternated on a regular basis, i.e. once a day, to avoid blocking of the standby pump due to deposits (calcareous deposits, etc.). Automatic pump change is recommended.

## 8. Maintenance and service

### Warning

**Before starting work on the pump, make sure that the electricity supply has been switched off and that it cannot be accidentally switched on.**



### 8.1 Pump

The pump is maintenance-free.

If the pump is to be drained for a long period of inactivity, inject a few drops of silicone oil on the shaft between the motor stool and the coupling. This will prevent the shaft seal faces from sticking.

### 8.2 Motor

The motor should be checked at regular intervals. It is important to keep the motor clean in order to ensure adequate ventilation. If the pump is installed in a dusty environment, the pump must be cleaned and checked regularly.

### Lubrication:

The bearings of motors up to 11 kW are greased for life and require no lubrication.

The bearings of motors of 11 kW and up must be greased in accordance with the indications on the motor nameplate.

The motor should be lubricated with a lithium-based grease meeting the following specifications:

- NLGI grade 2 or 3.
- Viscosity of basic oil: 70 to 150 cSt at 40 °C (~ +104 °F).
- Temperature range: -30 °C (~ -22 °F) to 140 °C (~ +284 °F) during continuous operation.

### 8.3 Service



#### Warning

**If the pump has been used for a liquid which is injurious to health or toxic, the pump will be classified as contaminated.**

If Grundfos is requested to service the pump, Grundfos must be contacted with details about the pumped liquid, etc. before the pump is returned for service. Otherwise Grundfos can refuse to accept the pump for service.

Possible costs of returning the pump are paid by the customer.

### 8.4 Shaft adjustment

If the motor has been removed during installation or for repair of the pump, the pump shaft must be adjusted after the motor has been replaced.

#### 8.4.1 Pumps with two-part coupling

##### Pumps Series 100 and 200

Make sure that the shaft pin is fitted in the pump shaft.

Adjust the pump shaft as follows:

1. Remove the coupling guards using a screwdriver.
2. Fit the hexagon socket head screws in the coupling and leave loose.
3. Raise the coupling and the pump shaft as far as possible (towards the motor) with a screwdriver or a similar tool so that the pump and motor shafts touch each other. See fig. 13.

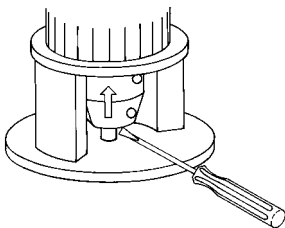

Fig. 13 Raising the coupling and the pump shaft

TM00 6415 3695

4. Tighten the hexagon socket head screws in the coupling to 5 Nm (0.5 kpm).
5. Check that the gaps either side of the coupling halves are equal.
6. Tighten the screws two and two (one side at a time) to the torque stated below. See fig. 14.

Hexagon socket head screw	Torque
M6 x 20	13 Nm (1.3 kpm)
M8 x 25	31 Nm (3.1 kpm)

7. Fit the coupling guards.

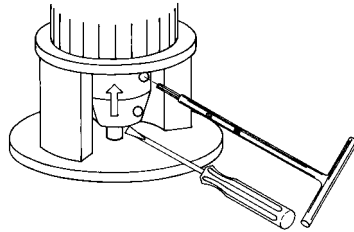

Fig. 14 Tightening the screws

TM00 6416 3695

#### 8.4.2 Pumps with integral shaft/coupling

For pumps with integral shaft/coupling, it is advisable *not* to remove the motor. If the motor has been removed, it is necessary to remove the motor stool in order to refit the motor correctly. Otherwise the shaft seal may be damaged.

### 8.5 Blanking flanges

For twin-head pumps, a blanking flange with a pump housing gasket is available. See fig. 15.

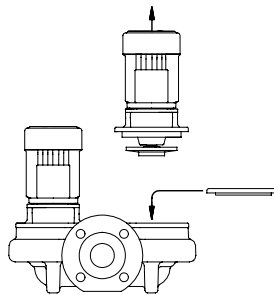

Fig. 15 Fitting the blanking flange

If one pump requires service, the blanking flange is fitted to allow the other pump to continue operating.

TM00 6360 3495

## 9. Technical data

### 9.1 Ambient temperature

Maximum +55 °C (~ +131 °F).

### 9.2 Liquid temperature

–25 °C (~ –13 °F) up to +140 °C (~ +288 °F).

The maximum liquid temperature depends on the mechanical shaft seal type and the pump type.

Depending on the cast-iron version and the pump application, the maximum liquid temperature may be limited by local regulations and laws.

The maximum liquid temperature is marked on the pump nameplate.

***If the pump is operating with liquids at high temperatures, the life of the shaft seal may be reduced. It may be necessary to replace the shaft seal more often.***

Note

### 9.3 Operating pressure/test pressure

The pressure test has been made with water containing anti-corrosive additives at a temperature of +20 °C (~ +68 °F).

Pressure stage	Operating pressure		Test pressure	
	bar	MPa	bar	MPa
PN 6	6	0.6	10	1.0
PN 6/PN 10	10	1.0	15	1.5
PN 16	16	1.6	24	2.4

### 9.4 Inlet pressure

To ensure optimum and quiet pump operation, the inlet pressure (system pressure) must be adjusted correctly. See table on page 258.

For the calculation of specific inlet pressures, contact the local Grundfos company or see the data booklet for TP(D)/TPE(D), if at hand.

### 9.5 Enclosure class

Closed drain hole in motor: IP 55.

Open drain hole in motor: IP 44.

(Drain hole, see fig. 8.)

### 9.6 Electrical data

See motor nameplate.

## 9.7 Sound pressure level

### Pumps with single-phase motors:

The sound pressure level of the pump is lower than 70 dB(A).

### Pumps with three-phase motors:

See table on page 269.

## 9.8 Environment

Non-aggressive and non-explosive atmosphere.

Relative air humidity: Maximum 95 %.

## 10. Fault finding chart



### Warning

**Before removing the terminal box cover and before removal/dismantling of the pump, make sure that the electricity supply has been switched off and that it cannot be accidentally switched on.**

GB

Fault	Cause
1. Motor does not run when started.	<ul style="list-style-type: none"> <li>a) Supply failure.</li> <li>b) Fuses blown.</li> <li>c) Motor starter overload has tripped out.</li> <li>d) Main contacts in motor starter are not making contact or the coil is faulty.</li> <li>e) Control circuit fuses are defective.</li> <li>f) Motor is defective.</li> </ul>
2. Motor starter overload trips out immediately when supply is switched on.	<ul style="list-style-type: none"> <li>a) Supply failure.</li> <li>b) Contacts in motor starter overload are faulty.</li> <li>c) Cable connection is loose or faulty.</li> <li>d) Motor winding is defective.</li> <li>e) Pump mechanically blocked.</li> <li>f) Overload setting too low.</li> </ul>
3. Motor starter overload trips out occasionally.	<ul style="list-style-type: none"> <li>a) Overload setting too low.</li> <li>b) Supply voltage periodically too low or too high.</li> <li>c) Differential pressure across pump too low.</li> </ul>
4. Motor starter has not tripped out but the pump does not run.	<ul style="list-style-type: none"> <li>a) Check the electricity supply.</li> <li>b) Check fuses.</li> <li>c) Check main contacts in motor starter and coil.</li> <li>d) Check the control circuit.</li> </ul>
5. Pump capacity not constant.	<ul style="list-style-type: none"> <li>a) Pump inlet pressure is too low.</li> <li>b) Suction pipe/pump partly blocked by impurities.</li> <li>c) Pump draws in air.</li> </ul>
6. Pump runs but gives no water.	<ul style="list-style-type: none"> <li>a) Suction pipe/pump blocked by impurities.</li> <li>b) Foot or non-return valve blocked in closed position.</li> <li>c) Leakage in suction pipe.</li> <li>d) Air in suction pipe or pump.</li> <li>e) Motor rotates in the wrong direction.</li> </ul>
7. Pump runs backwards when switched off.*	<ul style="list-style-type: none"> <li>a) Leakage in suction pipe.</li> <li>b) Foot or non-return valve defective.</li> <li>c) Foot or non-return valve blocked in open or partly open position.</li> </ul>
8. Leakage in shaft seal.	<ul style="list-style-type: none"> <li>a) Pump shaft position is incorrect.</li> <li>b) Shaft seal is defective.</li> </ul>
9. Noise.	<ul style="list-style-type: none"> <li>a) Pump is cavitating.</li> <li>b) Pump does not rotate freely (frictional resistance) because of incorrect pump shaft position.</li> <li>c) Frequency converter operation: - See 6.1 <i>Frequency converter operation</i>.</li> <li>d) Resonance in the installation.</li> <li>e) Foreign bodies in the pump.</li> </ul>
10. Pump runs constantly (applies only to pumps with automatic start/stop).	<ul style="list-style-type: none"> <li>a) Stop pressure is too high in relation to the required quantity of water.</li> <li>b) The water consumption is larger than anticipated.</li> <li>c) Leakage in discharge pipe.</li> <li>d) The direction of rotation of the pump is incorrect.</li> <li>e) Pipes, valves or strainer blocked by impurities.</li> <li>f) Pump controller, if used, is defective.</li> </ul>
11. Period of operation is too long (applies only to pumps with automatic start/stop).	<ul style="list-style-type: none"> <li>a) Stop pressure is too high in relation to the required quantity of water.</li> <li>b) Pipes, valves or strainer blocked by impurities.</li> <li>c) Pump partly blocked or furred up.</li> <li>d) The water consumption is larger than anticipated.</li> <li>e) Leakage in discharge pipe.</li> </ul>

\* In twin-head pump installations, the standby pump will often rotate slowly.

## 11. Disposal

This product or parts of it must be disposed of in an environmentally sound way:

1. Use the public or private waste collection service.
2. If this is not possible, contact the nearest Grundfos company or service workshop.

GB

- GB:** Inlet pressure stated in bar relative pressure (pressure gauge value measured on the suction side of the pump)
- D:** Zulaufdruck in bar Relativdruck (Manometerdruck auf der Saugseite der Pumpe gemessen)
- F:** Pression d'entrée indiquée en bar (valeur mesurée à l'aide d'un manomètre placé sur le côté aspiration de la pompe)
- I:** Pressione di aspirazione indicata in bar (valore misurato con un manometro posto sul lato aspirazione della pompa)
- E:** Presión de aspiración indicada en bar como presión relativa (valor del manómetro medido en la aspiración de la bomba)
- P:** Pressão de entrada com a pressão relativa apresentada em bar (ponto de medida na parte de aspiração da bomba)
- GR:** Πίεση αναρρόφησης σε bar σχετικής πίεσης (μετρούμενη τιμή πίεσης στην πλευρά αναρρόφησης της αντλίας)
- NL:** Inlaatdruk weergegeven in bar relatieve druk (drukopnemer waarde, gemeten aan de zuigkant van de pomp)
- S:** Tillöppstrycket angivet i bar relativt tryck (manometervärde mätt på pumpens sug sida)
- FIN:** Tulopaine ilmoitettuna baareina on suhteellinen paine (painemittarin lukema mitattu pumpun imupuolella)
- DK:** Tilløbstrykket angivet i bar relativt tryk (manometerværdi målt på pumpens sugeside)
- PL:** Ciśnienie na króćcu ssawnym pompy wyrażone w barach (mierzone manometrem na stronie ssawnej pompy)
- RU:** Давление на входе в барах (измерения производились во всасывающей части насоса)
- H:** Hozzáfolyási nyomás bar-ban, túlnyomás (nyomásmérő mért értéke a szivattyú szívóoldalán)
- SI:** Vhodni tlak v barih relativni tlak (izmerjena vrednost na sesalni strani črpalke)
- HR:** Ulazni tlak u barima relativnog tlaka (manometarski tlak izmjeren na usisnoj strani crpke)
- SER:** Ulazni pritisak je dat u barima relativnog pritiska (manometarska vrednost merena na usisnoj strani pumpe)
- RO:** Presiunea de intrare exprimată în bar ca presiune relativă (valoarea măsurată de manometru pe partea de aspirație a pompei)
- BG:** Относително входно налягане в бар (стойност на манометъра в смукателната страна на помпата)
- CZ:** Tlak na sání vyjádřený v barech je relativní tlak (hodnota na manometru měřená na sací straně čerpadla)
- SK:** Vstupný tlak uvedený v baroch relatívneho tlaku (hodnota na manometru meraná na sacej strane čerpadla)
- EE:** Rõhk sisendis, antud baarides, on suhteline rõhk (manomeetri näit, mõõdetuna pumba imipoolel)

## 50 Hz, 2-pole

Pump type	p [bar]					
	20 °C	60 °C	90 °C	110 °C	120 °C	140 °C
TP 25-50R/2	0.1	0.1	0.1	0.8	1.4	3.1
TP 25-90R/2	0.1	0.1	0.1	0.8	1.4	3.1
TP 32-50R/2	0.1	0.1	0.1	0.8	1.4	3.1
TP 32-90R/2	0.1	0.1	0.1	0.8	1.4	3.1
TP(D) 32-60/2	0.1	0.1	0.2	1.0	1.5	3.2
TP(D) 32-120/2	0.1	0.2	0.7	1.5	2.0	3.7
TP(D) 32-150/2	0.1	0.3	0.8	1.6	2.1	3.8
TP(D) 32-180/2	0.5	0.7	1.2	2.0	2.5	4.2
TP(D) 32-230/2	0.7	0.9	1.4	2.2	2.7	4.4
TP(D) 32-200/2	0.1	0.1	0.2	0.9	1.5	3.1
TP(D) 32-250/2	0.1	0.1	0.3	1.0	1.6	3.2

Pump type	p [bar]					
	20 °C	60 °C	90 °C	110 °C	120 °C	140 °C
50 Hz, 2-pole						
TP(D) 32-320/2	0.1	0.1	0.6	1.3	1.9	3.5
TP(D) 32-380/2	0.1	0.2	0.7	1.4	2.0	3.6
TP(D) 32-460/2	0.1	0.2	0.7	1.4	1.9	3.6
TP(D) 32-580/2	0.2	0.4	0.9	1.6	2.2	3.8
TP 40-50/2	0.1	0.1	0.1	0.8	1.4	3.1
TP 40-90/2	0.1	0.1	0.1	0.8	1.4	3.1
TP(D) 40-60/2	0.1	0.1	0.5	1.2	1.8	3.5
TP(D) 40-120/2	0.1	0.1	0.4	1.2	1.7	3.4
TP(D) 40-180/2	0.1	0.2	0.7	1.5	2.0	3.7
TP(D) 40-190/2	0.1	0.3	0.8	1.6	2.1	3.8
TP(D) 40-230/2	0.7	0.9	1.4	2.2	2.7	4.4
TP(D) 40-270/2	0.7	0.9	1.4	2.2	2.7	4.4
TP(D) 40-240/2	0.1	0.1	0.4	1.1	1.7	3.3
TP(D) 40-300/2	0.1	0.1	0.4	1.1	1.6	3.3
TP(D) 40-360/2	0.2	0.4	0.9	1.6	2.1	3.8
TP(D) 40-470/2	0.1	0.1	0.4	1.1	1.6	3.3
TP(D) 40-580/2	0.2	0.4	0.9	1.6	2.1	3.8
TP(D) 50-60/2	0.1	0.1	0.4	1.1	1.7	3.4
TP(D) 50-120/2	0.1	0.2	0.7	1.5	2.0	3.7
TP(D) 50-180/2	0.1	0.2	0.7	1.4	2.0	3.7
TP(D) 50-160/2	0.1	0.1	0.1	0.8	1.4	3.0
TP(D) 50-190/2	0.1	0.1	0.1	0.8	1.4	3.0
TP(D) 50-240/2	0.1	0.1	0.1	0.8	1.4	3.0
TP(D) 50-290/2	0.1	0.1	0.2	0.9	1.5	3.1
TP(D) 50-360/2	0.1	0.1	0.2	1.0	1.5	3.1
TP(D) 50-430/2	0.1	0.1	0.4	1.1	1.6	3.3
TP(D) 50-440/2	0.1	0.1	0.4	1.1	1.6	3.3
TP(D) 50-570/2	0.1	0.3	0.8	1.6	2.1	3.7
TP(D) 50-710/2	0.6	0.8	1.3	2.0	2.6	4.2
TP(D) 50-830/2	0.5	0.7	1.2	2.0	2.5	4.1
TP(D) 50-960/2	1.0	1.2	1.7	2.4	3.0	4.6
TP(D) 65-60/2	0.1	0.3	0.8	1.5	2.1	3.8
TP(D) 65-120/2	0.5	0.7	1.2	2.0	2.5	4.2
TP(D) 65-180/2	0.3	0.5	1.0	1.8	2.3	4.0
TP(D) 65-190/2	0.1	0.1	0.1	0.7	1.3	2.9
TP(D) 65-230/2	0.1	0.1	0.1	0.8	1.4	3.0
TP(D) 65-260/2	0.1	0.1	0.1	0.8	1.4	3.0

Pump type	p [bar]					
	20 °C	60 °C	90 °C	110 °C	120 °C	140 °C
<b>50 Hz, 2-pole</b>						
TP(D) 65-340/2	0.1	0.1	0.2	0.9	1.4	3.1
TP(D) 65-410/2	0.1	0.1	0.2	0.9	1.4	3.1
TP(D) 65-460/2	0.1	0.1	0.2	1.0	1.5	3.1
TP(D) 65-550/2	0.1	0.1	0.3	1.0	1.6	3.2
TP(D) 65-660/2	0.1	0.1	0.4	1.1	1.6	3.3
TP(D) 65-720/2	0.1	0.1	0.6	1.3	1.9	3.5
TP(D) 65-930/2	0.6	0.8	1.3	2.0	2.6	4.2
TP(D) 80-120/2	1.2	1.4	1.9	2.7	3.2	4.9
TP(D) 80-140/2	0.1	0.2	0.7	1.4	1.9	3.6
TP(D) 80-180/2	0.1	0.1	0.3	1.1	1.6	3.2
TP(D) 80-210/2	0.1	0.1	0.4	1.1	1.7	3.3
TP(D) 80-240/2	0.1	0.1	0.5	1.3	1.8	3.4
TP(D) 80-250/2	0.1	0.3	0.8	1.6	2.1	3.7
TP(D) 80-330/2	0.1	0.2	0.7	1.4	2.0	3.6
TP(D) 80-400/2	0.2	0.4	0.9	1.6	2.2	3.8
TP(D) 80-520/2	0.1	0.1	0.6	1.4	1.9	3.5
TP(D) 80-570/2	0.1	0.3	0.8	1.6	2.1	3.7
TP(D) 80-700/2	0.6	0.8	1.3	2.1	2.6	4.2
TP(D) 100-120/2	1.9	2.1	2.6	3.4	3.9	5.6
TP(D) 100-160/2	0.1	0.1	0.6	1.3	1.9	3.5
TP(D) 100-200/2	0.1	0.1	0.4	1.2	1.7	3.3
TP(D) 100-240/2	0.1	0.1	0.5	1.3	1.8	3.4
TP(D) 100-250/2	0.6	0.8	1.3	2.0	2.5	4.2
TP(D) 100-310/2	0.6	0.8	1.3	2.0	2.6	4.2
TP(D) 100-360/2	0.6	0.8	1.3	2.0	2.5	4.2
TP(D) 100-390/2	1.0	1.2	1.7	2.4	3.0	4.6
TP(D) 100-480/2	1.5	1.7	2.2	2.9	3.5	5.1

**50 Hz, 4-pole**

Pump type	p [bar]					
	20 °C	60 °C	90 °C	110 °C	120 °C	140 °C
TP(D) 32-30/4	0.1	0.1	0.1	0.8	1.4	3.1
TP(D) 32-40/4	0.1	0.1	0.1	0.9	1.4	3.1
TP(D) 32-60/4	0.1	0.1	0.3	1.1	1.6	3.3
TP(D) 32-80/4	0.1	0.1	0.1	0.5	1.0	2.7
TP(D) 32-100/4	0.1	0.1	0.1	0.5	1.1	2.7
TP(D) 32-120/4	0.1	0.1	0.1	0.6	1.1	2.7
TP(D) 40-30/4	0.1	0.1	0.2	0.9	1.5	3.2
TP(D) 40-60/4	0.1	0.1	0.1	0.8	1.4	3.1
TP(D) 40-90/4	0.1	0.1	0.3	1.0	1.6	3.3
TP(D) 40-100/4	0.1	0.1	0.2	0.9	1.5	3.1
TP(D) 40-130/4	0.1	0.1	0.1	0.7	1.2	2.8
TP(D) 40-160/4	0.1	0.1	0.2	0.9	1.5	3.1
TP(D) 50-30/4	0.1	0.1	0.1	0.9	1.4	3.1
TP(D) 50-60/4	0.1	0.1	0.2	0.9	1.5	3.2
TP(D) 50-90/4	0.1	0.1	0.1	0.6	1.1	2.8
TP(D) 50-110/4	0.1	0.1	0.1	0.6	1.1	2.8
TP(D) 50-130/4	0.1	0.1	0.1	0.7	1.2	2.8
TP(D) 50-160/4	0.1	0.1	0.1	0.7	1.3	2.9
TP(D) 50-190/4	0.1	0.1	0.1	0.9	1.4	3.0
TP(D) 50-230/4	0.1	0.1	0.2	1.0	1.5	3.1
TP(D) 65-30/4	0.1	0.2	0.7	1.5	2.0	3.7
TP(D) 65-60/4	0.2	0.4	0.9	1.6	2.2	3.9
TP(D) 65-90/4	0.1	0.1	0.1	0.6	1.1	2.7
TP(D) 65-110/4	0.1	0.1	0.1	0.6	1.1	2.7
TP(D) 65-130/4	0.1	0.1	0.1	0.6	1.1	2.8
TP(D) 65-150/4	0.1	0.1	0.1	0.6	1.2	2.8
TP(D) 65-170/4	0.1	0.1	0.1	0.6	1.2	2.8
TP(D) 65-240/4	0.1	0.1	0.1	0.8	1.3	2.9
TP(D) 80-30/4	0.8	1.0	1.5	2.2	2.8	4.5
TP(D) 80-60/4	0.8	1.0	1.5	2.3	2.8	4.5
TP(D) 80-70/4	0.1	0.1	0.1	0.8	1.3	2.9
TP(D) 80-90/4	0.1	0.1	0.1	0.7	1.2	2.8
TP(D) 80-110/4	0.1	0.1	0.1	0.8	1.4	3.0
TP(D) 80-150/4	0.1	0.1	0.1	0.8	1.3	2.9
TP(D) 80-170/4	0.1	0.1	0.2	1.0	1.5	3.1
TP(D) 80-240/4	0.1	0.1	0.3	1.0	1.5	3.2

Pump type	p [bar]					
	20 °C	60 °C	90 °C	110 °C	120 °C	140 °C
<b>50 Hz, 4-pole</b>						
TP(D) 80-270/4	0.1	0.1	0.2	0.9	1.5	3.1
TP(D) 80-340/4	0.1	0.1	0.3	1.1	1.6	3.2
TP(D) 100-30/4	0.8	1.0	1.5	2.2	2.8	4.5
TP(D) 100-60/4	0.6	0.8	1.3	2.0	2.6	4.3
TP(D) 100-70/4	0.1	0.1	0.1	0.8	1.3	3.0
TP(D) 100-90/4	0.1	0.1	0.1	0.9	1.4	3.0
TP(D) 100-110/4	0.1	0.1	0.2	1.0	1.5	3.1
TP(D) 100-130/4	0.1	0.1	0.6	1.3	1.9	3.5
TP(D) 100-170/4	0.3	0.5	1.0	1.7	2.3	3.9
TP(D) 100-200/4	0.1	0.1	0.5	1.2	1.8	3.4
TP(D) 100-250/4	0.1	0.2	0.7	1.4	2.0	3.6
TP(D) 100-330/4	0.3	0.5	1.0	1.7	2.3	3.9
TP(D) 100-370/4	0.3	0.5	1.0	1.7	2.3	3.9
TP(D) 100-410/4	0.5	0.7	1.2	1.9	2.5	4.1
TP(D) 125-110/4	0.1	0.1	0.1	0.9	1.4	3.0
TP(D) 125-130/4	0.1	0.1	0.2	0.9	1.5	3.1
TP(D) 125-160/4	0.1	0.1	0.2	1.0	1.5	3.1
TP(D) 125-210/4	0.1	0.1	0.3	1.0	1.6	3.2
TP(D) 125-250/4	0.1	0.1	0.4	1.1	1.7	3.3
TP(D) 125-320/4	0.1	0.1	0.3	1.0	1.6	3.2
TP(D) 125-360/4	0.1	0.1	0.4	1.2	1.7	3.3
TP(D) 125-420/4	0.1	0.2	0.7	1.4	2.0	3.6
TP(D) 150-130/4	0.1	0.1	0.4	1.1	1.6	3.3
TP(D) 150-160/4	0.1	0.1	0.4	1.1	1.7	3.3
TP(D) 150-200/4	0.1	0.1	0.4	1.1	1.7	3.3
TP(D) 150-220/4	0.1	0.1	0.5	1.2	1.8	3.4
TP(D) 150-250/4	0.1	0.1	0.6	1.3	1.9	3.5
TP 150-260/4	0.6	0.8	1.3	2.0	2.6	4.2
TP 150-280/4	0.7	0.9	1.4	2.1	2.6	4.3
TP 150-340/4	0.9	1.1	1.6	2.4	2.9	4.5
TP 150-390/4	2.1	2.3	2.8	3.5	4.1	5.7
TP 200-180/4	1.4	1.6	2.1	2.8	3.4	5.0
TP 200-220/4	1.1	1.3	1.8	2.6	3.1	4.7
TP 200-250/4	1.1	1.3	1.8	2.6	3.1	4.7
TP 200-270/4	1.6	1.8	2.3	3.0	3.6	5.2
TP 200-320/4	1.7	1.9	2.4	3.1	3.6	5.3
TP 200-330/4	1.1	1.3	1.8	2.5	3.1	4.7

Pump type	p [bar]					
	20 °C	60 °C	90 °C	110 °C	120 °C	140 °C
<b>50 Hz, 4-pole</b>						
TP 200-360/4	1.2	1.4	1.9	2.6	3.2	4.8
TP 200-400/4	1.4	1.6	2.1	2.8	3.3	5.0
TP 200-410/4	2.3	2.5	3.0	3.7	4.3	5.9
TP 200-470/4	1.4	1.6	2.1	2.8	3.4	5.0
TP 200-530/4	1.6	1.8	2.3	3.0	3.6	5.2
TP 200-590/4	1.7	1.9	2.4	3.2	3.7	5.3
TP 200-660/4	2.9	3.1	3.6	4.3	4.9	6.5
<b>50 Hz, 6-pole</b>						
Pump type	p [bar]					
50 Hz, 6-pole	20 °C	60 °C	90 °C	110 °C	120 °C	140 °C
TP(D) 125-60/6	0.1	0.1	0.1	0.7	1.2	2.8
TP(D) 125-70/6	0.1	0.1	0.1	0.7	1.3	2.9
TP(D) 125-90/6	0.1	0.1	0.1	0.7	1.2	2.9
TP(D) 125-110/6	0.1	0.1	0.1	0.8	1.3	2.9
TP(D) 125-140/6	0.1	0.1	0.1	0.7	1.3	2.9
TP(D) 125-170/6	0.1	0.1	0.1	0.8	1.4	3.0
TP(D) 150-60/6	0.1	0.1	0.1	0.7	1.3	2.9
TP(D) 150-70/6	0.1	0.1	0.1	0.7	1.3	2.9
TP(D) 150-90/6	0.1	0.1	0.1	0.8	1.3	2.9
TP(D) 150-110/6	0.1	0.1	0.1	0.8	1.3	3.0

**60 Hz, 2-pole**

<b>Pump type</b>	<b>p [bar]</b>					
	<b>20 °C</b>	<b>60 °C</b>	<b>90 °C</b>	<b>110 °C</b>	<b>120 °C</b>	<b>140 °C</b>
TP 32-80/2	0.4	0.4	0.4	1.2	1.7	3.4
TP 32-160/2	0.4	0.6	1.1	1.9	2.4	4.1
TP 32-220/2	0.7	0.9	1.4	2.2	2.7	4.4
TP 32-260/2	0.7	0.9	1.4	2.2	2.7	4.4
TP 32-330/2	0.7	0.9	1.4	2.2	2.7	4.4
TP(D) 32-300/2	0.1	0.1	0.1	0.7	1.2	2.8
TP(D) 32-360/2	0.1	0.1	0.1	0.7	1.2	2.8
TP(D) 32-450/2	0.1	0.1	0.1	0.7	1.2	2.8
TP(D) 32-550/2	0.1	0.1	0.1	0.7	1.2	2.9
TP(D) 32-680/2	0.1	0.1	0.2	0.9	1.5	3.1
TP(D) 32-820/2	0.5	0.7	1.2	1.9	2.5	4.1
TP 40-80/2	0.1	0.3	0.8	1.6	2.1	3.8
TP 40-160/2	0.1	0.2	0.7	1.5	2.0	3.7
TP 40-240/2	0.4	0.6	1.1	1.9	2.4	4.1
TP 40-270/2	0.7	0.9	1.4	2.2	2.7	4.4
TP 40-330/2	0.7	0.9	1.4	2.2	2.7	4.4
TP 40-390/2	0.7	0.9	1.4	2.2	2.7	4.4
TP(D) 40-370/2	0.1	0.1	0.1	0.8	1.3	2.9
TP(D) 40-450/2	0.1	0.1	0.1	0.8	1.4	3.0
TP(D) 40-550/2	0.1	0.1	0.1	0.8	1.4	3.0
TP(D) 40-740/2	0.1	0.1	0.3	1.0	1.6	3.2
TP(D) 40-850/2	0.1	0.1	0.6	1.3	1.9	3.5
TP(D) 40-930/2	0.3	0.5	1.0	1.7	2.3	3.9
TP 50-80/2	0.1	0.1	0.6	1.4	1.9	3.6
TP 50-160/2	0.4	0.6	1.1	1.9	2.4	4.1
TP 50-240/2	0.3	0.5	1.0	1.8	2.3	4.0
TP(D) 50-250/2	0.1	0.1	0.2	1.0	1.5	3.1
TP(D) 50-300/2	0.1	0.1	0.3	1.0	1.6	3.2
TP(D) 50-350/2	0.1	0.1	0.3	1.0	1.6	3.2
TP(D) 50-410/2	0.1	0.1	0.4	1.1	1.6	3.3
TP(D) 50-440/2	0.1	0.1	0.5	1.2	1.8	3.4
TP(D) 50-540/2	0.1	0.2	0.7	1.4	2.0	3.6
TP(D) 50-720/2	0.1	0.3	0.8	1.6	2.1	3.7
TP(D) 50-790/2	0.5	0.7	1.2	1.9	2.5	4.1
TP(D) 50-880/2	0.8	1.0	1.5	2.2	2.8	4.4
TP(D) 50-1050/2	1.1	1.3	1.8	2.5	3.1	4.7
TP 65-80/2	0.6	0.8	1.3	2.1	2.6	4.3

Pump type	p [bar]					
	20 °C	60 °C	90 °C	110 °C	120 °C	140 °C
60 Hz, 2-pole						
TP 65-160/2	1.1	1.3	1.8	2.6	3.1	4.8
TP 65-240/2	0.9	1.1	1.6	2.4	2.9	4.6
TP(D) 65-220/2	0.1	0.1	0.2	0.9	1.4	3.1
TP(D) 65-260/2	0.1	0.1	0.2	0.9	1.5	3.1
TP(D) 65-340/2	0.1	0.1	0.2	1.0	1.5	3.1
TP(D) 65-390/2	0.1	0.1	0.3	1.0	1.5	3.2
TP(D) 65-480/2	0.1	0.1	0.3	1.0	1.6	3.2
TP(D) 65-540/2	0.1	0.1	0.3	1.1	1.6	3.2
TP(D) 65-630/2	0.1	0.1	0.4	1.1	1.7	3.3
TP(D) 65-740/2	0.1	0.1	0.6	1.3	1.9	3.5
TP(D) 65-910/2	0.1	0.2	0.7	1.5	2.0	3.6
TP(D) 65-1050/2	0.1	0.2	0.7	1.5	2.0	3.6
TP 80-160/2	2.1	2.3	2.8	3.6	4.1	5.8
TP(D) 80-200/2	0.5	0.7	1.2	1.9	2.5	4.1
TP(D) 80-240/2	0.1	0.2	0.7	1.4	2.0	3.6
TP(D) 80-290/2	0.1	0.3	0.8	1.5	2.1	3.7
TP(D) 80-330/2	0.2	0.4	0.9	1.7	2.2	3.8
TP(D) 80-400/2	0.6	0.8	1.3	2.1	2.6	4.2
TP(D) 80-480/2	0.1	0.3	0.8	1.5	2.1	3.7
TP(D) 80-530/2	0.2	0.4	0.9	1.6	2.1	3.8
TP(D) 80-640/2	0.6	0.8	1.3	2.0	2.6	4.2
TP(D) 80-750/2	0.6	0.8	1.3	2.0	2.6	4.2
TP(D) 100-230/2	0.4	0.6	1.1	1.9	2.4	4.0
TP(D) 100-300/2	0.2	0.4	0.9	1.6	2.2	3.8
TP(D) 100-370/2	0.3	0.5	1.0	1.7	2.3	3.9
TP(D) 100-350/2	0.9	1.1	1.6	2.3	2.9	4.5
TP(D) 100-380/2	1.2	1.4	1.9	2.6	3.2	4.8
TP(D) 100-530/2	1.7	1.9	2.4	3.2	3.7	5.3
TP(D) 100-630/2	1.4	1.6	2.1	2.8	3.3	5.0
TP(D) 100-700/2	3.0	3.2	3.7	4.4	5.0	6.6

**60 Hz, 4-pole**

<b>Pump type</b>	<b>p [bar]</b>					
	<b>20 °C</b>	<b>60 °C</b>	<b>90 °C</b>	<b>110 °C</b>	<b>120 °C</b>	<b>140 °C</b>
TP 32-40/4	0.1	0.1	0.1	0.9	1.4	3.1
TP 32-80/4	0.1	0.1	0.5	1.3	1.8	3.5
TP(D) 32-120/4	0.1	0.1	0.1	0.7	1.3	2.9
TP(D) 32-140/4	0.1	0.1	0.1	0.7	1.3	2.9
TP(D) 32-190/4	0.1	0.1	0.1	0.8	1.4	3.0
TP 40-40/4	0.1	0.1	0.3	1.1	1.6	3.3
TP 40-80/4	0.1	0.1	0.2	1.0	1.5	3.2
TP(D) 40-120/4	0.1	0.1	0.1	0.5	1.1	2.7
TP(D) 40-160/4	0.1	0.1	0.1	0.6	1.2	2.8
TP(D) 40-190/4	0.1	0.1	0.1	0.7	1.2	2.8
TP(D) 40-220/4	0.1	0.1	0.2	0.9	1.4	3.1
TP 50-40/4	0.1	0.1	0.3	1.1	1.6	3.3
TP 50-80/4	0.1	0.1	0.3	1.1	1.6	3.3
TP(D) 50-110/4	0.1	0.1	0.1	0.6	1.2	2.8
TP(D) 50-120/4	0.1	0.1	0.1	0.7	1.2	2.8
TP(D) 50-140/4	0.1	0.1	0.1	0.7	1.3	2.9
TP(D) 50-190/4	0.1	0.1	0.1	0.8	1.4	3.0
TP(D) 50-240/4	0.1	0.1	0.2	0.9	1.5	3.1
TP(D) 50-270/4	0.1	0.1	0.3	1.0	1.6	3.2
TP(D) 50-340/4	0.1	0.2	0.7	1.4	2.0	3.6
TP 65-40/4	0.4	0.6	1.1	1.9	2.4	4.1
TP 65-80/4	0.7	0.9	1.4	2.2	2.7	4.4
TP(D) 65-130/4	0.1	0.1	0.1	0.6	1.2	2.8
TP(D) 65-150/4	0.1	0.1	0.1	0.6	1.2	2.8
TP(D) 65-190/4	0.1	0.1	0.1	0.6	1.2	2.8
TP(D) 65-230/4	0.1	0.1	0.1	0.7	1.3	2.9
TP(D) 65-310/4	0.1	0.1	0.1	0.7	1.3	2.9
TP(D) 65-330/4	0.1	0.1	0.1	0.3	0.8	2.5
TP 80-40/4	1.5	1.7	2.2	3.0	3.5	5.2
TP 80-80/4	1.6	1.8	2.3	3.1	3.6	5.3
TP(D) 80-110/4	0.1	0.1	0.1	0.8	1.4	3.0
TP(D) 80-150/4	0.1	0.1	0.1	0.8	1.3	2.9
TP(D) 80-170/4	0.1	0.1	0.1	0.8	1.3	3.0
TP(D) 80-230/4	0.1	0.1	0.3	1.0	1.6	3.2
TP(D) 80-280/4	0.1	0.1	0.2	1.0	1.5	3.1
TP(D) 80-340/4	0.1	0.1	0.3	1.0	1.6	3.2

Pump type	p [bar]					
	20 °C	60 °C	90 °C	110 °C	120 °C	140 °C
60 Hz, 4-pole						
TP(D) 80-410/4	0.1	0.1	0.5	1.2	1.8	3.4
TP(D) 80-460/4	0.1	0.1	0.6	1.3	1.9	3.5
TP(D) 80-510/4	0.1	0.2	0.7	1.5	2.0	3.6

Pump type	p [bar]					
	20 °C	60 °C	90 °C	110 °C	120 °C	140 °C
60 Hz, 4-pole						
TP 100-40/4	1.4	1.6	2.1	2.9	3.4	5.1
TP 100-80/4	1.2	1.4	1.9	2.7	3.2	4.9
TP(D) 100-100/4	0.1	0.1	0.2	0.9	1.5	3.1
TP(D) 100-130/4	0.1	0.1	0.3	1.0	1.6	3.2
TP(D) 100-170/4	0.1	0.1	0.6	1.3	1.9	3.5
TP(D) 100-200/4	0.1	0.1	0.4	1.1	1.7	3.3
TP(D) 100-240/4	0.1	0.1	0.6	1.3	1.9	3.5
TP(D) 100-290/4	0.5	0.7	1.2	2.0	2.5	4.1
TP(D) 100-340/4	0.6	0.8	1.3	2.0	2.6	4.2
TP(D) 100-390/4	0.7	0.9	1.4	2.1	2.7	4.3
TP(D) 100-470/4	0.9	1.1	1.6	2.3	2.9	4.5
TP(D) 125-130/4	0.1	0.1	0.3	1.0	1.6	3.2
TP(D) 125-160/4	0.1	0.1	0.3	1.1	1.6	3.2
TP(D) 125-210/4	0.1	0.1	0.3	1.0	1.6	3.2
TP(D) 125-260/4	0.1	0.1	0.4	1.2	1.7	3.3
TP(D) 125-320/4	0.1	0.1	0.3	1.1	1.6	3.2
TP(D) 125-360/4	0.1	0.1	0.4	1.1	1.7	3.3
TP(D) 125-430/4	0.1	0.1	0.5	1.3	1.8	3.4
TP(D) 125-490/4	0.1	0.3	0.8	1.5	2.1	3.7
TP(D) 150-180/4	0.1	0.2	0.7	1.4	1.9	3.6
TP(D) 150-210/4	0.1	0.2	0.7	1.4	2.0	3.6
TP(D) 150-240/4	0.1	0.2	0.7	1.5	2.0	3.6
TP(D) 150-300/4	0.1	0.3	0.8	1.5	2.1	3.7
TP 150-360/4	1.4	1.6	2.1	2.9	3.4	5.1
TP 150-400/4	0.2	0.4	0.9	1.7	2.2	3.9
TP 150-460/4	0.6	0.8	1.3	2.0	2.6	4.3
TP 150-500/4	0.7	0.9	1.4	2.2	2.7	4.4
TP 200-270/4	2.4	2.6	3.1	3.9	4.4	6.1
TP 200-290/4	2.3	2.5	3.0	3.7	4.3	6.0
TP 200-330/4	2.1	2.3	2.8	3.5	4.1	5.8
TP 200-400/4	2.8	3.0	3.5	4.2	4.8	6.5
TP 200-430/4	2.5	2.7	3.2	4.0	4.5	6.2
TP 200-490/4	2.0	2.2	2.7	3.5	4.0	5.7
TP 200-500/4	3.1	3.3	3.8	4.5	5.1	6.8
TP 200-540/4	2.3	2.5	3.0	3.7	4.3	6.0
TP 200-600/4	2.5	2.7	3.2	4.0	4.5	6.2
TP 200-680/4	2.7	2.9	3.4	4.2	4.7	6.4
TP 200-770/4	3.0	3.2	3.7	4.4	5.0	6.7

## Maximum sound pressure level

Three-phase motors [kW]	50 Hz [dB(A)]		60 Hz [dB(A)]	
	2-pole	4-pole	2-pole	4-pole
0.12	<70	<70	<70	<70
0.18	<70	<70	<70	<70
0.25	56	41	<70	45
0.37	56	45	57	45
0.55	57	42	56	45
0.75	56	42	57	49
1.1	59	50	63	53
1.5	58	50	64	53
2.2	60	52	65	55
3.0	59	52	64	55
4.0	63	54	68	57
5.5	63	62	67	62
7.5	68	62	73	62
11.0	70	66	70	66
15.0	70	66	70	66
18.5	70	63	70	63
22.0	70	63	70	63
30.0	71	65	71	65
37.0	71	66	71	65
45.0	71	66	75	65
55.0	71	67	75	68
75.0	73	70	77	71
90.0	73	70	77	71
110.0	76	70	81	75
132.0	76	70	81	75
160.0	76	70	81	75

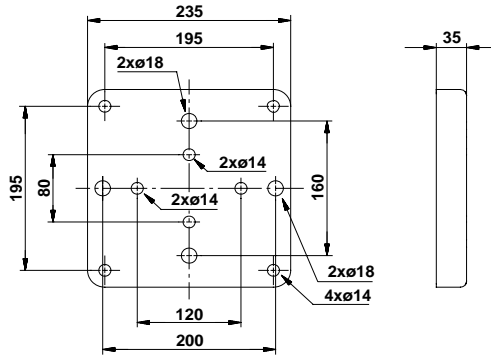

Fig. A

TM00 9835 0497

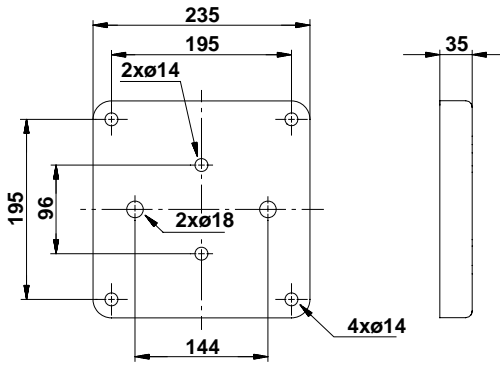

Fig. B

TM00 3755 5097

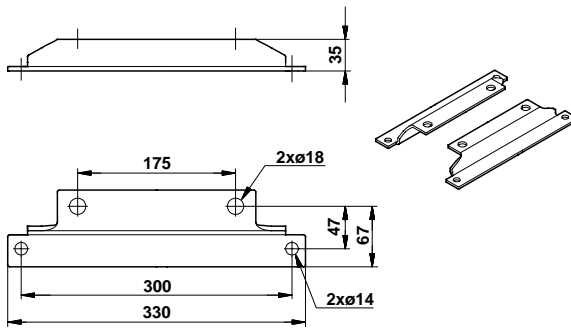

Fig. C

TM02 5336 2602

**Argentina**

Bombas GRUNDFOS de Argentina S.A.  
Ruta Panamericana km. 37.500 Lote  
34A  
1619 - Garin  
Pcia. de Buenos Aires  
Phone: +54-3327 414 444  
Telefax: +54-3327 411 111

**Australia**

GRUNDFOS Pumps Pty. Ltd.  
P.O. Box 2040  
Regency Park  
South Australia 5942  
Phone: +61-8-8461-4611  
Telefax: +61-8-8340 0155

**Austria**

GRUNDFOS Pumpen Vertrieb  
Ges.m.b.H.  
Grundfosstraße 2  
A-5082 Grödig/Salzburg  
Tel.: +43-6246-883-0  
Telefax: +43-6246-883-30

**Belgium**

N.V. GRUNDFOS Bellux S.A.  
Boomssteentweg 81-83  
B-2630 Aartselaar  
Tél.: +32-3-870 7300  
Télécopie: +32-3-870 7301

**Belorussia**

Представительство ГРУНДФОС в  
Минске  
220090 Минск ул.Опешеева 14  
Телефон: (8632) 62-40-49  
Факс: (8632) 62-40-49

**Bosnia/Herzegovina**

GRUNDFOS Sarajevo  
Paromlinska br. 16,  
BH-71000 Sarajevo  
Phone: +387 33 713290  
Telefax: +387 33 231795

**Brazil**

Mark GRUNDFOS Ltda.  
Av. Humberto de Alencar Castelo  
Branco, 830  
CEP 09850 - 300  
São Bernardo do Campo - SP  
Phone: +55-11 4393 5533  
Telefax: +55-11 4343 5015

**Bulgaria**

GRUNDFOS Pumpen Vertrieb  
Representative Office - Bulgaria  
Bulgaria, 1421 Sofia  
Lozenetz District  
105-107 Arsenalski Blvd.  
Phone: +359 2963 3820, 2963 5653  
Telefax: +359 2963 1305

**Canada**

GRUNDFOS Canada Inc.  
2941 Brighton Road  
Oakville, Ontario  
L6H 6C9  
Phone: +1-905 829 9533  
Telefax: +1-905 829 9512

**China**

GRUNDFOS Pumps (Shanghai) Co. Ltd.  
51 Floor, Raffles City  
No. 268 Xi Zang Road, (M)  
Shanghai 200001  
PRC  
Phone: +86-021-612 252 22  
Telefax: +86-021-612 253 33

**Croatia**

GRUNDFOS predstavništvo Zagreb  
Cebini 37, Buzin  
HR-10000 Zagreb  
Phone: +385 1 6595 400  
Telefax: +385 1 6595 499

**Czech Republic**

GRUNDFOS s.r.o.  
Čajkovského 21  
779 00 Olomouc  
Phone: +420-585-716 111  
Telefax: +420-585-716 299

**Denmark**

GRUNDFOS DK A/S  
Martin Bachs Vej 3  
DK-8550 Bjerningbro  
Tlf.: +45-87 50 50 50  
Telefax: +45-87 50 51 51  
E-mail: info\_GDK@grundfos.com  
www.grundfos.com/DK

**Estonia**

GRUNDFOS Pumps Eesti OÜ  
Pelerburli tee 92G  
11415 Tallinn  
Tel: + 372 606 1691  
Fax: + 372 606 1690

**Finland**

OY GRUNDFOS Pumput AB  
Mestarinie 11  
FIN-01730 Vantaa  
Phone: +358-3066 5650  
Telefax: +358-3066 56550

**France**

Pompes GRUNDFOS Distribution S.A.  
Parc d'Activités de Cheneses  
57, rue de Malacome  
F-38290 St. Quentin Fallavier (Lyon)  
Tél.: +33-4 74 82 15 15  
Télécopie: +33-4 74 94 10 51

**Germany**

GRUNDFOS GMBH  
Schlüterstr. 33  
40699 Erkrath  
Tel.: +49-(0) 211 929 69-0  
Telefax: +49-(0) 211 929 69-3799  
e-mail: info.essence@grundfos.de  
Service in Deutschland:  
e-mail: kundendienst@grundfos.de

**Greece**

GRUNDFOS Hellas A.E.B.E.  
20th km. Athinon-Markopoulou Av.  
P.O. Box 71  
GR-19002 Peania  
Phone: +0030-210-66 83 400  
Telefax: +0030-210-66 46 273

**Hong Kong**

GRUNDFOS Pumps (Hong Kong) Ltd.  
Unit 1, Ground floor  
Siu Wai Industrial Centre  
29-33 Wing Hong Street &  
68 King Lam Street, Cheung Sha Wan  
Kowloon  
Phone: +852-27861706 / 27861741  
Telefax: +852-27858664

**Hungary**

GRUNDFOS Hungária Kft.  
Park u. 8  
H-2045 Törökbalint,  
Phone: +36-23 511 110  
Telefax: +36-23 511 111

**India**

GRUNDFOS Pumps India Private Limited  
118 Old Mahaballipuram Road  
Thoraiakkam  
Chennai 600 096  
Phone: +91-44 2496 6800

**Indonesia**

PT GRUNDFOS Pempa  
Jl. Rawa Sumur III, Blok III / CC-1  
Kawasan Industri, Pulogadung  
Jakarta 13930  
Phone: +62-21-460 6909  
Telefax: +62-21-460 6910 / 460 6901

**Ireland**

GRUNDFOS (Ireland) Ltd.  
Unit A, Merrywell Business Park  
Ballymount Road Lower  
Dublin 12  
Phone: +353-1-4089 800  
Telefax: +353-1-4089 830

**Italy**

GRUNDFOS Pompe Italia S.r.l.  
Via Gran Sasso 4  
I-20060 Trucazzano (Milano)  
Tel.: +39-02-95838112  
Telefax: +39-02-95309290 / 95838461

**Japan**

GRUNDFOS Pumps K.K.  
Gotanda Metalion Bldg., 5F,  
5-21-15, Higashi-gotanda  
Shigawaku-ku, Tokyo  
141-0022 Japan  
Phone: +81 35 448 1391  
Telefax: +81 35 448 9619

**Korea**

GRUNDFOS Pumps Korea Ltd.  
6th Floor, Aju Building 679-5  
Yeoksam-dong, Kangnam-ku, 135-916  
Seoul, Korea  
Phone: +82-2-5317 600  
Telefax: +82-2-5633 725

**Latvia**

SIA GRUNDFOS Pumps Latvia  
Dzeglava biznesa centrs  
Augusta Dzeglava iela 60, LV-1035, Rīga,  
Tālr.: + 371 714 9640, 7 149 641  
Fakss: + 371 914 9646

**Lithuania**

GRUNDFOS Pumps UAB  
Smolensko g. 6  
LT-03201 Vilnius  
Tel: + 370 52 395 430  
Fax: + 370 52 395 431

**Malaysia**

GRUNDFOS Pumps Sdn. Bhd.  
7 Jalan Peguam U1/25  
Glenmarie Industrial Park  
40150 Shah Alam  
Selangor  
Phone: +60-3-5569 2922  
Telefax: +60-3-5569 2866

**México**

Bombas GRUNDFOS de México S.A. de  
C.V.  
Boulevard TLC No. 15  
Parque Industrial Stiva Aeropuerto  
Apodaca, N.L. 66600  
Phone: +52-81-8144 4000  
Telefax: +52-81-8144 4010

**Netherlands**

GRUNDFOS Netherlands  
Veluwezoom 35  
1326 AE Almere  
Postbus 22015  
1302 CA ALMERE  
Tel.: +31-88-478 6336  
Telefax: +31-88-478 6332  
e-mail: info\_gnl@grundfos.com

**New Zealand**

GRUNDFOS Pumps NZ Ltd.  
17 Beatrice Tinsley Crescent  
North Harbour Industrial Estate  
Albany, Auckland  
Phone: +64-9-415 3240  
Telefax: +64-9-415 3250

**Norway**

GRUNDFOS Pumper A/S  
Stramsveien 344  
Postboks 235, Leirdal  
N-1011 Oslo  
Tlf.: +47-22 90 47 00  
Telefax: +47-22 32 21 50

**Poland**

GRUNDFOS Pompy Sp. z o.o.  
ul. Klonowa 23  
Baranowo k. Poznania  
PL-62-081 Przewiermierz  
Tel: (+48-61) 650 13 00  
Fax: (+48-61) 650 13 50

**Portugal**

Bombas GRUNDFOS Portugal, S.A.  
Rua Calvet de Magalhães, 241  
Apartado 1079  
P-2770-153 Paço de Arcos  
Tel.: +351-21-440 76 00  
Telefax: +351-21-440 76 90

**România**

GRUNDFOS Pompe România SRL  
Bd. Biruintei, nr 103  
Pantelimon county Ilfov  
Phone: +40 21 200 4100  
Telefax: +40 21 200 4101  
E-mail: romania@grundfos.ro

**Russia**

ООО Грундфос  
Россия, 109544 Москва, ул. Школьная  
39  
Тел. (+7) 495 737 30 00, 564 88 00  
Факс (+7) 495 737 75 36, 564 88 11  
E-mail grundfos.moscow@grundfos.com

**Serbia**

GRUNDFOS Predstavništvo Beograd  
Dr. Milutina Vukovića 2a/29  
YU-11000 Beograd  
Phone: +381 11 26 47 877 / 11 26 47  
496  
Telefax: +381 11 26 48 340

**Singapore**

GRUNDFOS (Singapore) Pte. Ltd.  
24 Tuas West Road  
Jurong Town  
Singapore 638381  
Phone: +65-6865 1222  
Telefax: +65-6861 8402

**Slovenia**

GRUNDFOS PUMPEM VERTRIEB  
Ges.m.b.H.,  
Podružnica Ljubljana  
Blatnica 1, SI-1236 Trzin  
Phone: +386 1 563 5338  
Telefax: +386 1 563 2098  
E-mail: slovenia@grundfos.si

**Spain**

Bombas GRUNDFOS España S.A.  
Camino de la Fuenteclilla, s/n  
E-28110 Algete (Madrid)  
Tel.: +34-91-848 8800  
Telefax: +34-91-628 0465

**Sweden**

GRUNDFOS AB  
(Box 333) Lunnagårdsgatan 6  
431 24 Mölndal  
Tel.: +46(0)771-32 23 00  
Telefax: +46(0)31-331 94 60

**Switzerland**

GRUNDFOS Pumpen AG  
Bruggacherstrasse 10  
CH-8117 Fällanden/ZH  
Tel.: +41-1-806 8111  
Telefax: +41-1-806 8115

**Taiwan**

GRUNDFOS Pumps (Taiwan) Ltd.  
7 Floor, 219 Min-Chuan Road  
Taichung, Taiwan, R.O.C.  
Phone: +886-4-2305 0866  
Telefax: +886-4-2305 0878

**Thailand**

GRUNDFOS (Thailand) Ltd.  
94/1768 Moo 12, Bangna-Trad Rd., K. M.  
3,  
Bangna, Phrakhanong  
Bangkok 10260  
Phone: +66-2-744 1785... 91  
Telefax: +66-2-744 1775... 6

**Turkey**

GRUNDFOS POMPA San. ve Tic. Ltd.  
Şti.  
Gezbe Organize Sanayi Bölgesi  
İnsan deste Caddesi,  
2. yol 200, Sokak No. 204  
41490 Gebze/ Kocaeli  
Phone: +90 - 262-679 7979  
Telefax: +90 - 262-679 7905  
E-mail: sats@grundfos.com

**Ukraine**

ТОВ ГРУНДФОС УКРАЇНА  
01010 Київ, Бун. Московська 86,  
Тел.: (+38 044) 390 40 50  
Факс: (+38 044) 390 40 59  
E-mail: ukraine@grundfos.com

**United Arab Emirates**

GRUNDFOS Gulf Distribution  
P.O. Box 16769  
Jebel Ali Free Zone  
Dubai  
Phone: +971-4 - 8815 166  
Telefax: +971-4-8815 136

**United Kingdom**

GRUNDFOS Pumps Ltd.  
Grovebury Road  
Leighton Buzzard/Beds. LU7 8TL  
Phone: +44-1525-850000  
Telefax: +44-1525-850011

**U.S.A.**

GRUNDFOS Pumps Corporation  
17100 West 118th Terrace  
Olathe, Kansas 66061  
Phone: +1-913-227-3400  
Telefax: +1-913-227-3500

**Usbekistan**

Представительство ГРУНДФОС в  
Ташкенте  
700000 Ташкент ул.Усмана Носира 1-й  
улицы 5  
Телефон: (3712) 55-68-15  
Факс: (3712) 53-36-35

<b>96404999</b> 0308	<b>190</b>
Repl. 96404999 0207	