

SQ, SQE

Installation and operating instructions

- (GB) (D) (F) (I) (E) (P) (GR) (NL) (S) (FIN) (DK)
(PL) (RU) (H) (SI) (HR) (YU) (RO) (BG) (CZ) (SK) (TR)
(EE) (LT) (LV)



(GB) Declaration of Conformity

We **Grundfos** declare under our sole responsibility that the products **SQ** and **SQE**, to which this declaration relates, are in conformity with the Council Directives on the approximation of the laws of the EC Member States relating to

- Machinery (98/37/EC).
Standard used: EN ISO 12100.
- Electromagnetic compatibility (89/336/EEC).
Standards used: EN 55014-1, EN 55014-2, EN 61000-3-2 and EN 61000-3-3.
- Electrical equipment designed for use within certain voltage limits (73/23/EEC) [95].
Standards used: EN 60335-1: 1994 and EN 60335-2-41: 1996.

(F) Déclaration de Conformité

Nous **Grundfos** déclarons sous notre seule responsabilité que les produits **SQ** et **SQE** auxquels se réfère cette déclaration sont conformes aux Directives du Conseil concernant le rapprochement des législations des Etats membres CE relatives à

- Machines (98/37/CE).
Standard utilisé: EN ISO 12100.
- Compatibilité électromagnétique (89/336/CEE).
Standards utilisés: EN 55014-1, EN 55014-2, EN 61000-3-2 et EN 61000-3-3.
- Matériel électrique destiné à employer dans certaines limites de tension (73/23/CEE) [95].
Standards utilisés: EN 60335-1: 1994 et EN 60335-2-41: 1996.

(E) Declaración de Conformidad

Nosotros **Grundfos** declaramos bajo nuestra única responsabilidad que los productos **SQ** y **SQE** a los cuales se refiere esta declaración son conformes con las Directivas del Consejo relativas a la aproximación de las legislaciones de los Estados Miembros de la CE sobre

- Máquinas (98/37/CE).
Norma aplicada: EN ISO 12100.
- Compatibilidad electromagnética (89/336/CEE).
Normas aplicadas: EN 55014-1, EN 55014-2, EN 61000-3-2 y EN 61000-3-3.
- Material eléctrico destinado a utilizarse con determinadas límites de tensión (73/23/CEE) [95].
Normas aplicadas: EN 60335-1: 1994 y EN 60335-2-41: 1996.

(GR) Δήλωση Συμμόρφωσης

Εμείς η **Grundfos** δηλώνουμε με αποκλειστικά δική μας ευθύνη ό τι τα προϊόντα **SQ** και **SQE** συμμορφώνονται με την Οδηγία του Συμβουλίου επί της σύγκλισης των νόμων των Κρατών Μελών της Ευρωπαϊκής Ένωσης σε σχέση με τα

- Μηχανήματα (98/37/EC).
Πρότυπο που χρησιμοποιήθηκε: EN ISO 12100.
- Ηλεκτρομαγνητική συμβατότητα (89/336/EEC).
Πρότυπα που χρησιμοποιήθηκαν: EN 55014-1, EN 55014-2, EN 61000-3-2 και EN 61000-3-3.
- Ηλεκτρικές συσκευές σχεδιασμένες για χρήση εντός ορισμένων ορίων ηλεκτρικής τάσης (73/23/EEC) [95].
Πρότυπα που χρησιμοποιήθηκαν: EN 60335-1: 1994 και EN 60335-2-41: 1996.

(S) Försäkran om överensstämmelse

Vi **Grundfos** försäkrar under ansvar, att produkterna **SQ** och **SQE**, som omfattas av denna försäkran, är i överensstämmelse med Rådets Direktiv om inbördes närmande till EU-medlemsstaternas lagstiftning, avseende

- Maskinell utrustning (98/37/EC).
Använd standard: EN ISO 12100.
- Elektromagnetisk kompatibilitet (89/336/EC).
Använda standarder: EN 55014-1, EN 55014-2, EN 61000-3-2 och EN 61000-3-3.
- Elektrisk material avsedd för användning inom vissa spänningsgränser (73/23/EC) [95].
Använda standarder: EN 60335-1: 1994 och EN 60335-2-41: 1996.

(D) Konformitätserklärung

Wir **Grundfos** erklären in alleiniger Verantwortung, dass die Produkte **SQ** und **SQE**, auf die sich diese Erklärung bezieht, mit den folgenden Richtlinien des Rates zur Angleichung der Rechtsvorschriften der EG-Mitgliedstaaten übereinstimmen

- Maschinen (98/37/EG).
Norm, die verwendet wurde: EN ISO 12100.
- Elektromagnetische Verträglichkeit (89/336/EWG).
Normen, die verwendet wurden: EN 55014-1, EN 55014-2, EN 61000-3-2 und EN 61000-3-3.
- Elektrische Betriebsmittel zur Verwendung innerhalb bestimmter Spannungsgrenzen (73/23/EWG) [95].
Normen, die verwendet wurden: EN 60335-1: 1994 und EN 60335-2-41: 1996.

(I) Dichiarazione di Conformità

Noi **Grundfos** dichiariamo sotto la nostra esclusiva responsabilità che i prodotti **SQ** e **SQE** ai quali questa dichiarazione se riferisce sono conformi alle Direttive del Consiglio concernente il ravvicinamento delle legislazioni degli Stati membri CE relative a

- Macchine (98/37/CE).
Standard usato: EN ISO 12100.
- Compatibilità elettromagnetica (89/336/CEE).
Standard usati: EN 55014-1, EN 55014-2, EN 61000-3-2 e EN 61000-3-3.
- Materiale elettrico destinato ad essere utilizzato entro certi limiti di tensione (73/23/CEE) [95].
Standard usati: EN 60335-1: 1994 e EN 60335-2-41: 1996.

(P) Declaração de Conformidade

Nós **Grundfos** declaramos sob nossa única responsabilidade que os produtos **SQ** e **SQE** aos quais se refere esta declaração estão em conformidade com as Diretivas do Conselho das Comunidades Europeias relativas à aproximação das legislações dos Estados Membros respeitantes à

- Máquinas (98/37/CE).
Norma utilizada: EN ISO 12100.
- Compatibilidade eletromagnética (89/336/CEE).
Normas utilizadas: EN 55014-1, EN 55014-2, EN 61000-3-2 e EN 61000-3-3.
- Material eléctrico destinado a ser utilizado dentro de certos limites de tensão (73/23/CEE) [95].
Normas utilizadas: EN 60335-1: 1994 e EN 60335-2-41: 1996.

(NL) Overeenkomstigheidsverklaring

Wij **Grundfos** verklaren geheel onder eigen verantwoordelijkheid dat de producten **SQ** en **SQE** waarop deze verklaring betrekking heeft in overeenstemming zijn met de Richtlijnen van de Raad inzake de onderlinge aanpassing van de wetgevingen van de Lid-Staten betreffende

- Machines (98/37/EG).
Norm: EN ISO 12100.
- Elektromagnetische compatibiliteit (89/336/EEG).
Normen: EN 55014-1, EN 55014-2, EN 61000-3-2 en EN 61000-3-3.
- Elektrisch materiaal bestemd voor gebruik binnen bepaalde spanningsgrenzen (73/23/EEG) [95].
Normen: EN 60335-1: 1994 en EN 60335-2-41: 1996.

(FIN) Vastaavuusvakuutus

Me **Grundfos** vakuutamme yksin vastuullisesti, että tuotteet **SQ** ja **SQE**, jota tämä vakuutus koskee, noudattavat direktiivejä jotka käsittelevät EY:n jäsenvaltioiden koneellisia laitteita koskevien lakien yhdenmukaista seur:

- Koneet (98/37/EY).
Käytetty standardi: EN ISO 12100.
- Elektromagneettinen vastaavuus (89/336/EY).
Käytetyt standardit: EN 55014-1, EN 55014-2, EN 61000-3-2 ja EN 61000-3-3.
- Määrättyjen jännitteenrajitusten puitteissa käytettävät sähköiset laitteet (73/23/EY) [95].
Käytetyt standardit: EN 60335-1: 1994 ja EN 60335-2-41: 1996.

(DK) Overensstemmelseerklæring

Vi **Grundfos** erklærer under ansvar, at produkterne **SQ** og **SQE**, som denne erklæring omhandler, er i overensstemmelse med Rådets direktiver om indbyrdes tilnærmelse til EF medlemsstaternes lovgivning om

- Maskiner (98/37/EF).
Anvendt standard: EN ISO 12100.
- Elektromagnetisk kompatibilitet (89/336/EØF).
Anvendte standarder: EN 55014-1, EN 55014-2, EN 61000-3-2 og EN 61000-3-3.
- Elektrisk materiel bestemt til anvendelse inden for visse spændingsgrænser (73/23/EØF) [95].
Anvendte standarder: EN 60335-1: 1994 og EN 60335-2-41: 1996.

(PL) Deklaracja zgodności

My, **Grundfos**, oświadczamy z pełną odpowiedzialnością, że nasze wyroby **SQ** oraz **SQE**, których deklaracja niniejsza dotyczy, są zgodne z następującymi wytycznymi Rady d/s ujednolicenia przepisów prawnych krajów członkowskich EG:

- maszyny (98/37/EG),
zastosowana norma: EN ISO 12100.
- zgodność elektromagnetyczna (89/336/EWG),
zastosowane normy: EN 55014-1, EN 55014-2, EN 61000-3-2 i EN 61000-3-3.
- wyposażenie elektryczne do stosowania w określonym zakresie napięć (73/23/EWG) [95],
zastosowane normy: EN 60335-1: 1994 i EN 60335-2-41: 1996.

(RU) Свидетельство о соответствии требованиям

Мы, фирма **Grundfos**, со всей ответственностью заявляем, что изделия **SQ** и **SQE**, к которым и относится данное свидетельство, отвечают требованиям следующих указаний Совета ЕС об унификации законодательных предписаний стран-членов ЕС:

- Машиностроение (98/37/ЕС).
Применяющиеся стандарты: Евростандарт EN ISO 12100.
- Электромагнитная совместимость (89/336/ЕЭС).
Применяющиеся стандарты: Евростандарт EN 55014-1, EN 55014-2, EN 61000-3-2 и EN 61000-3-3.
- Электрические машины для эксплуатации в пределах определенного диапазона значений напряжения (73/23/ЕЭС) [95].
Применяющиеся стандарты: Евростандарт EN 60335-1: 1994 и EN 60335-2-41: 1996.

(H) Konformitási nyilatkozat

Mi, a **Grundfos**, egyedüli felelősséggel kijelentjük, hogy az **SQ** és **SQE** termékek, amelyekre jelen nyilatkozat vonatkozik, megfelelnek az Európai Unió tagállamainak jogi irányelveit összehangoló tanács alábbi irányelveinek:

- Gépek (98/37/EK).
Alkalmazott szabvány: EN ISO 12100.
- Elektromágneses összeférhetőség (89/336/EGK).
Alkalmazott szabványok: EN 55014-1, EN 55014-2, EN 61000-3-2 és EN 61000-3-3.
- Meghatározott feszültség határokon belül használt elektromos eszközök (73/23/EGK) [95].
Alkalmazott szabványok: EN 60335-1: 1994 és EN 60335-2-41: 1996.

(SI) Izjava o ustreznosti

Mi, **Grundfos**, pod polno odgovornostjo izjavljamo, da so izdelki **SQ** in **SQE**, na katere se ta izjava nanaša, v skladu z naslednjimi smernicami Sveta za uskladitev pravnih predpisov držav članic Evropske skupnosti:

- Stroji (98/37/EG).
Uporabljena norma: EN ISO 12100.
- Elektromagnetna kompatibilnost (89/336/EWG).
Uporabljeni normi: EN 55014-1, EN 55014-2, EN 61000-3-2 in EN 61000-3-3.
- Električna pogonska sredstva za uporabo v določenih napetostnih mejah (73/23/EWG) [95].
Uporabljeni normi: EN 60335-1: 1994 in EN 60335-2-41: 1996.

(HR) Izjava o usklađenosti

Mi, **Grundfos**, izjavljujemo uz punu odgovornost, da su proizvodi **SQ** i **SQE**, na koje se ova izjava odnosi, sukladni smjernicama Savjeta za prilagodbu jedne država članica EZ:

- Strojevi (98/37/EZ).
Korištena norma: EN ISO 12100.
- Elektromagnetska kompatibilnost (89/336/EEZ).
Korištene norme: EN 55014-1, EN 55014-2, EN 61000-3-2 i EN 61000-3-3.
- Električni pogonski uređaji za korištenje unutar određenih granica napona (73/23/EEZ) [95].
Korištene norme: EN 60335-1: 1994 i EN 60335-2-41: 1996.

(YU) Izjava o konformitetu

Mi, **Grundfos**, izjavljujemo pod potpunom odgovornošću da su proizvodi **SQ** i **SQE** na koje se odnosi ova izjava u saglasnosti sa smernicama i uputstvima Saveta za usaglašavanje pravnih propisa članica Evropske unije:

- mašine (98/37/EG).
korišćen standard: EN ISO 12100.
- elektromagnetna usaglašenost (89/336/EWG).
korišćeni standardi: EN 55014-1, EN 55014-2, EN 61000-3-2 i EN 61000-3-3.
- električna oprema razvijena za korišćenje unutar određenih naponskih granica: (73/23/EWG) [95].
korišćeni standardi: EN 60335-1: 1994 i EN 60335-2-41: 1996.

(RO) Declarație de conformitate

Noi, **Grundfos**, declarăm asumându-ne întreaga responsabilitate că produsele **SQ**, **SQE** la care se referă această declarație sunt în conformitate cu Directivele Consiliului în ceea ce privește alinierea legislațiilor Statelor Membre ale CE, referitoare la:

- Utilaje (98/37/CE).
Standard aplicat: EN ISO 12100.
- Compatibilitate electromagnetică (89/336/CEE).
Standarde aplicate: EN 55014-1, EN 55014-2, EN 61000-3-2 și EN 61000-3-3.
- Echipamente electrice destinate utilizării între limite exacte de tensiune (73/23/CEE) [95].
Standarde aplicate: EN 60335-1: 1994 și EN 60335-2-41: 1996.

(BG) Декларация за съответствие

Ние, фирма **Grundfos** заявяваме с пълна отговорност, че продуктите **SQ** и **SQE**, за които се отнася настоящата декларация, отговарят на следните указания на Съвета за уеднаквяване на правните разпоредби на държавите членки на ЕО:

- Машины (98/37/ЕО).
Приложена норма: EN ISO 12100.
- Электромагнетична поносимост (89/336/ЕИО).
Приложени норми: EN 55014-1, EN 55014-2, EN 61000-3-2 и EN 61000-3-3.
- Електрически машини и съоръжения за употреба в рамките на определени граници на напрежение на електрическия ток (73/23/ЕИО) [95].
Приложени норми: EN 60335-1: 1994 и EN 60335-2-41: 1996.

(CZ) Prohlášení o konformitě

My firma **Grundfos** prohlašujeme na svou plnou odpovědnost, že výrobky **SQ** a **SQE** na něž se toto prohlášení vztahuje, jsou v souladu s ustanoveními směrnice Rady pro sblížení právních předpisů členských států Evropského společenství v oblastech:

- strojírenství (98/37/EG),
použitá norma: EN ISO 12100.
- elektromagnetická kompatibilita (89/336/EWG),
použité normy: EN 55014-1, EN 55014-2, EN 61000-3-2 a EN 61000-3-3.
- provozování spotřebičů v toleranci napětí (73/23/EWG) [95],
použité normy: EN 60335-1: 1994 a EN 60335-2-41: 1996.

(SK) Prehľadenie o konformite

My firma **Grundfos**, na svoju plnú zodpovednosť prehlasujeme, že výrobky **SQ, SQE**, na ktoré sa toto prehlásenie vzťahuje, sú v súlade s nasledovnými smernicami Rady pro zblíženie právnych predpisov členských zemi Európskej únie:

- Stroje (98/37/EG),
Použitá norma: EN ISO 12100.
- Elektromagnetická kompatibilita (89/336/EWG),
Použitie normy: EN 55014-1, EN 55014-2, EN 61000-3-2 a EN 61000-3-3.
- Elektrické prevádzkové prostriedky, použité v určitom napätovom rozsahu (73/23/EWG) [95],
Použitie normy: EN 60335-1: 1994 a EN 60335-2-41: 1996.

(TR) Uygunluk Bildirgesi

Biz **Grundfos** olarak, bu beyanda belirtilen **SQ** ve **SQE** ürünlerinin,

- Makina (98/37/EC),
Kullanilan standart: EN ISO 12100.
- Elektromanyetik uyumluluk (89/336/EEC),
Kullanilan standartlar: EN 55014-1, EN 55014-2, EN 61000-3-2 ve EN 61000-3-3.
- Belli voltaj sınırlarında kullanılmak üzere üretilmiş elektrik donanımı (73/23/EEC) [95].

Kullanilan standartlar: EN 60335-1: 1994 ve EN 60335-2-41: 1996.
ile ilgili olarak Avrupa topluluğu'na Üye Devletlerin yasalarında yer alan Belediye Yönetmeliklerine uygun olduğunu, tüm sorumluluğu bize ait olmak üzere beyan ederiz.

(EE) Vastavuse deklaratsioon

Meie **Grundfos** deklareerime enda ainuvastutusel, et toode **SQ** ja **SQE**, mille kohta käesolev juhend käib, on vastavuses EL nõukogu Direktiividega EMÜ liikmesriikide seaduste ühitamise kohta, mis käsitlevad:

- Masinad (98/37/EC),
Kasutatud standardid: EN ISO 12100.
- Elektromagnetilist õhulüüust (89/336/EEC),
Kasutatud standardid: EN 55014-1, EN 55014-2, EN 61000-3-2 ja EN 61000-3-3.
- Madalapinge-elektriseadmed (73/23/EEC) [95],
Kasutatud standardid: EN 60335-1: 1994 ja EN 60335-2-41: 1996.

(LT) Atitikties deklaracija

Mes, **Grundfos**, su visa atsakomybe pareiškiame, kad gaminiai **SQ** ir **SQE**, kuriems skirta ši deklaracija, atitinka Tarybos Direktyvas dėl Europos Ekonominės Bendrijos šalių narių įstatymų suderinimo šiose srityse:

- Mašinos (98/37/EC),
Naudojamas standartas: EN ISO 12100.
- Elektromagnetinis suderinamumas (89/336/EEC),
Naudojami standartai: EN 55014-1, EN 55014-2, EN 61000-3-2 ir EN 61000-3-3.
- Elektriniai prietaisai, skirti naudoti tam tikrose įtampų ribose (73/23/EEC) [95].
Naudojami standartai: EN 60335-1: 1994 ir EN 60335-2-41: 1996.

(LV) Paziņojums par atbilstību prasībām

Sabiedrība **Grundfos** ar pilnu atbildību dara zināmu, ka izstrādājumi **SQ** un **SQE**, uz kuriem attiecas šis paziņojums, atbilst šādām Padomes direktīvām par tuvināšanas EK dalībvalstu likumdošanas normām:

- Mašīnbūve (98/37/EK),
Piemērotais standarts: EN ISO 12100.
- Elektromagnētiskā savienojamība (89/336/EEK),
Piemērotie standarti: EN 55014-1, EN 55014-2, EN 61000-3-2 un EN 61000-3-3.
- Elektriskais aprīkojums, kas paredzēts lietošanai zināmu sprieguma robežvērtību ietvaros (73/23/EEK) [95],
Piemērotie standarti: EN 60335-1: 1994 un EN 60335-2-41: 1996.

Bjerringbro, 1st October 2005

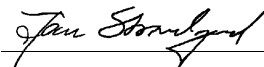

Jan Strandgaard
Technical Director

SQ, SQE

Installation and operating instructions	6	GB
Montage- und Betriebsanleitung	18	D
Notice d'installation et d'entretien	31	F
Istruzioni di installazione e funzionamento	43	I
Instrucciones de instalación y funcionamiento	55	E
Instruções de instalação e funcionamento	67	P
Οδηγίες εγκατάστασης και λειτουργίας	79	GR
Installatie- en bedieningsinstructies	91	NL
Monterings- och driftsinstruktion	103	S
Asennus- ja käyttöohjeet	114	FIN
Monterings- og driftsinstruktion	125	DK
Instrukcja montażu i eksploatacji	136	PL
Руководство по монтажу и эксплуатации	149	RU
Szerelési és üzemeltetési utasítás	163	H
Navodilo za montažo in obratovanje	176	SI
Montažne i pogonske upute	188	HR
Uputstvo za montažu i upotrebu	201	YU
Instrucțiuni de instalare și utilizare	214	RO
Упътване за монтаж и експлоатация	226	BG
Montážní a provozní návod	240	CZ
Návod na montáž a prevádzku	253	SK
Montaj ve kullanım kılavuzu	266	TR
Paigaldus- ja kasutusjuhend	280	EE
Montavimo ir eksploatacijos instrukcija	291	LT
Uzstādīšanas un ekspluatācijas instrukcija	303	LV

CONTENTS

GB

	Page
1. General	6
1.1 Applications	6
2. Technical data	7
2.1 Storage	7
2.2 Sound pressure level	7
3. Preparation	7
3.1 Refilling of motor liquid	7
3.2 Positional requirements	7
3.3 Liquid temperatures/cooling	8
4. Electrical connection	8
4.1 General	8
4.2 Motor protection	8
4.3 Connection of motor	9
5. Installation	9
5.1 General	9
5.2 Assembly of pump part and motor	9
5.3 Removal of non-return valve	9
5.4 Fitting the cable plug to the motor	9
5.5 Fitting the cable guard	10
5.6 Cable sizing	10
5.7 Fitting the submersible drop cable	11
5.8 Pipework connection	11
6. Start-up	12
7. Operation	12
7.1 Minimum flow rate	12
7.2 Selection of diaphragm tank and setting of precharge pressure and pressure switch	13
7.3 Built-in protection	14
8. Maintenance and service	14
8.1 Contaminated pumps	14
9. Fault finding chart	15
9.1 Megging	16
10. Checking the electricity supply	17
11. Environment	17
12. Disposal	17



Before beginning installation procedures, these installation and operating instructions should be studied carefully. The installation and operation should also be in accordance with local regulations and accepted codes of good practice.

1. General

On page 315 of these installation and operating instructions, you will find copies of the pump and motor nameplates.

Before the SQ/SQE pump is lowered into the borehole, this page should be filled in with the relevant nameplate data.

These installation and operating instructions must be kept in a dry place near the installation site for reference purposes.

1.1 Applications

The **SQ** and **SQE** pumps are designed for pumping thin, clean, non-aggressive, non-explosive liquids, not containing solid particles or fibres.

Typical applications:

- Groundwater supply for
 - private housing,
 - small waterworks,
 - irrigation systems in for instance green houses.
- Liquid transfer in tanks.
- Pressure boosting.

The **SQE-NE** pumps are designed for pumping thin, clean, non-explosive liquids, not containing solid particles or fibres.

These pumps are suitable for pumping contaminated or hydrogen-carbonate containing groundwater, e.g. from

- dumps,
- chemical depots,
- industrial areas,
- oil and petrol filling stations,
- environmental applications.

The **SQE-NE** pumps can also be used for sampling and monitoring and to some extent for incorporation in water treatment systems.

Information applying to all pump types:

The maximum sand content of the water must not exceed 50 g/m³. A larger sand content will reduce the life of the pump and increase the risk of blocking.

Note: If liquids with a viscosity higher than that of water are to be pumped, please contact Grundfos.

pH values:

SQ and SQE: 5 to 9.

SQE-NE: Please contact Grundfos.

Liquid temperature:

The temperature of the pumped liquid must not exceed 35°C.

2. Technical data

Supply voltage:

1 x 200-240 V $-10\%/+6\%$, 50/60 Hz, PE.

Operation via generator: As a minimum, the generator output must be equal to the motor P_1 [kW] + 10%.

Starting current:

The motor starting current is equal to the highest value stated on the motor nameplate.

Power factor:

PF = 1.

Motor liquid:

Type SML 2.

Motor cable:

1.5 m, 3 x 1.5 mm², PE.

Liquid temperature:

Maximum 35°C.

Pump outlet size:

SQ 1, SQ 2, SQ 3: Rp 1¼.
SQ 5, SQ 7: Rp 1½.

Pump diameter:

74 mm.

Borehole diameter:

Minimum 76 mm.

Installation depth:

Maximum 150 m below static water level.
See also section 5.8.2 *Installation depths*.

Net weight:

Maximum 6.5 kg.

2.1 Storage

Storage temperature: -20°C to $+60^{\circ}\text{C}$.

2.1.1 Frost protection

If the pump has to be stored after use, it must be stored on a frost-free location or it must be ensured that the motor liquid is frost-proof.

The motor must not be stored without being filled with motor liquid.

2.2 Sound pressure level

The sound pressure level of the pump is lower than the limiting values stated in the EC Council Directive 98/37/EC relating to machinery.

3. Preparation

Grundfos MS 3 and MSE 3 submersible motors have water-lubricated slide bearings. No additional lubrication is required.

The submersible motors are factory-filled with a special Grundfos motor liquid (type SML 2), which is frost-proof down to -20°C and preserved to prevent the growth of bacteria.

The level of motor liquid is decisive for the operating life of the bearings and consequently the life of the motor.

3.1 Refilling of motor liquid

If for any reason the motor liquid has been drained or lost, the motor must be refilled with Grundfos motor liquid SML 2.

To refill the motor, proceed as follows:

1. Remove the cable guard and separate the pump part from the motor.

Fig. 1

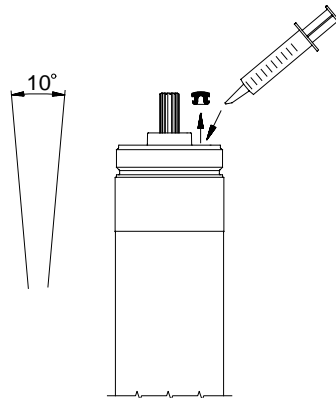

TM02 9606 3504

2. Place the motor in vertical position with an inclination of approx. 10° .
 3. Remove the filling plug using a screwdriver or a similar tool.
 4. Inject motor liquid into the motor with a filling syringe or the like.
 5. To allow possible air to escape, move the motor from side to side.
 6. Refit the filling plug and make sure it is tight.
 7. Assemble pump part and motor.
 8. Refit the cable guard.
- The pump is now ready for installation.

3.2 Positional requirements

The pump is suitable for vertical as well as horizontal installation, however, the pump shaft **must never** fall below the horizontal plane, see fig. 2.

Fig. 2

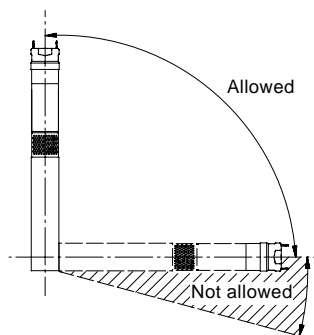

TM01 1375 4397

If the pump is to be installed horizontally, e.g. in a tank, and there is a risk that the pump might be covered by mud, it must be fitted in a flow sleeve.

For installation depths, see section 5.8.2.

3.3 Liquid temperatures/cooling

Figure 3 shows an SQ/SQE pump installed in a borehole. The pump is operating.

Figure 3 illustrates the following:

- Borehole diameter.
- Pump diameter.
- Temperature of pumped liquid.
- Flow past the motor to the pump suction strainer.

Fig. 3

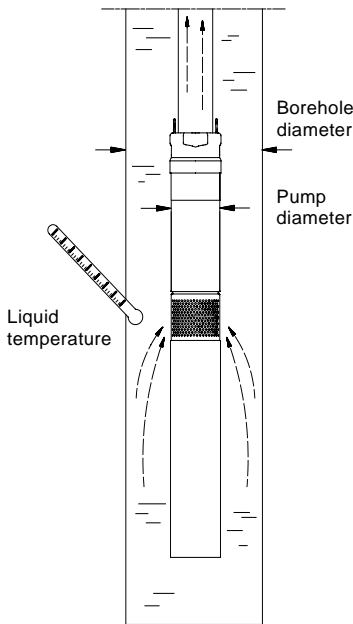

To ensure sufficient cooling of the motor, it is important to observe the maximum liquid temperature of 35°C under all conditions.

Note: The borehole diameter must be at least 76 mm (approx. 3").

The motor should always be installed above the well screen. If a flow sleeve is used, the pump may be installed freely in the borehole.

Note: Do not let the pump run against a closed discharge pipe for more than 5 minutes. When the discharge pipe is closed, there is no cooling flow and there is a risk of overtemperature in motor and pump.

If the actual temperature of the pumped liquid exceeds the specified value or the operating conditions otherwise fall outside the specified conditions, the pump may stop. Please contact Grundfos.

4. Electrical connection

4.1 General

The electrical connection should be carried out by an authorized electrician in accordance with local regulations.

Before starting work on the pump, make sure that the electricity supply has been switched off and that it cannot be accidentally switched on.

The pump must be earthed.



The pump must be connected to an external mains switch with a minimum contact gap of 3 mm in all poles.

If the motor cable is damaged, it must be replaced by Grundfos, an authorised Grundfos service workshop or similarly qualified persons to avoid a hazard.

The supply voltage, rated maximum current and power factor (PF) appear from the motor nameplate.

The required voltage for Grundfos submersible motors, measured at the motor terminals, is $-10\%/+6\%$ of the nominal voltage during continuous operation (including variation in the supply voltage and losses in cables).

If the pump is connected to an electric installation where an earth-leakage circuit breaker (ELCB) is used as an additional protection, this circuit breaker **must** trip out when earth fault currents with DC content (pulsating DC) occur.

The earth leakage circuit breaker **must** be marked with the following symbol: .

Supply voltage:

1 x 200-240 V $-10\%/+6\%$, 50/60 Hz, PE.

The current consumption can only be measured by means of a true RMS instrument. If other instruments are used, the value measured will differ from the actual value.

On SQ/SQE pumps, a leakage current of 2.5 mA at 230 V, 50 Hz, can typically be measured. The leakage current is proportional to the supply voltage.

The SQE and SQE-NE pumps can be connected to a control box, type CU 300 or CU 301.

Note: The pump must never be connected to a capacitor or to another type of control box than CU 300 or CU 301.

The pump must never be connected to an external frequency converter.

4.2 Motor protection

The motor incorporates thermal overload protection and requires no additional motor protection.

4.3 Connection of motor

The motor incorporates a starter device and can therefore be connected directly to the mains. Start/stop of the pump will typically be done via a pressure switch, see fig. 4.

Note: The pressure switch must be rated for the maximum amps of the specific pump size.

Fig. 4

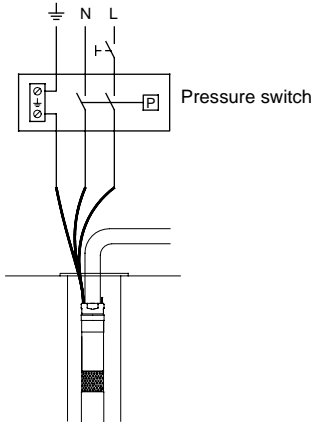

TM01 1480 4697

5. Installation

5.1 General



Before starting any work on the pump/motor, make sure that the electricity supply has been switched off and that it cannot be accidentally switched on.

Note: Do not lower or lift the pump by means of the motor cable.

The loose data plate supplied with the pump should be fixed close to the installation site.

5.2 Assembly of pump part and motor

To assemble pump part and motor, proceed as follows:

1. Place the motor horizontally in a vice and tighten it, see fig. 6.
2. Pull the pump shaft out to the position shown in fig. 5.

Fig. 5

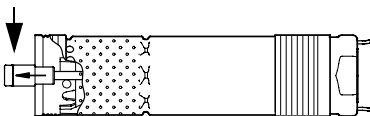

TM02 8425 5203

3. Grease the motor shaft end with the grease supplied with the motor.

4. Screw the pump part on the motor (55 Nm).

Note: The pump shaft must engage with the motor shaft.

A spanner may be used on the clamping faces of the pump part, see fig. 6.

Fig. 6

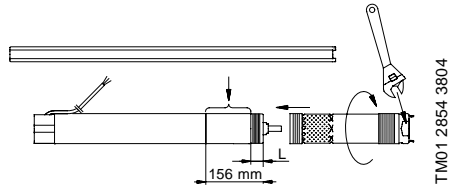

TM01 2854 3804

Motor (P2)	L
[kW]	[mm]
0.70	120
1.15	102
1.68	66
1.85	66

When pump part and motor have been assembled correctly, there must not be a clearance between pump part and motor.

5.3 Removal of non-return valve

If a pump without non-return valve is required, the valve can be removed as follows:

1. Cut off the legs of the valve guide using side-cutting pliers or a similar tool, see fig. 7.
2. Turn the pump upside down.
3. Check that all loose parts fall out of the pump.

Fig. 7

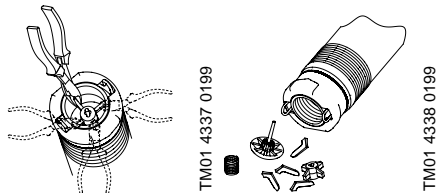

TM01 4337 0199

TM01 4338 0199

Note: SQE-NE is supplied without non-return valve.

The non-return valve can be fitted in a Grundfos service workshop.

5.4 Fitting the cable plug to the motor

The motor plug must under no circumstances be removed by the user.

The following description is exclusively intended for service personnel.



If the motor cable is to be replaced, see section 4.1 General.

The cable with plug must be fitted or removed by an authorised Grundfos service workshop or a similarly qualified person.

The cable plug supplied with the motor is factory-greased. Check that the plug is greased correctly.

To fit the cable plug, proceed as follows:

1. Check that the cable is of the correct type, cross-section and length.
2. Check that the mains on the location has correct connection to earth.
3. Check that the motor socket is clean and dry. Make sure that the loose gasket has been fitted.
4. Press the cable plug onto the motor socket. The plug cannot be fitted wrongly, see fig. 8.

Fig. 8

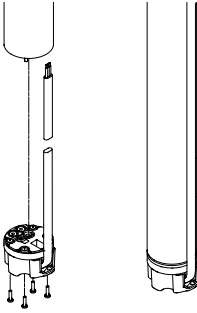

5. Fit and tighten the four screws (1-1.5 Nm), see fig. 8.

When the plug has been fitted, there must not be a clearance between the motor and the cable plug.

5.5 Fitting the cable guard

To fit the cable guard, proceed as follows:

1. Make sure that the submersible drop cable lies flat in the cable guard.
2. Place the cable guard in the groove in the cable plug. The two flaps of the cable guard must engage with the upper edge of the pump sleeve, see fig. 9.

Fig. 9

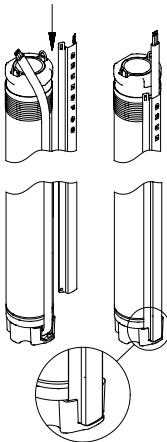

TM02 9605 3504

TM02 9613 3504

3. Fasten the cable guard to the pump suction strainer with the two self-tapping screws supplied, see fig. 10.

Fig. 10

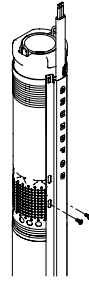

TM01 4427 0299

5.6 Cable sizing

Grundfos can supply submersible drop cables for any type of installation.

Note: The cross-section of the submersible drop cable must be large enough to meet the voltage requirements specified in section 4.1 *General*.

The table values below are calculated from the following formula:

$$q = \frac{I \times 2 \times 100 \times PF \times L \times \rho}{U \times \Delta U}$$

where

q = Cross-section of submersible drop cable [mm²].

I = Rated maximum current of the motor [A].

PF = 1.0.

L = Length of submersible drop cable [m].

ρ = Specific resistance: 0.02 [Ωmm²/m].

U = Nominal voltage [V].

ΔU = Voltage drop [%] = 4%.

The 4% voltage drop is according to IEC 3-64, HD-384 Series.

The calculation gives the following maximum cable lengths at a supply voltage of 240 V:

Motor (P2) [kW]	I_N [A]	Max. cable length [m]					
		Cable size					
		1.5 mm ²	2.1 mm ² / 14 AWG	2.5 mm ²	3.3 mm ² / 12 AWG	4 mm ²	6 mm ²
0.7	5.2	80	112	133	176	213	320
1.15	8.4	50	69	83	109	132	198
1.68	11.2	37	52	62	82	99	149
1.85	12	35	49	58	76	92	139

GB

5.7 Fitting the submersible drop cable

It is recommended to join the submersible drop cable and the motor cable by means of a Grundfos cable termination kit, type KM.

Cable termination kit, type KM	
Cross-sectional area	Product number
1.5 to 2.5 mm ²	96021462
4.0 to 6.0 mm ²	96021473

For larger cross-sections, please contact Grundfos.

5.8 Pipework connection

If a tool, e.g. a chain pipe wrench, is used when the riser pipe is fitted to the pump, the pump must only be gripped by the pump discharge chamber.

When connecting plastic pipes, a compression coupling should be used between the pump and the first pipe section.

Note: For pumps fitted with plastic pipes, the expansion of the pipes when loaded should be taken into consideration, when deciding on the installation depth of the pump.

Where flanged pipes are used, the flanges should be slotted to take the submersible drop cable.

Figure 11 shows a pump installation with indication of:

- position of cable clips, pos. 1, and distance between the clips.
- fitting of straining wire, pos. 2.
- maximum installation depth below the static water level.

Fig. 11

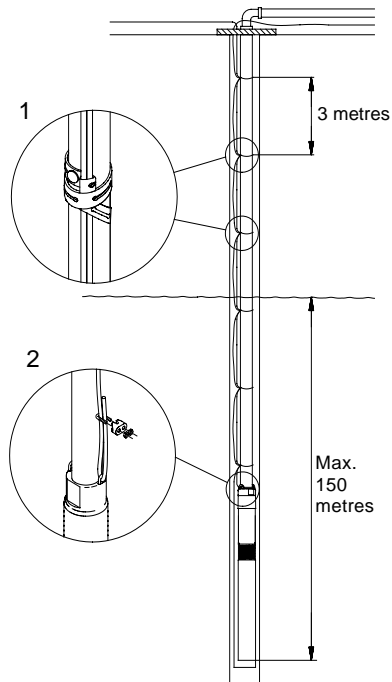

TM01 0480 4397

5.8.1 Cable clips

Cable clips must be fitted every 3 metres, see fig. 11.

When connecting plastic pipes, some slackness must be left between each cable clip as plastic pipes expand when loaded.

Where flanged pipes are used, the cable clips should be fitted above and below each joint.

5.8.2 Installation depths

Maximum installation depth below the static water level: 150 metres, see fig. 11.

Minimum installation depths below the dynamic water level:

- **Vertical installation:**
During start-up and operation, the pump must always be completely submerged in water.
- **Horizontal installation:**
The pump must be installed and run at least 0.5 metres below the dynamic water level.
If there is a risk that the pump might be covered by mud, the pump must always be fitted in a flow sleeve.

5.8.3 When lowering the pump into the borehole

It is recommended to secure the pump by an unloaded straining wire, see fig. 11, pos. 2.

Slacken the straining wire so that it becomes unloaded and lock it to the borehole seal by means of wire locks.

Note: The straining wire must not be used for pulling the pump with riser pipe out of the borehole.

Note: Do not lower or lift the pump by means of the motor cable.

6. Start-up

Make sure that the well is capable of yielding a minimum quantity of water corresponding to the pump capacity.

Do not start the pump until it is completely submerged in the liquid.

Start the pump and do not stop it until the pumped liquid is completely clean, as otherwise the pump parts and the non-return valve may choke up.

7. Operation

7.1 Minimum flow rate

To ensure the necessary cooling of the motor, the pump flow rate should never be set to a value lower than 50 l/h.

If the flow rate suddenly falls, the reason might be that the pump is pumping more water than the borehole can yield. The pump must be stopped and the fault corrected.

Note: The pump dry-running protection is effective only within the recommended duty range of the pump.

7.2 Selection of diaphragm tank and setting of precharge pressure and pressure switch



The installation must be designed for the maximum pump pressure.

As the pump has a built-in soft starter giving a run-up time of 2 seconds, the pressure at the pressure switch and diaphragm tank during starting will be lower than the pump cut-in pressure set on the pressure switch ($p_{\text{cut-in}}$). This lower pressure is called minimum pressure (p_{min}).

p_{min} is equal to the desired minimum pressure at the highest tap + head and head loss in the pipe from the pressure switch and diaphragm tank to the highest tap ($p_{\text{min}} = B + C$), see fig. 12.

Fig. 12

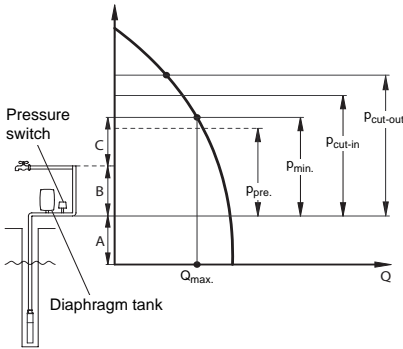

TM00 6445 3795

- A: Head + head loss from dynamic water level to diaphragm tank.
- B: Head + head loss from diaphragm tank to highest tap.
- C: Minimum pressure at highest tap.

Note: Make sure that the selected pump can deliver a pressure higher than $p_{\text{cut-out}} + A$.

p_{pre} : Precharge pressure of diaphragm tank.

p_{min} : Desired minimum pressure.

$p_{\text{cut-in}}$: Cut-in pressure set on pressure switch.

$p_{\text{cut-out}}$: Cut-out pressure set on pressure switch.

Q_{max} : Maximum flow at p_{min} .

Using p_{min} and Q_{max} , the **minimum** diaphragm tank size, precharge pressure and pressure switch settings can be found in the guideline table below:

Example:

$p_{\text{min}} = 35$ m head, $Q_{\text{max}} = 2.5$ m³/h.

On the basis of this information, the following values can be found in the table:

Minimum diaphragm tank size = 33 litres.

$p_{\text{pre}} = 31.5$ m head.

$p_{\text{cut-in}} = 36$ m head.

$p_{\text{cut-out}} = 50$ m head.

p_{min} [m]	Q_{max} [m ³ /h]																		p_{pre} [m]	$p_{\text{cut-in}}$ [m]	$p_{\text{cut-out}}$ [m]
	0.6	0.8	1	1.2	1.5	2	2.5	3	3.5	4	4.5	5	5.5	6	6.5	7	7.5	8			
Diaphragm tank size [litres]																					
25	8	8	18	18	18	18	24	33	33	50	50	50	50	80	80	80	80	80	22.5	26	40
30	8	8	18	18	18	24	33	33	50	50	50	50	80	80	80	80	80		27	31	45
35	8	18	18	18	18	24	33	33	50	50	50	80	80	80	80	80			31.5	36	50
40	8	18	18	18	18	24	33	50	50	50	80	80	80	80	80				36	41	55
45	8	18	18	18	24	33	33	50	50	50	80	80	80	80					40.5	46	60
50	8	18	18	18	24	33	50	50	50	80	80	80	80						45	51	65
55	18	18	18	18	24	33	50	50	50	80	80	80							49.5	56	70
60	18	18	18	18	24	33	50	50	80	80	80	80							54	61	75
65	18	18	18	24	24	33	50	50	80	80	80	80							58.5	66	80

1 m head = 0.098 bar.

7.3 Built-in protection

The motor incorporates an electronic unit which protects the motor in various situations.

In case of overload, the built-in overload protection will stop the pump for 5 minutes. After that period, the pump will attempt to restart.

If the pump has been stopped as a result of dry running, it will start automatically after 5 minutes.

If the pump is restarted and the borehole is empty, the pump will stop after 30 seconds.

Resetting of the pump: Switch off the electricity supply for 1 minute.

The motor is protected in case of:

- dry running,
- voltage surges (up to 6000 V),
In areas with high lightning intensity, external lightning protection is required.
- overvoltage,
- undervoltage,
- overload and
- overtemperature.

SQE pumps/MSE 3 motors:

Note: Via the CU 300 or CU 301, the dry-running stop limit of the MSE 3 motors can be adjusted to match the actual application.

8. Maintenance and service

The pumps are normally maintenance-free.

Deposits and wear may occur. For that purpose, service kits and service tools are available from Grundfos. The Grundfos Service Manual is available on request.

The pumps can be serviced at a Grundfos service centre.

8.1 Contaminated pumps

Note: If a pump has been used for a liquid which is injurious to health or toxic, the pump will be classified as contaminated.

If Grundfos is requested to service the pump, Grundfos must be contacted with details about the pumped liquid, etc. *before* the pump is returned for service. Otherwise Grundfos can refuse to accept the pump for service.

However, any application for service (no matter to whom it may be made) must include details about the pumped liquid if the pump has been used for liquids which are injurious to health or toxic.

SQE-NE: Only pumps that can be certified as uncontaminated, i.e. pumps containing no hazardous and/or toxic material, may be returned to Grundfos for servicing.

To prevent injury to the health of persons involved and to the environment, a document certifying that the pump is clean is required.

Grundfos must receive this certificate before the product. Otherwise, Grundfos will refuse to accept the product for servicing.

Possible costs of returning the pump are paid by the customer.

9. Fault finding chart



Before starting any work on the pump/motor, make sure that the electricity supply has been switched off and that it cannot be accidentally switched on.

GB

Fault	Cause	Remedy
1. The pump does not run.	a) The fuses in the electric installation are blown.	Replace the blown fuses. If the new ones blow too, the electric installation and the submersible drop cable should be checked.
	b) The ELCB or the voltage-operated ELCB has tripped out.	Cut in the circuit breaker.
	c) No electricity supply.	Contact the electricity supply authorities.
	d) The motor protection has cut off the electricity supply due to overload.	Check whether the motor/pump is blocked.
	e) The pump/submersible drop cable is defective.	Repair/replace the pump/cable.
	f) Overvoltage or undervoltage has occurred.	Check the electricity supply.
2. The pump runs but gives no water.	a) The discharge valve is closed.	Open the valve.
	b) No water or too low water level in borehole.	See item 3 a).
	c) The non-return valve is stuck in its closed position.	Pull out the pump and clean or replace the valve.
	d) The suction strainer is choked up.	Pull out the pump and clean the strainer.
	e) The pump is defective.	Repair/replace the pump.
3. The pump runs at reduced capacity.	a) The drawdown is larger than anticipated.	Increase the installation depth of the pump, throttle the pump or replace it by a smaller model to obtain a smaller capacity.
	b) The valves in the discharge pipe are partly closed/blocked.	Check and clean/replace the valves, if necessary.
	c) The discharge pipe is partly choked by impurities (ochre).	Clean/replace the discharge pipe.
	d) The non-return valve of the pump is partly blocked.	Pull out the pump and check/replace the valve.
	e) The pump and the riser pipe are partly choked by impurities (ochre).	Pull out the pump. Check and clean or replace the pump, if necessary. Clean the pipes.
	f) The pump is defective.	Repair/replace the pump.
	g) Leakage in the pipework.	Check and repair the pipework.
	h) The riser pipe is defective.	Replace the riser pipe.
	i) Undervoltage has occurred.	Check the electricity supply.

Fault	Cause	Remedy
4. Frequent starts and stops.	a) The differential of the pressure switch between the start and stop pressures is too small.	Increase the differential. However, the stop pressure must not exceed the operating pressure of the pressure tank, and the start pressure should be high enough to ensure sufficient water supply.
	b) The water level electrodes or level switches in the reservoir have not been installed correctly.	Adjust the intervals of the electrodes/level switches to ensure suitable time between the cutting-in and cutting-out of the pump. See installation and operating instructions for the automatic devices used. If the intervals between stop/start cannot be changed via the automatics, the pump capacity may be reduced by throttling the discharge valve.
	c) The non-return valve is leaking or stuck half-open.	Pull out the pump and clean/replace the non-return valve.
	d) The supply voltage is unstable.	Check the electricity supply.
	e) The motor temperature gets too high.	Check the water temperature.

9.1 Megging

Megging of an installation incorporating SQ/SQE pumps is not allowed, as the built-in electronics may be damaged, see fig. 13.

Fig. 13

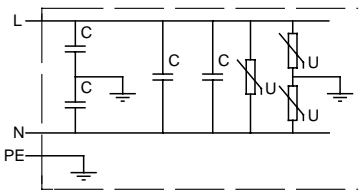

TM02 0689 5000

10. Checking the electricity supply



Before starting any work on the pump/motor, make sure that the electricity supply has been switched off and that it cannot be accidentally switched on.

GB

1. Supply voltage

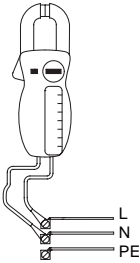

TM00 1371 4904

Measure the voltage (RMS) between phase and neutral. Connect the voltmeter to the terminals at the connection.

The voltage should, when the motor is loaded, be within the range specified in section 4. *Electrical connection*.

Large variations in supply voltage indicate poor electricity supply, and the pump should be stopped until the defect has been remedied.

2. Current consumption

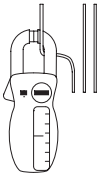

TM00 1372 5082

Measure the current (RMS) while the pump is operating at a constant discharge head (if possible, at the capacity where the motor is most heavily loaded).

For maximum current, see nameplate.

If the current exceeds the full load current, there are the following possible faults:

- Poor connection in leads, possibly in the cable joint.
- Too low supply voltage, see item 1.

11. Environment

During handling, operation, storage and transport, all environment regulations dealing with the handling of hazardous materials must be observed.



When the pump is taken out of operation, it must be ensured that no hazardous material is left in the pump/motor and the riser pipe, which can be injurious to persons and the environment.





In case of doubt, please contact Grundfos or the local authorities.





12. Disposal

Disposal of this product or parts of it must be carried out according to the following guidelines:

1. Use the local public or private waste collection service.
2. In case such waste collection service does not exist or cannot handle the materials used in the product, please deliver the product or any hazardous materials from it to your nearest Grundfos company or service workshop.

Nameplates to be filled in

	
PROD.NO. _____ MODEL B P1 _____	
U: _____ 50/60 Hz I: _____ A SINGLE PHASE	
P1: _____ kW P2: _____ kW S1/35 °C IEC/EN 60034 CI.1	
P2: _____ HP SF _____ FLA _____ LRA _____	
Ins Cl F PF 1.0 RPM: 10700 Weight 3.2 / 7 kg/lb IP 68 $\frac{\nabla}{150m}$ MADE IN DENMARK   	

	
PROD.NO. _____ MODEL _____ P1 _____ SQ/SQE _____	
Q: _____ m ³ /h	H: _____ m
Stages: _____ P2 motor _____ kW	
Weight _____ kg MADE IN DENMARK   	
Rp _____	

TM03 1353 1705

Denmark

GRUNDFOS DK A/S
Martin Bachs Vej 3
DK-8850 Bjerringbro
Tlf.: +45-87 50 50 50
Telefax: +45-87 50 51 51
E-mail: info_GDK@grundfos.com
www.grundfos.com/DK

Albania

COALB sh.p.k.
Rr.Dervish Hekall N.1
Al-Tirana
Phone: +355 42 22727
Telefax: +355 42 22727

Argentina

Bombas GRUNDFOS de Argentina S.A.
Ruta Panamericana km. 37.500 Lote 34A
1619 - Garn
Pcia. de Buenos Aires
Phone: +54-3327 414 444
Telefax: +54-3327 411 111

Australia

GRUNDFOS Pumps Pty. Ltd.
P.O. Box 2040
Regency Park
South Australia 5942
Phone: +61-8-8461-4611
Telefax: +61-8-8340 0155

Austria

GRUNDFOS Pumpen Vertrieb Ges.m.b.H.
Grundfosstraße 2
A-5082 Grödig/Salzburg
Tel.: +43-6246-883-0
Telefax: +43-6246-883-30

Belgium

N.V. GRUNDFOS Bellux S.A.
Boomsmaestweg 81-83
B-2630 Aartselaar
Tél.: +32-3-870 7300
Télécoipe: +32-3-870 7301

Belorussia

Представительство ГРУНДФОС в Минске
220090 Минск ул.Олеусаева 14
Телефон: (8632) 62-40-49
Факс: (8632) 62-40-49

Bosnia/Herzegovina

GRUNDFOS Sarajevo
Paromlinska br. 16,
BIH-71000 Sarajevo
Phone: +387 33 713290
Telefax: +387 33 231795

Brazil

GRUNDFOS do Brasil Ltda.
Rua Tomazina 106
CEP 83325 - 040
Pinhais - PR
Phone: +55-41 668 3555
Telefax: +55-41 668 3554

Bulgaria

GRUNDFOS Pumpen Vertrieb
Representative Office - Bulgaria
Bulgaria, 1421 Sofia
Lozenetz District
105-107 Arsenalski blvd.
Phone: +359 2963 3820, 2963 5653
Telefax: +359 2963 1305

Canada

GRUNDFOS Canada Inc.
2941 Brighton Road
Oakville, Ontario
L8H 6C9
Phone: +1-905 829 9533
Telefax: +1-905 829 9512

China

GRUNDFOS Pumps (Shanghai) Co. Ltd.
22 Floor, Xin Hua Lian Building
755-775 Huai Hai Rd. (W)
Shanghai 200020
PRC
Phone: +86-512-67 61 11 80
Telefax: +86-512-67 61 81 67

Croatia

GRUNDFOS predstavništvo Zagreb
Radoslava Cimermana 64a
HR-10000 Zagreb
Phone: +385 1 6595 400
Telefax: +385 1 6595 499

Czech Republic

GRUNDFOS s.r.o.
Čajkovského 21
779 00 Olomouc
Phone: +420-585-716 111
Telefax: +420-585-438 906

Estonia

GRUNDFOS Pumps Eesti OÜ
Petriburi tee 44
11-11 Tallinn
Tel: + 372 606 1690
Fax: + 372 606 1691

Finland

OY GRUNDFOS Pumpat AB
Mestarintie 11
Piispankylä
FIN-01730 Vantaa (Helsinki)
Phone: +358-9 879 9150
Telefax: +358-9 879 91550

France

Pompes GRUNDFOS Distribution S.A.
Parc d'Activités de Chesnes
57, rue de Malacombes
F-38290 St. Quentin Fallavier (Lyon)
Tél.: +33-4 72 82 15 15
Télécoipe: +33-4 74 94 10 51

Germany

GRUNDFOS GMBH
Schlüterstr. 33
40699 Erkrath
Tel.: +49-(0) 211 929 69-0
Telefax: +49-(0) 211 929 69-3799
e-mail: info@grundfos.de
Service in Deutschland:
e-mail: kundendienst@grundfos.de

Greece

GRUNDFOS Hellas A.E.B.E.
20th km. Athinon-Markopoulou Av.
P.O. Box 71
GR-19002 Peania
Phone: +0030-210-66 83 400
Telefax: +0030-210-66 46 273

Hong Kong

GRUNDFOS Pumps (Hong Kong) Ltd.
Unit 1, Ground floor
Siu Wai Industrial Centre
29-33 Wing Hong Street &
68 King Lam Street, Cheung Sha Wan
Kowloon
Phone: +852-27861706/27861741
Telefax: +852-27858664

Hungary

GRUNDFOS Hungária Kft.
Park u. 8
H-2045 Törökbalánt,
Phone: +36-23 511 110
Telefax: +36-23 511 111

India

GRUNDFOS Pumps India Private Limited
Flat A, Ground Floor
61/62 Chamiers Aptmt
Chamiers Road
Chennai 600 028
Phone: +91-44 432 3487
Telefax: +91-44 432 3489

Indonesia

PT GRUNDFOS Pompa
Jl. Rawa Sumur III, Blok III / CC-1
Kawasan Industri, Pulogadung
Jakarta 13930
Phone: +62-21-460 6909
Telefax: +62-21-460 6910/460 6901

Ireland

GRUNDFOS (Ireland) Ltd.
Unit 34, Stillorgan Industrial Park
Blackrock
County Dublin
Phone: +353-1-2954926
Telefax: +353-1-2954739

Italy

GRUNDFOS Pompe Italia S.r.l.
Via Gran Sasso 4
I-20060 Truccazzano (Milano)
Tel.: +39-02-95838112
Telefax: +39-02-95309290/95838461

Japan

GRUNDFOS Pumps K.K.
1-2-3, Shin Miyakoda
Hamamatsu City
Shizuoka pref. 431-21
Phone: +81-53-428 4760
Telefax: +81-53-484 1014

Korea

GRUNDFOS Pumps Korea Ltd.
6th Floor, Aju Building 679-5
Yeoksam-dong, Kangnam-ku, 135-916
Seoul, Korea
Phone: +82-2-5317 600
Telefax: +82-2-5633 725

Latvia

SIA GRUNDFOS Pumps Latvia
Deglava biznesa centrs
Augusta Deglava iela 60, LV-1035, Rīga,
Tālr.: + 371 714 9640, 7 149 641
Fakss: + 371 914 9646

Lithuania

GRUNDFOS Pumps UAB
Smolenko g. 6
LT-2600 Vilnius
Tel: + 370 52 395 430
Fax: + 370 52 395 431

Macedonia

MAKOTERM
Dame Grujev Streetje
MK-91000 Skopje
Phone: +389 91 117733
Telefax: +389 91 220100

Malaysia

GRUNDFOS Pumps Sdn. Bhd.
7 Jalan Peguam U1/25
Glenmarie Industrial Park
40150 Shah Alam
Selangor
Phone: +60-3-5569 2922
Telefax: +60-3-5569 2866

Mexico

Bombas GRUNDFOS de Mexico S.A. de
C.V.
Boulevard TlC No. 15
Parque Industrial Stiva Aeroportuo
Apoquia, N.L. 66600
Mexico
Phone: +52-81-8144 4000
Telefax: +52-81-8144 4010

Netherlands

GRUNDFOS Nederland B.V.
Postbus 104
NL-1380 AC Weesp
Tel.: +31-294-492 211
Telefax: +31-294-492244/492299

New Zealand

GRUNDFOS Pumps NZ Ltd.
17 Beatrice Tinsley Crescent
North Harbour Industrial Estate
Albany, Auckland
Phone: +64-9-415 3240
Telefax: +64-9-415 3250

Norway

GRUNDFOS Pumper A/S
Strømsveien 344
Postboks 235, Leirdal
N-1011 Oslo
Tlf.: +47-22 90 47 00
Telefax: +47-22 32 21 50

Poland

GRUNDFOS Pompy Sp. z o.o.
ul. Klonowa 23
Baranow k. Poznania
PL-62-081 Przeźmierowo
Phone: (+48-61) 650 13 00
Telefax: (+48-61) 650 13 50

Portugal

Bombas GRUNDFOS Portugal, S.A.
Rua Calvet de Magalhães, 241
Apartado 1079
P-2770-163 Paço de Arcos
Tel.: +351-21-440 76 00
Telefax: +351-21-440 76 90

Republic of Moldova

MOLDOCON S.R.L.
Bd. Dacia 401
MD-277062 Chishinau
Phone: +373 2 542530
Telefax: +373 2 542531

Romania

GRUNDFOS Pompa România SRL
Sos. Panduri No. 81-83, Sector 5
RO-050657 Bucharest
Phone: +40 21 4115460/4115461
Telefax: +40 21 4115462
E-mail: romanai@grundfos.ro

Russia

ООО Грундфос
Россия, 109544 Москва, Школьная 39
Тел. (+7) 995 737 30 00, 564 88 00
Факс (+7) 995 737 75 36, 564 88 11
E-mail grundfos.moscow@grundfos.com

Serbia and Montenegro

GRUNDFOS Predstavništvo Beograd
Dr. Milutina Ivkovića 2a/29
YU-11000 Beograd
Phone: +381 11 26 47 877, 11 26 47 496
Telefax: +381 11 26 48 340

Singapore

GRUNDFOS (Singapore) Pte. Ltd.
24 Tuas West Road
Jurong Town
Singapore 638381
Phone: +65-6865 1222
Telefax: +65-6861 8402

Slovenia

GRUNDFOS PUMPEN VERTRIEB
Ges.m.b.H.,
Podružnica Ljubljana
Blatnica 1, SI-126 Trzin
Phone: +386 1 563 5338
Telefax: +386 1 563 2098
E-mail: slovenia@grundfos.si

Spain

Bombas GRUNDFOS España S.A.
Camino de la Fuenteclita, s/n
E-28110 Algete (Madrid)
Tel.: +34-91-848 8800
Telefax: +34-91-628 0465

Sweden

GRUNDFOS AB
Lunnagårdsgatan 6
431 90 Mölndal
Tel.: +46-0771-32 23 00
Telefax: +46-31 331 94 80

Switzerland

GRUNDFOS Pumpen AG
Bruggacherstrasse 10
CH-8117 Fällanden/ZH
Tel.: +41-1-806 8111
Telefax: +41-1-806 8115

Taiwan

GRUNDFOS Pumps (Taiwan) Ltd.
7 Floor, 219 Min-Chuan Road
Taichung, Taiwan, R.O.C.
Phone: +886-4-2305 0868
Telefax: +886-4-2305 0878

Thailand

GRUNDFOS (Thailand) Ltd.
947/168 Moo 12, Bangna-Trad Rd., K.M. 3,
Bangka, Phrakonong
Bangkok 10260
Phone: +66-2-744 1785 ... 91
Telefax: +66-2-744 1775 ... 6

Turkey

GRUNDFOS POMPA San. ve Tic. Ltd. Sti.
Gebze Organize Sanayi Bölgesi
İhsan dede Caddesi,
2. yol 200, Sokak No. 204
41490 Gebze/Kocaeli
Phone: +90 - 262-679 7979
Telefax: +90 - 262-679 7905
E-mail: satis@grundfos.com

Ukraine

ГРУНДФОС Україна
ул. Владимирская, 71, оф. 45
г. Киев, 01033, Украина,
Тел. +380 44 289 4050
Факс +380 44 289 4139

United Arab Emirates

GRUNDFOS Gulf Distribution
P.O. Box 16768
Jebel Ali Free Zone
Dubai
Phone: +971-4- 8815 166
Telefax: +971-4-8815 136

United Kingdom

GRUNDFOS Pumps Ltd.
Grovebury Road
Leighton Buzzard/Beds. LU7 8TL
Phone: +44-1525-850000
Telefax: +44-1525-850011

U.S.A.

GRUNDFOS Pumps Corporation
17100 West 118th Terrace
Olathe, Kansas 66061
Phone: +1-913-227-3400
Telefax: +1-913-227-3500

Uzbekistan

Представительство ГРУНДФОС в
Ташкенте
700000 Ташкент ул.Усмана Носира 1-й
тулик 5
Телефон: (3712) 55-68-15
Факс: (3712) 53-36-35

96160909 1105	104
Repl. 96160909 1104 96030148 0604	