



SPX40 High Performance Hose Pumps

Features and Benefits

- Can run dry continuously
- Most suitable for handling shear sensitive products
- Accurate (+1%) dosing (metering) capabilities
- Smooth liquid passage without valves, dead corners, or glands
- The material to be pumped does not contact mechanical parts of seals
- Easy maintenance, low cost, short down time
- Only one wearing part: the hose
- Easily and completely cleanable
- Easily adjustable and reversible rotation
- Suitable for high viscosity and densities
- No metal contact or valves
- Safe for use in explosive environments
- No internal back flow (slip)
- Designed to pump liquids containing particles (abrasion is no restriction)
- Self priming to 95% vacuum
- Patented direct coupled design with rotor-supporting twin-bearing hub integrated into the pump-head and unique buffer zone to provide protective barrier between pumphead and gearmotor
- Ultra compact footprint with flanged planetary gearing: no coupling or drive alignment required
- Two year comprehensive warranty

Performance Chart

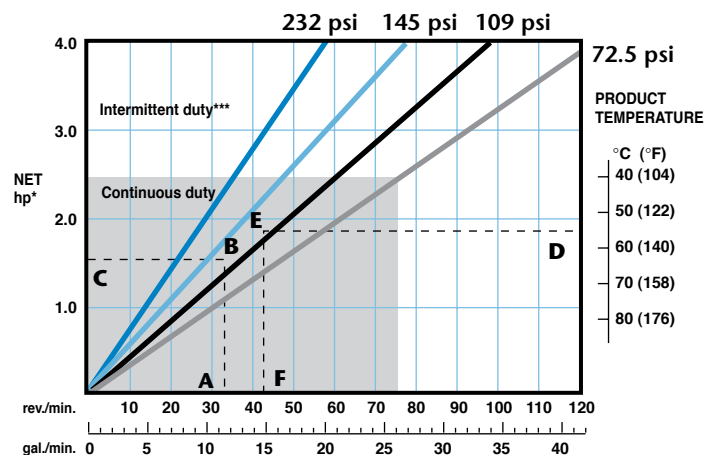

How to calculate speed/horsepower

- A** Flow required, indicates pump speed
- B** Calculated discharge pressure
- C** Horsepower required
- D** Fluid temperature
- E** Calculated discharge pressure
- F** Maximum recommended pump speed**

* Minimum starting torque 2,835 lbs based on starting unloaded at atmospheric discharge pressure. Starting torque can be 2-3X running torque if starting under the load of higher discharge pressures.
 ** For maximum hose life, speed point (A) should be lower than temperature adjusted speed point (F). See example points (A) thru (F). ***Intermittent duty = 2 hrs max continuous running, 1 hr stop before restart.

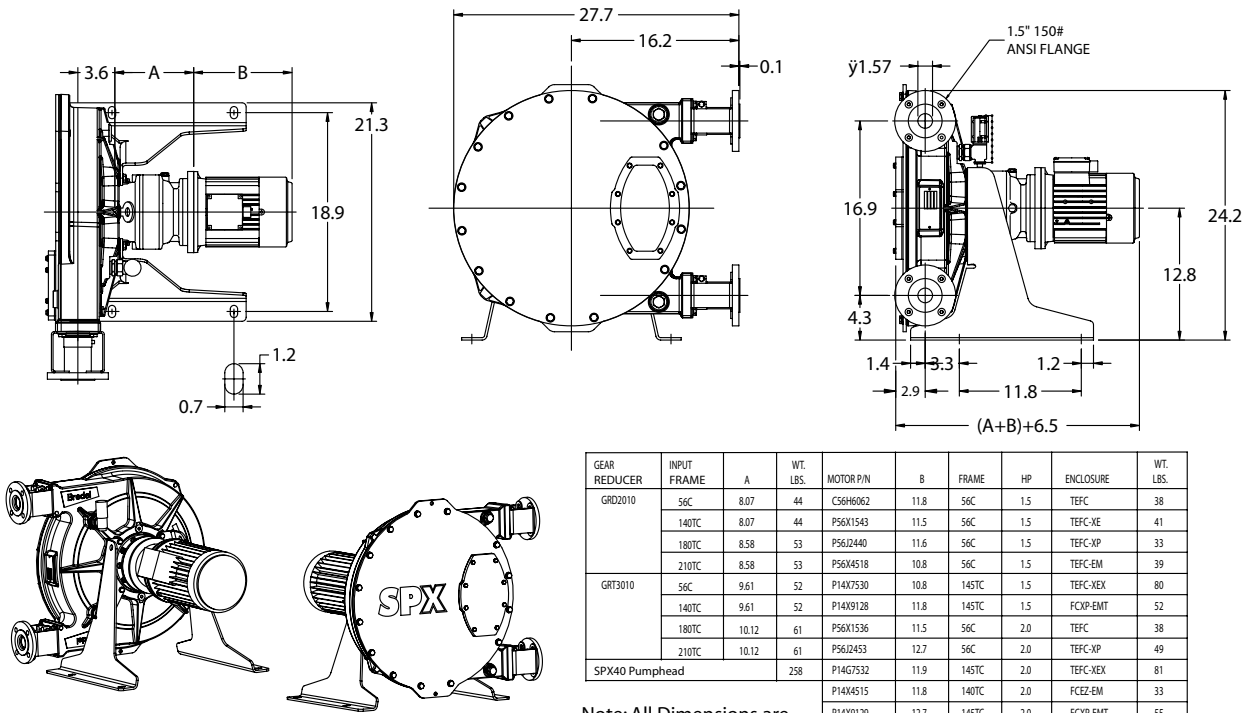

GEAR REDUCER	INPUT FRAME	A	WT. LBS.	MOTOR P/N	B	FRAME	HP	ENCLOSURE	WT. LBS.
GRD2010	56C	8.07	44	CS6H6062	11.8	56C	1.5	TEFC	38
	140TC	8.07	44	P56X1543	11.5	56C	1.5	TEFC-XE	41
	180TC	8.58	53	P56J2440	11.6	56C	1.5	TEFC-XP	33
	210TC	8.58	53	P56K4518	10.8	56C	1.5	TEFC-EM	39
GRT3010	56C	9.61	52	P14X7530	10.8	145TC	1.5	TEFC-XEX	80
	140TC	9.61	52	P14X9128	11.8	145TC	1.5	FCXP-EMT	52
	180TC	10.12	61	P56K1536	11.5	56C	2.0	TEFC	38
	210TC	10.12	61	P56J2453	12.7	56C	2.0	TEFC-XP	49
SPX40 Pumphead			258	P14G7532	11.9	145TC	2.0	TEFC-XEX	81
				P14K4515	11.8	140TC	2.0	FCZE-EM	33
				P14X9129	12.7	145TC	2.0	FCXP-EMT	55
				P18G1132	14.5	182TC	3.0	TEFC-XE	118
				P14B051	13.6	182TC	3.0	FCZE-EM	118
				P14X3049	12.8	140TC	3.0	TEFC-XP	50
				P18G1123	14.5	182TC	3.0	TEFC-XEX	125
				P18G1133	14.5	184TC	5.0	TEFC-XE	120
				P18G1051	15.3	184TC	5.0	FCXP	125
				P18G3864	13.8	184TC	5.0	FCZE-EM+	135
				P18G1124	14.5	184TC	5.0	TEFC-XEX	125

Note: All Dimensions are for Reference Only. Consult Watson Marlow Bredel for additional motor options. Mounting Position 2 shown. All Dimensions are in inches.

SPX40 High Performance Hose Pumps

Technical Specifications

Displacement: 0.351 gal/rev
Supply: 115/230VAC 1-phase or 230/460 or 575VAC 3-phase
Operating Speeds: Up to 75 rpm continuous
Up to 110 rpm intermittent
Fluid Temperature Range*: 14° to 176°F
Ambient Temperature Range:** -4° to 113°F
Hose Lubricant Required: 1.3 gallons
Flow Range: Up to 39 gpm
Discharge Pressure: Up to 232 psi
Suction Pressure: 28 ft. lift to 45 psi
Hose Materials: Natural Rubber, Buna N, EPDM, Hypalon, Bioprene***
Fittings: 1.5" 150# Flange
Insert Materials: 316SS, Polypropylene, PVC, PVDF
Optional High Level Hose Leak Sensor: NO or NC:
1A max, 250V max, 50VA max

When installing, allow min 44" linear clearance from ports to facilitate hose changing

Materials of Construction

Pumphead: Cast iron
Bearing Hub: Cast iron
Shims: 316SS
Flanges and Flange Brackets: Galvanized steel, 304SS or 316SS
Support Frame: Galvanized steel, 304SS or 316SS
Hardware: Zinc plated steel or 316SS
Hose Clamps: 304SS
Shaft: Alloy steel
Seals: Buna

*Consult Watson-Marlow Bredel for lower or higher temperature operation

**Allowable ambient temperature is based on pump capabilities and may be further limited by gearmotor ambient capabilities.

***Please contact Watson-Marlow Bredel Pumps Application Engineering for sizing.

The information contained in this document is believed to be correct, but Watson-Marlow/Bredel Pumps accepts no liability for any errors it contains, and reserves the right to alter specifications without notice.

Watson-Marlow Bredel Pumps

37 UPTON TECHNOLOGY PARK, WILMINGTON, MA 01887-1018
TEL: 800-282-8823, 978-658-6168 / FAX: 978-658-0041
<http://www.watson-marlow.com>