

Service instructions



SPK 1, SPK 2 and SPK 4 Model C and D

50 Hz	1/3~
60 Hz	3~

Table of contents

1.	Type identification	2
1.1	Nameplate	2
1.2	Type key	3
2.	Torques and lubricants	4
3.	Shaft seals	4
4.	Service tools	5
4.1	Special tools	5
4.2	Standard tools	5
4.3	Torque tools	5
5.	Dismantling and assembly	6
5.1	General information	6
5.2	Dismantling	6
5.3	Assembly	8
6.	Order of assembly for chambers and impellers	10
6.1	Stage survey	10
6.2	Symbol survey	13

1. Type identification

This section shows the nameplate, the type key and the codes that can appear in the variant code.

1.1 Nameplate

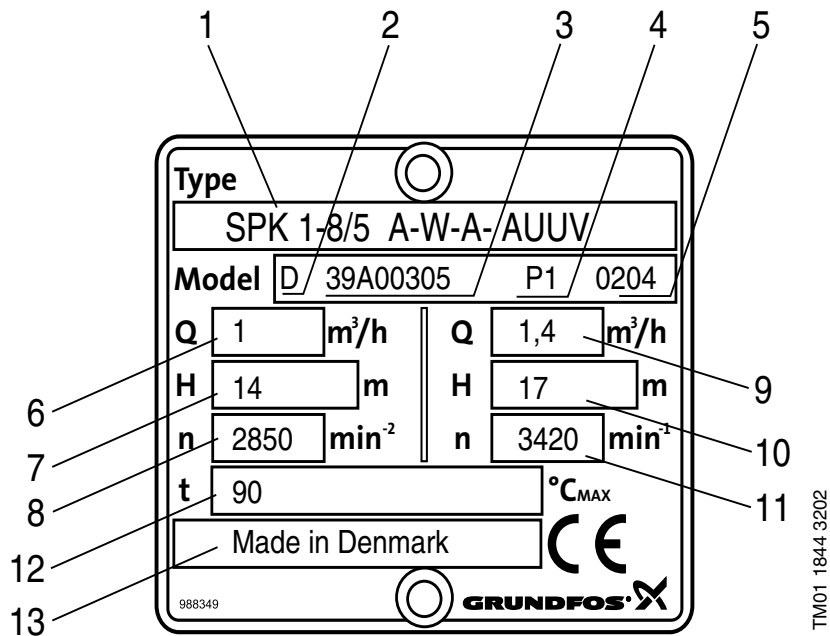

Pos.	Description	Pos.	Description
1	Type designation, see section 1.2 Type key	8	Speed, 50 Hz
2	Model	9	Rated flow rate, 60 Hz
3	Product number	10	Head at rated flow rate, 60 Hz
4	Place of production	11	Speed, 60 Hz
5	Production year and week	12	Max. temperature
6	Rated flow rate, 50 Hz	13	Country of production
7	Head at rated flow rate, 50 Hz		

1.2 Type key

Example	SP	K	1 -	8	/5	X -	X -	X -	X -	XXXX
Type range										
Cooling lubricant / condensate										
Nominal flow rate m ³ /h, 50 Hz										
Number of stages										
Number of impellers (only used if the pump has fewer impellers than chambers)										
Code for special product										
Code for pump version: A = Basic L = With extension pipe										
Code for pipework connection W = Internal thread										
Code for materials: A = Basic version: Pump head: Cast iron Other wetted parts: Stainless steel DIN W.-Nr. 1.4301, AISI 304 I = Pump head and other wetted parts: Stainless steel DIN W.-Nr. 1.4401, 1.4408, AISI 316 or 316LN										
Code for shaft seal: CVBV = O-ring seal; rotating face: aluminium oxide; stationary seat: synthetic resin-impregnated carbon; O-rings: FKM AUUV = O-ring seal; rotating face: tungsten carbide; stationary seat: tungsten carbide; O-rings: FKM										

2. Torques and lubricants

This section shows the screws and nuts that must be tightened to a certain torque and the lubricants to be used.

Pos.	Description	Dim.	Torque [Nm]	Lubricant
9	Screw	M6 x 20	13	Thread-Eze
28	Screw	M5 x 20	5	
		M6 x 20		
36	Nut	M8	18	Gardolube
67	Lock nut	M8	12	
84b	Screw	M4	2	

Thread-Eze, part no. SV9997 (0.5 l).

Gardolube L 6034, part no. SV9995 (1 l).

3. Shaft seals

Example:

SPK	C	A CVBV	1
	D	AUUV	2

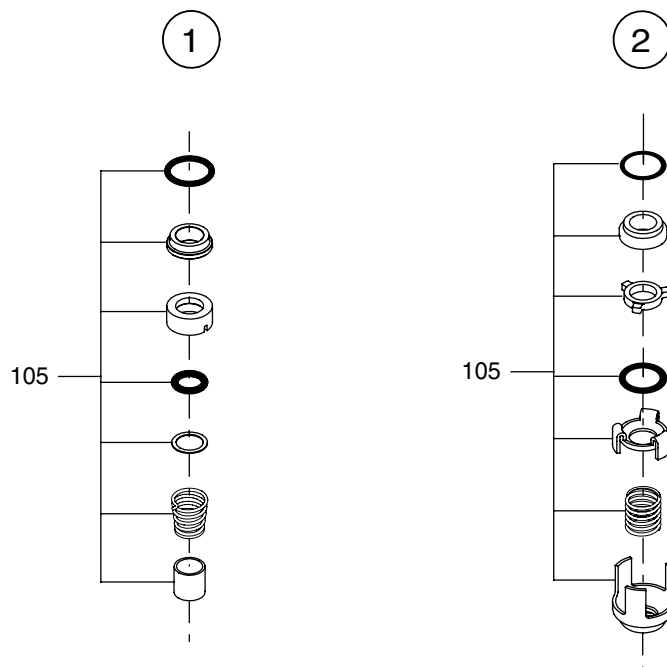

TM01 8666 0600

4. Service tools

The following drawings and tables show special, standard and torque tools for service.

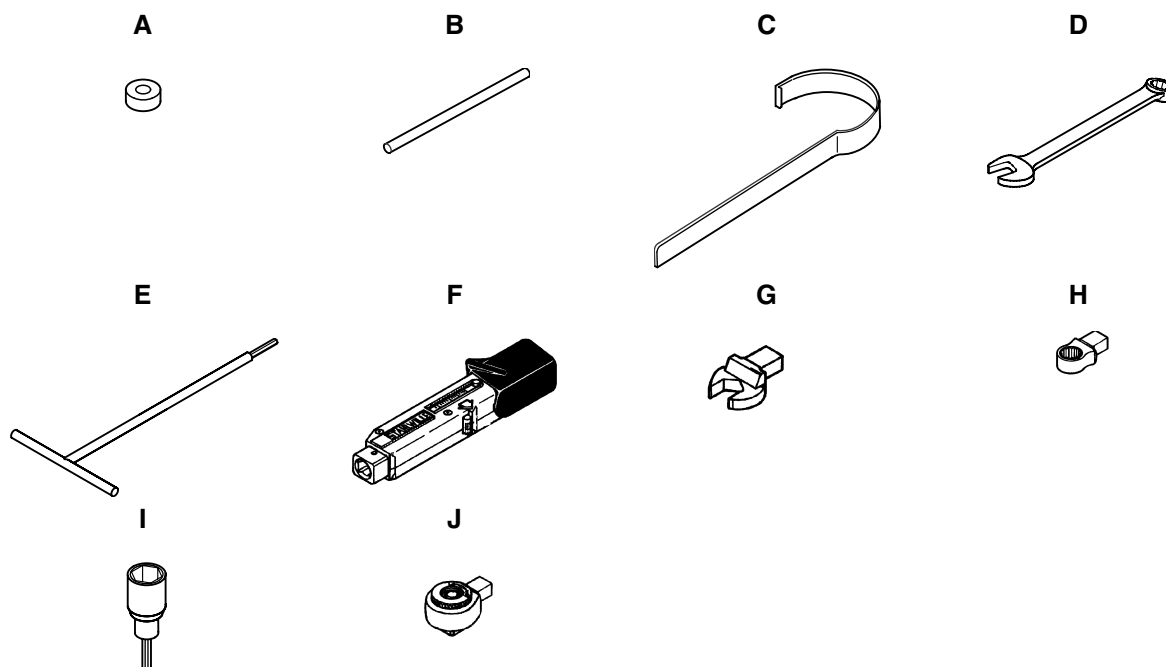

4.1 Special tools

Pos.	Description	For pos.	Suppl. information	Part no.
A	Spacing pipe		ø25/ø12 -10 mm	SV0331
B	Punch		ø5 - 120 mm	SV0332
C	Strap holder			SV0330

4.2 Standard tools

Pos.	Description	For pos.	Suppl. information	Part no.
D	Ring/open-end spanner	28	M5 - 8 mm	SV0273
			M6 - 10 mm	SV0083
		36 - 67	M8 - 13 mm	SV0055
E	Tee key	9	M6 - 5 mm	SV0124

4.3 Torque tools

Pos.	Description	For pos.	Suppl. information	Part no.
F	Torque wrench		4-20 Nm 9 x 12	SV0292
G	Open-end insert tool	36 - 67	M8 - 13 mm 9 x 12	SV0293
H	Ring insert tool	28	M5 - 8 mm 9 x 12	SV0411
			M6 - 10 mm 9 x 12	SV0310
			M8 - 13 mm 9 x 12	SV0294
I	Hexagon socket driver	9	M6 - 5 mm ½" x ½"	SV0296
J	Ratchet insert tool	F - I	9 x 12 x ½" x ½"	SV0295

5. Dismantling and assembly

5.1 General information

If it is necessary to dismantle the pump, either because it is choked or damaged, please follow the instructions in the following sections.

Position numbers of parts (digits) refer to exploded views, sectional drawings and parts lists; position numbers of tools (letters) refer to section [4. Service tools](#).

5.1.1 Before dismantling

- Disconnect the electricity supply to the motor.
- Remove the discharge pipe.
- *Remove the electric cable in accordance with local regulations.*
- Remove the pump from a possible condensate tank.

5.1.2 Before assembly

- Clean and check all parts.
- Order the necessary service kits.
- Replace defective parts by new parts.
- Gaskets and O-rings should always be replaced when the pump is overhauled.

5.1.3 During assembly

- Lubricate and tighten screws and nuts to the torque stated in section [2. Torques and lubricants](#).

5.1.4 After assembly

Test the pump according to the following test specifications:

SPK 1	96436698
SPK 2	96436699
SPK 4	96436700

5.2 Dismantling

Slacken the screws pos. 7a and remove them together with the coupling guards pos. 7 or remove the coupling guards from the pump head pos. 2 using a screwdriver.

Remove the screws pos. 9, the coupling pos. 8 and the shaft pin pos. 10.

Slacken and remove the screws pos. 28. Lift off the motor.

During dismantling, hold the shaft to the pump head by means of the spacing pipe [pos. A](#) and the punch [pos. B](#).

Fit the spacing pipe [pos. A](#) to the shaft and push it until it touches the pump head. Insert the punch [pos. B](#) in the shaft pin hole.

If the punch [pos. B](#) cannot be fitted, raise the shaft until the hole is free of the spacing pipe.

Remove the straps pos. 26 by slackening the nuts pos. 36 and removing them together with the washers pos. 66a.

Turn the pump so that it stands on the pump head with the strainer pos. 84 upwards.

Slacken the screw pos. 84b (model D) and remove it together with the strainer pos. 84 and the retainer for strainer pos. 121.

Slacken and remove the nut pos. 67.

Pull the other parts up to and including pos. 61 off the pump shaft one by one, see section [6. Order of assembly for chambers and impellers](#).

If the chambers stick, loosen them by inserting two screwdrivers between the chambers and turning them.

Remove the punch [pos. B](#) and the spacing pipe [pos. A](#).

Do not expose the rotating seal ring to blows or knocks.

Lift the shaft pos. 51 with the rotating shaft seal part out of the pump head.

Pull the shaft seal off the shaft.

If the stop ring pos. 62 is defective, push it out of the recess and pull it off the shaft (towards the threaded end).

Do not expose the stationary seal ring to blows or knocks.

Carefully push the seal ring and the O-ring out of the pump head (from the motor side).

Neck ring pos. 45

Chambers without impellers have not neck rings.

In the case of chambers with neck ring, replace the neck ring by inserting a screwdriver between the neck ring and the disc pos. 45a or the chamber.

The disc is only to be replaced if it has been damaged.

5.3 Assembly

Before assembly, clean and check all parts. Replace defective or worn parts.

The permissible maximum difference between the diameters of the bearing pos. 47a and the bearing in the chamber pos. 4a is 0.4 mm.

Chambers

If the neck rings have been removed, fit new neck rings.

No neck rings are fitted in chambers without impellers.

Position the disc pos. 45a in the recess of the chamber (not used in bottom chamber pos. 5a).

Press the neck ring into the chamber. *The PTFE disc on the neck ring must be uppermost, see [fig. 1](#)*

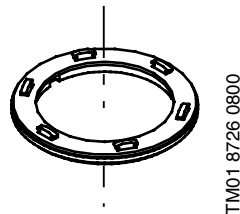

Fig. 1

Make sure that the parts are positioned correctly, see section [6. Order of assembly for chambers and impellers](#).

Fit the stop ring pos. 62 and the spacer pos. 61 over the spline of the shaft.

The stop ring must engage with the recess of the shaft.

Fit the rotating shaft seal part to the cylindrical part of the shaft, see section [3. Shaft seals](#).

Moisten the rubber parts of the shaft seal with water.

Make sure that the O-ring is not damaged on the pin hole and do not expose the seal rings to blows or knocks.

Before fitting the stationary seal ring in the pump head, position the latter on the table with the motor flange downwards.

Clean the recess of the pump head and moisten it with water, before the seal ring with the O-ring is pressed into the pump head. The O-ring must point towards the pump head.

Fit the shaft in the pump head with the threaded end pointing upwards.

Make sure that the rotating seal ring does not slide off the shaft.

Hold the shaft to the pump head by pushing the spacing pipe [pos. A](#) past the shaft pin hole in which the punch [pos. B](#) is fitted.

For further assembly of the pump, see section [6. Order of assembly for chambers and impellers](#). The table shows the assembly step by step, the position numbers and the order of assembly.

Assemble the pump from the top towards the bottom.

When the priming screw pos. 122 is fitted, the pipe end without priming screw must point towards the impeller.

Tighten the nut pos. 67 to the torque stated, see section [2. Torques and lubricants](#).

Make sure that the slots for the straps in the retainer for strainer are aligned to the points where the straps attach to the pump head.

Fit the straps pos. 26, the washers pos. 66a and the nuts pos. 36.

Hold the straps to the pump by means of the holder [pos. C](#) (see [fig. 2](#)) and tighten the nuts, see section [2. Torques and lubricants](#).

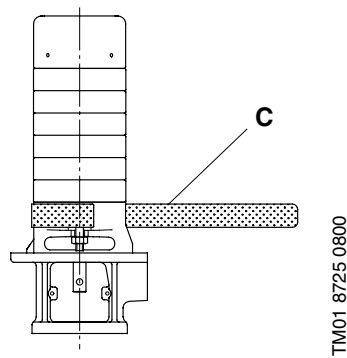

Fig. 2

Fit the strainer pos. 84 (and in the case of model D, secure it by means of the screw pos. 84b).

The pump body is now assembled, and the holder [pos. C](#), the punch [pos. B](#) and the spacing pipe [pos. A](#) can be removed.

Fit the motor and turn it to the required terminal box position.

Fit the screws pos. 28 and tighten diagonally, see section [2. Torques and lubricants](#).

Fit the shaft pin pos. 10 in the shaft. Fit the coupling halves. Fit the screws in the coupling, tighten and leave loose.

Check that the gaps either side of the coupling halves are equal.

Raise the pump body to its highest position by means of a large screwdriver inserted under the coupling. Take care not to raise the motor shaft. Lower the pump body 1-1.5 mm from its top position and tighten the screws two and two from the same side, see section [2. Torques and lubricants](#).

Check that the gaps either side of the coupling halves are equal and check the pump by turning the coupling. If the pump is tight or it cannot be rotated, a further adjustment should be carried out.

Spring the coupling guards pos. 7 into place in the pump head or secure them by means of the screws pos. 7a.

The pump is now assembled. Check the head and flow according to the test specifications.

6. Order of assembly for chambers and impellers

1. Determine the pump type (SPK 1, SPK 2 or SPK 4) and the stage variant. Find the pump in the relevant stage survey.
2. Find the components of each stage in section [6.2 Symbol survey](#).

6.1 Stage survey

6.1.1 SPK 1

140		182		224			287			350				434				518										
SPK 1-																												
1/		3/		5/			8/			11/				15/				19/										
1	3	1	5	3	1	8	5	3	1	11	8	5	3	1	15	11	8	5	3	1	19	15	11	8	5	3	1	
●	★	●	●	★	●	●	●	★	●	●	●	●	●	★	●	●	●	●	●	●	★	●	●	●	●	●	●	★
○	★	●	○	★	●	●	○	★	●	●	●	○	★	●	●	●	○	★	★	★	●	●	●	●	○	★	★	
○	★	★	○	★	★	●	○	★	★	●	●	○	★	★	●	●	○	★	★	★	●	●	●	●	○	★	★	
●	★	★	★	★	●	●	★	★	★	●	●	★	★	★	●	●	★	★	★	★	●	●	●	●	★	★	★	
●	★	★	★	★	●	●	★	★	★	●	●	★	★	★	●	●	★	★	★	★	●	●	●	●	○	★	★	
●	★	★	★	★	●	●	★	★	★	●	●	★	★	★	●	●	★	★	★	★	●	●	●	●	★	★	★	
○	★	★	★	★	●	●	★	★	★	●	●	★	★	★	●	●	★	★	★	★	●	●	●	●	★	★	★	
●	★	★	★	★	●	●	★	★	★	●	●	★	★	★	●	●	★	★	★	★	●	●	●	●	★	★	★	
●	★	★	★	★	●	●	★	★	★	●	●	★	★	★	●	●	★	★	★	★	●	●	●	●	★	★	★	
○	★	★	★	★	●	●	★	★	★	●	●	★	★	★	●	●	★	★	★	★	●	●	●	●	★	★	★	
●	★	★	★	★	●	●	★	★	★	●	●	★	★	★	●	●	★	★	★	★	●	●	●	●	★	★	★	
●	★	★	★	★	●	●	★	★	★	●	●	★	★	★	●	●	★	★	★	★	●	●	●	●	★	★	★	
○	★	★	★	★	●	●	★	★	★	●	●	★	★	★	●	●	★	★	★	★	●	●	●	●	★	★	★	

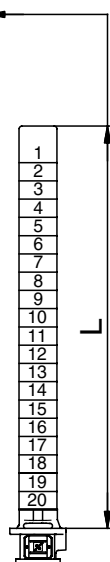

602										1005													
SPK 1-																							
23/									23/														
23	19	15	11	8	5	3	1	23	19	15	11	8	5	3	1	23	19	15	11	8	5	3	1
●	●	●	●	●	●	●	★	●	●	●	●	●	●	●	★	●	●	●	●	●	●	●	★
●	●	●	●	●	●	○	★	●	●	●	●	●	●	●	+	★	●	●	●	●	●	●	★
●	●	●	●	●	●	○	★	●	●	●	●	●	●	●	+	★	●	●	●	●	●	●	★
●	●	●	●	●	●	★	★	●	●	●	●	●	●	●	+	★	●	●	●	●	●	●	★
●	●	●	●	●	●	★	★	●	●	●	●	●	●	●	+	★	●	●	●	●	●	●	★
●	●	●	●	●	●	★	★	●	●	●	●	●	●	●	+	★	●	●	●	●	●	●	★
●	●	●	●	●	●	★	★	●	●	●	●	●	●	●	+	★	●	●	●	●	●	●	★
●	●	●	●	●	●	★	★	●	●	●	●	●	●	●	+	★	●	●	●	●	●	●	★
●	●	●	●	●	●	★	★	●	●	●	●	●	●	●	+	★	●	●	●	●	●	●	★
●	●	●	●	●	●	★	★	●	●	●	●	●	●	●	+	★	●	●	●	●	●	●	★
●	●	●	●	●	●	★	★	●	●	●	●	●	●	●	+	★	●	●	●	●	●	●	★
●	●	●	●	●	●	★	★	●	●	●	●	●	●	●	+	★	●	●	●	●	●	●	★
●	●	●	●	●	●	★	★	●	●	●	●	●	●	●	+	★	●	●	●	●	●	●	★
●	●	●	●	●	●	★	★	●	●	●	●	●	●	●	+	★	●	●	●	●	●	●	★
●	●	●	●	●	●	★	★	●	●	●	●	●	●	●	+	★	●	●	●	●	●	●	★
○	★	★	★	★	★	★	★	★	★	★	★	★	★	★	+	★	★	★	★	★	★	★	★
●	★	★	★	★	★	★	★	★	★	★	★	★	★	★	+	★	★	★	★	★	★	★	★
●	★	★	★	★	★	★	★	★	★	★	★	★	★	★	+	★	★	★	★	★	★	★	★
●	★	★	★	★	★	★	★	★	★	★	★	★	★	★	+	★	★	★	★	★	★	★	★
○	★	★	★	★	★	★	★	★	★	★	★	★	★	★	+	★	★	★	★	★	★	★	★

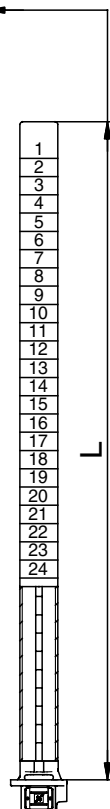

TM01 8579 0400

6.1.2 SPK 2

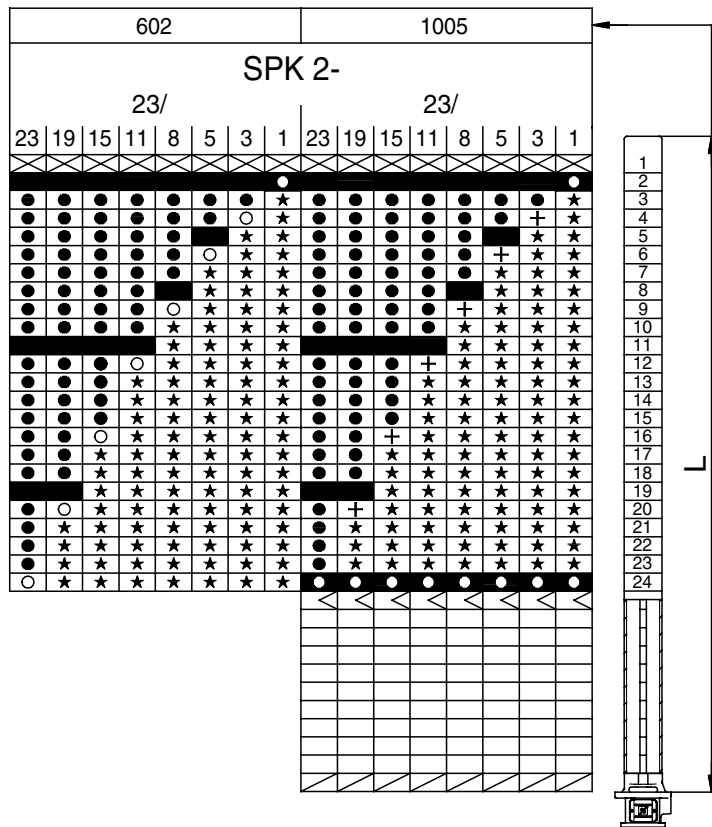
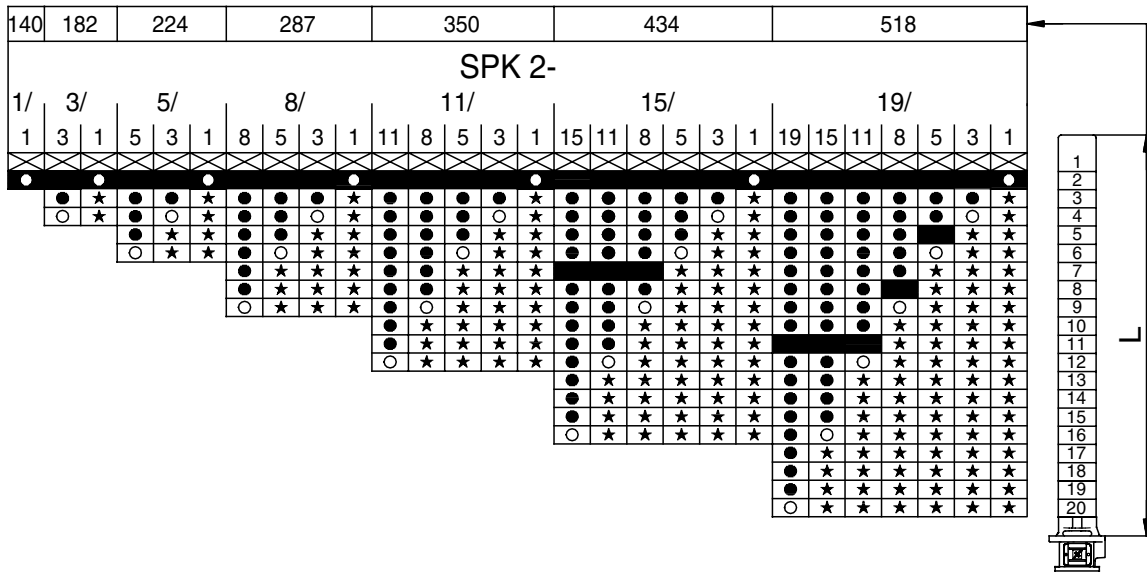

TM01 8651 0600

6.1.3 SPK 4

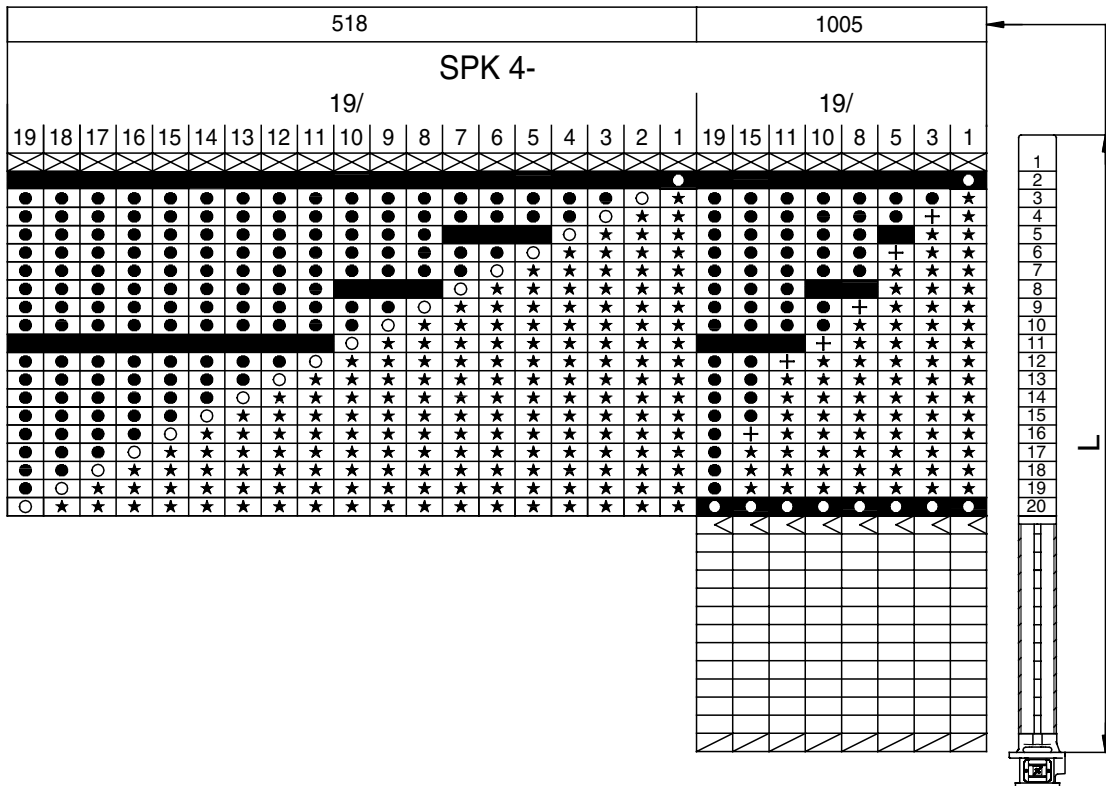
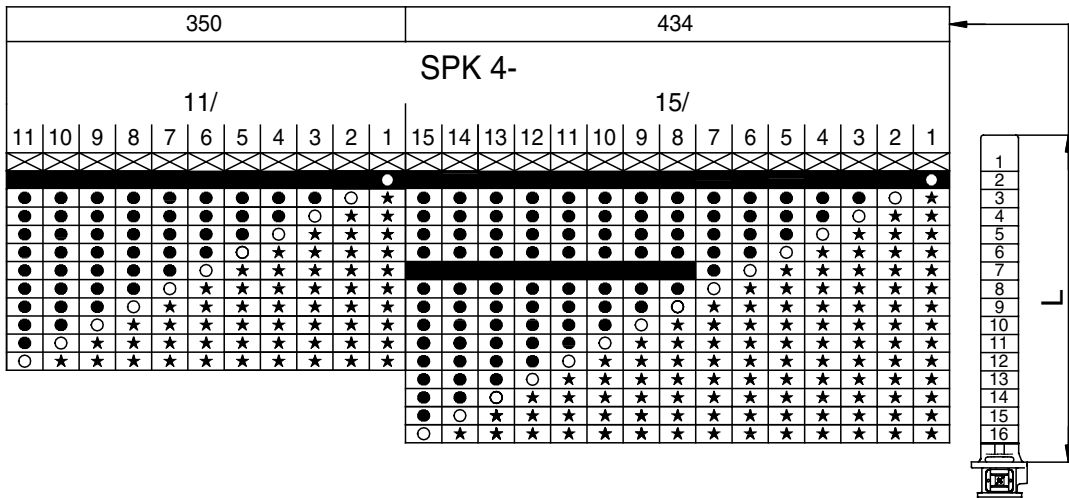
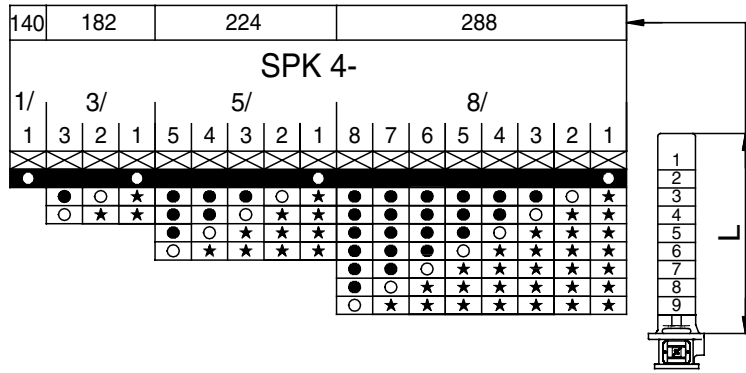

TM01 8653 0600

6.2 Symbol survey

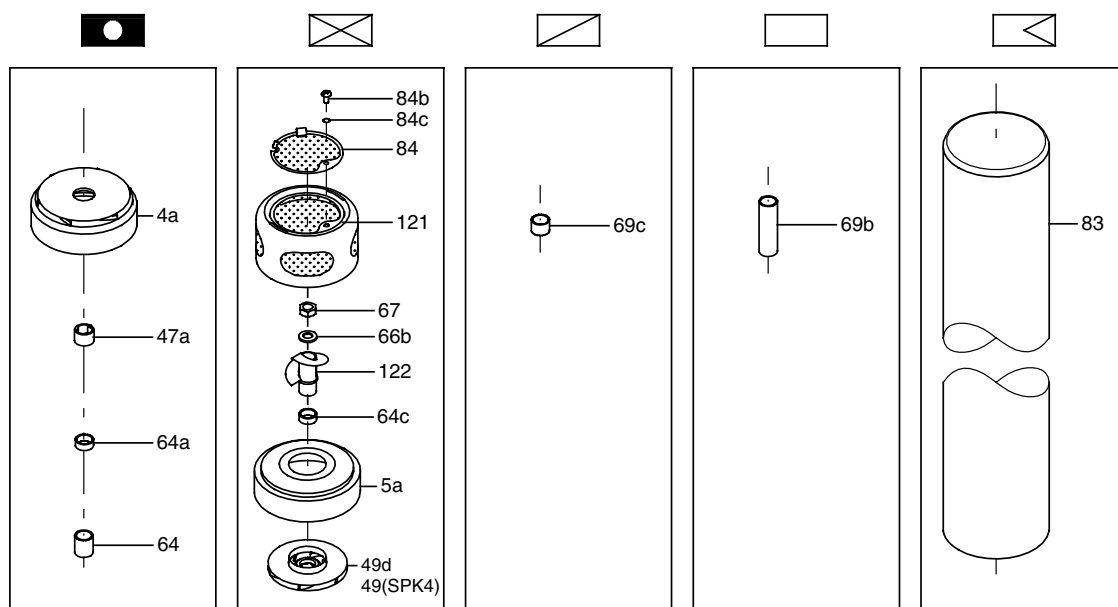
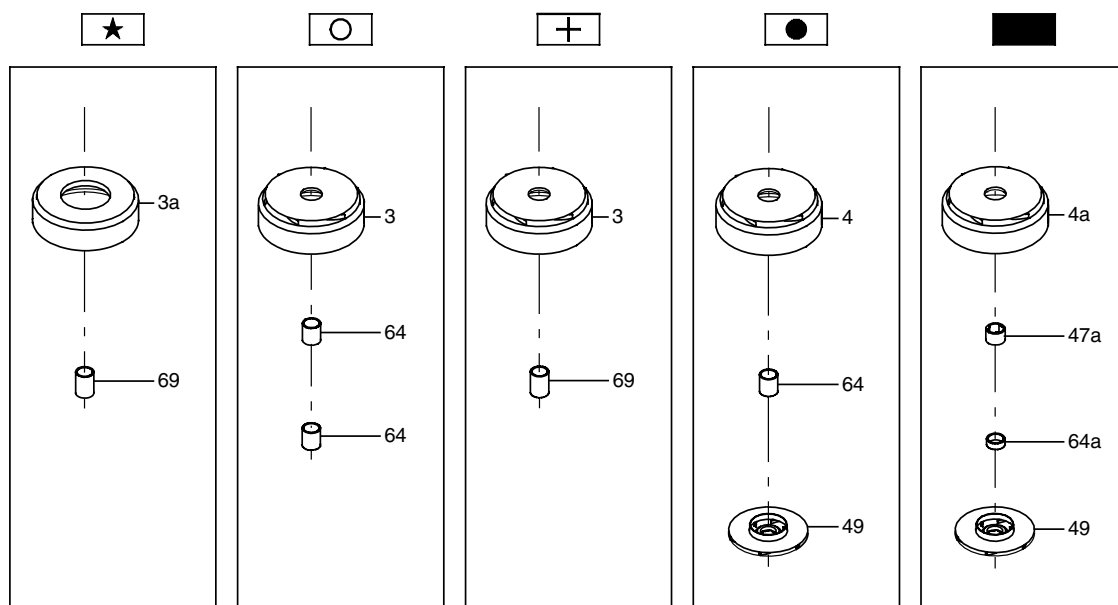

TM01 8578 3202