

JP

Jet pumps
50 Hz



Contents

General data

Application	3
Pumped liquids	3
Duty range	3
Pump	3
Motor	3
Materials	3
Ejector settings	3
JP 5 performance curves	4
JP 6 performance curves	4
Electrical data	4
Presscontrol	4
Diaphragm tank	4

Technical data

Material variant A	5
JP booster	5
Material variant B	5
Presscontrol	5
Weights	5

Further product documentation

WebCAPS	6
WinCAPS	7

Application

Built for long trouble-free life, the small and handy Grundfos jet pump is suitable for a wide variety of water supply and transfer duties in home, garden and hobby applications as well as in agriculture, horticulture and small-scale service industries.

Combined with Presscontrol or tank for demand control the Jet pump is ideal for small water supply systems.

Pumped liquids

Clean, thin, non-aggressive and non-explosive liquids without solid particles or fibres. Use of the pump for pumping unclean liquids, such as pool water, requires subsequent flushing with clean water. The pump must not be used for transfer of diesel oil or other oil-containing liquids.

Duty range

Flow, Q: Up to 117 l/min (7 m³/h).
 Head, H: Maximum 48 metres.
 Operating pressure: Maximum 6 bar.
 Suction lift: Maximum 8 metres, including suction

pipe pressure loss at a liquid temperature of +20°C.

Liquid temperature: Material variant A: 0°C to +40°C.
 Material variant B: 0°C to +55°C.

Ambient temperature: Maximum +40°C.

Pump

The JP pump is a self-priming, single-stage centrifugal pump with axial suction port and radial discharge port, G 1 or Rp 1. The pump has a built-in ejector with guide vanes for optimum self-priming properties.

JP pumps are available in two material variants:

Material variant A: Cover plate, motor stool and base plate in one unit. The handle is fitted crosswise. Both are made of composite material.

Material variant B: Stainless steel cover plate, aluminium motor stool and stainless steel base plate, all separate parts. The robust design makes the pump suitable for fixed installation. The custom-built composite handle is fitted lengthwise.

For further information about the material specifications of the pump, see "Materials".

Motor

The pump is directly coupled to a special fan-cooled asynchronous Grundfos motor, adapted to the pump performance. Single-phase motors have a built-in thermal switch and require no additional motor protection. Three-phase motors require external motor protection.

Enclosure class: IP 44 (splash-proof).

Insulation class: F.

Materials

Shaft seal	Material	DIN W.-Nr.	AISI
Stationary seat	Carbon		
Rotating face	Ceramic		
Spring	Stainless steel	1.4301	304
Housing for rotating face	Stainless steel	1.4301	304
O-rings	NBR rubber		
Other parts			
Shaft	Steel 52		
Impeller	Stainless steel	1.4301	304
Pump sleeve	Stainless steel	1.4301	304
Clamps	Stainless steel	1.4301	304
Ejector	Composite		
Seal ring	PPE composite		
O-rings	NBR rubber		
Material variant A			
Motor stool with base plate	Composite		
Bearing plate	Stainless steel	1.4301	304
Material variant B			
Motor stool	Aluminium		
Base plate	Stainless steel	1.4301	304
Cover plate	Stainless steel	1.4301	304

Ejector settings

The JP pump design features a built-in ejector, fitted with an ejector valve or a plug.

The ejector valve has two setting possibilities:

- Position 1: Completely open ejector nozzle.
- Position 2: Completely closed ejector nozzle.

The plug allows only selection of position 1.

Position 1 is used for

- start-up when the suction pipe is empty and the pump is to be primed
- maximum discharge pressure
- maximum head and minimum flow
- pressure boosting in connection with car washing, etc.

Position 2 is used for

- maximum flow at reduced pressure
- maximum pump efficiency
- low noise level
- draining and similar tasks as well as in installations with positive head on the suction side.

JP 5 performance curves

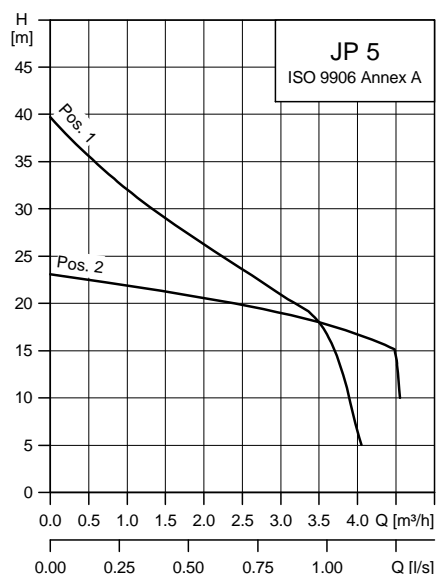

TM00 7474 1401

JP 6 performance curves

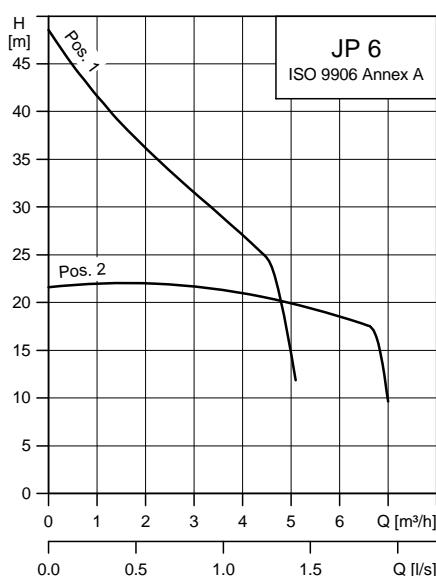

TM00 7475 1401

Electrical data

JP 5, 50 Hz	P ₁ [W]	n [min ⁻¹]	Cos φ	I _n [A]	$\frac{I_{st}}{I_1/1}$
1 x 220-230 V	775	2650	0.99	3.7	3.5
1 x 230-240 V	775	2650	0.98	3.4	3.4
3 x 220-240 V	780	2830	0.87	2.4	2.9
3 x 380-415 V	780	2830	0.87	1.4	5.0

JP 6, 50 Hz	P ₁ [W]	n [min ⁻¹]	Cos φ	I _n [A]	$\frac{I_{st}}{I_1/1}$
1 x 220-240 V	1350	2800	0.90	6.2	4.2
3 x 220-240 V	1325	2850	0.81	4.1	3.9
3 x 380-415 V	1325	2850	0.81	2.4	6.8

Presscontrol

Presscontrol, types PC 15 and PC 22, with preset cut-in pressure at 1.5 and 2.2 bar, respectively, is used for automatic operation of pumps in minor water supply systems.

A built-in flow valve and pressure switch ensure a steady flow without water hammering, irrespective of the water consumption. Presscontrol starts and stops the pump automatically according to demand. In addition, the built-in dry-running protection stops the pump after 10 seconds of operation without water.

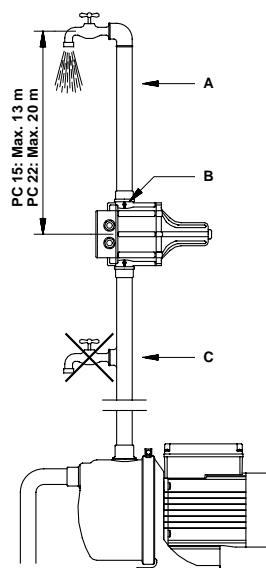

TM00 5589 1696

A

It is recommended to make the installation in such a way that the difference of height between the Presscontrol and the highest tap point does not exceed the stated values.

B

The arrows on the Presscontrol indicate the direction of flow. The Presscontrol must always be installed in such a way that the arrows point upwards.

C

No tap points are allowed between pump and Presscontrol.

Diaphragm tank

Diaphragm tanks are recommended for use with the JP pump where it is necessary to ensure a controlled pressure in the water supply system.

Grundfos offers a range of small booster sets, each complete with a jet pump and one of the following tanks:

- 24 litres horizontal tank
- 50 litres horizontal tank
- 18 litres vertical tank

Material variant A

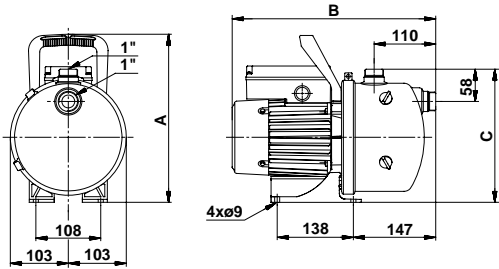

Pump type	Dimensions [mm]		
	A	B	C
JP 5, material variant A	300	364	240
JP 6, material variant A	300	401	240

Material variant B

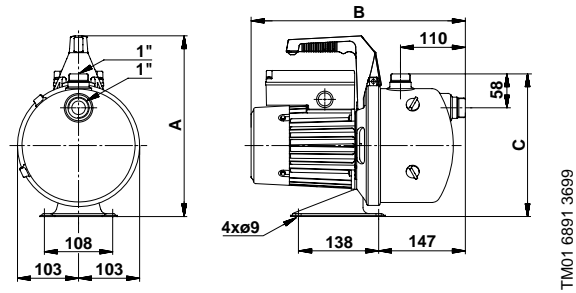

Pump type	Dimensions [mm]		
	A	B	C
JP 5, material variant B	306	364	240
JP 6, material variant B	306	401	240

JP booster

JP with horizontal diaphragm tank

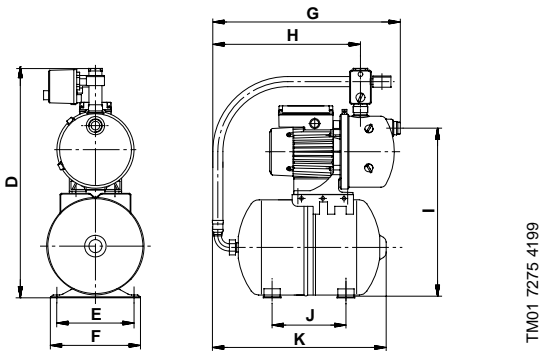

JP with vertical diaphragm tank

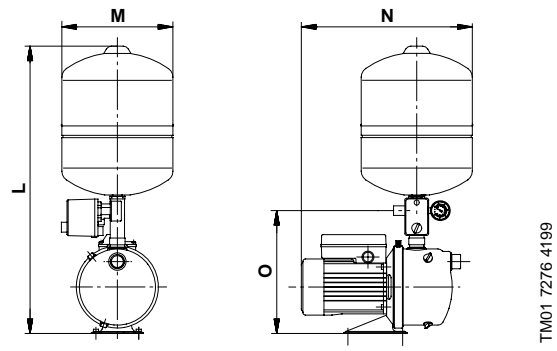

Pump type	Tank size [l]	Dimensions [mm]											
		D	E	F	G	H	I	J	K	L	M	N	O
JP 5, JP 6	24	677	240	275	526	415	510	210	496	-	-	-	-
JP 5, JP 6	50	762	288	347	556	445	585	-	594	-	-	-	-
JP 5, JP 6	18	-	-	-	-	-	-	-	-	692	270	389	316

Presscontrol

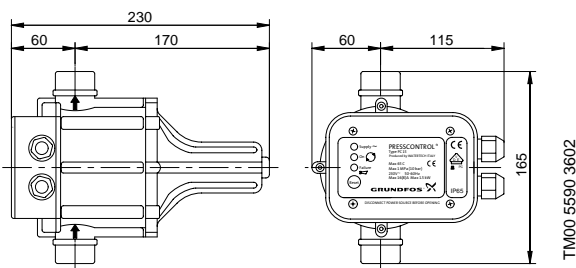

Weights

Type	Connection	Tank size [l]	Weights [kg]	
			Net	Gross
JP 5	G 1 / Rp 1	18	15.3	-
		24	17.1	19.1
		50	22.0	24.0
JP 6	G 1 / Rp 1	18	18.6	-
		24	20.4	22.4
		50	25.0	28.0
Presscontrol	G 1	-	-	1.2

WebCAPS

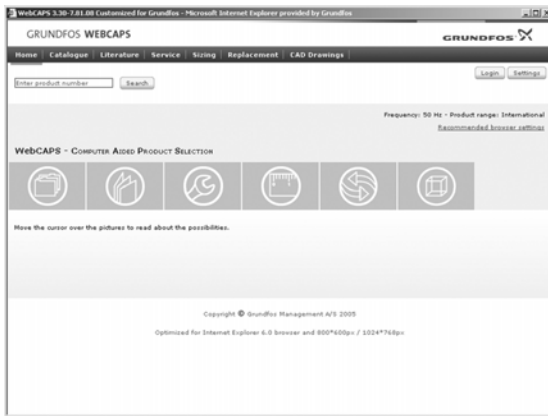

WebCAPS is a **Web**-based **Computer Aided Product Selection** program available on www.grundfos.com.

WebCAPS contains detailed information on more than 185,000 Grundfos products in more than 20 languages.

In WebCAPS, all information is divided into 6 sections:

- Catalogue
- Literature
- Service
- Sizing
- Replacement
- CAD drawings.



Catalogue

With a starting point in areas of applications and pump types, this section contains

- technical data
- curves (QH, Eta, P1, P2, etc) which can be adapted to the density and viscosity of the pumped liquid and show the number of pumps in operation
- product photos
- dimensional drawings
- wiring diagrams
- quotation texts, etc.

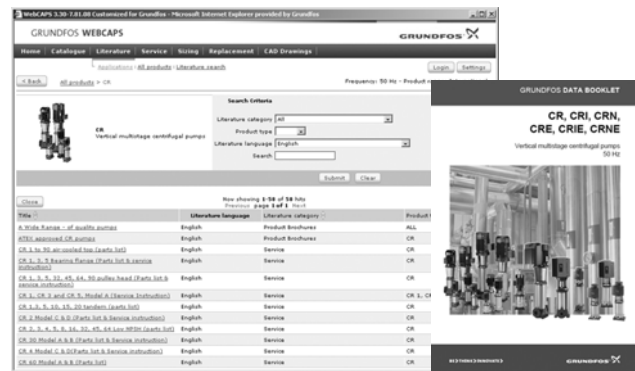

Literature

In this section you can access all the latest documents of a given pump, such as

- data booklets
- Installation and operating instructions
- service documentation, such as Service kit catalogue and Service kit instructions
- quick guides
- product brochures, etc.

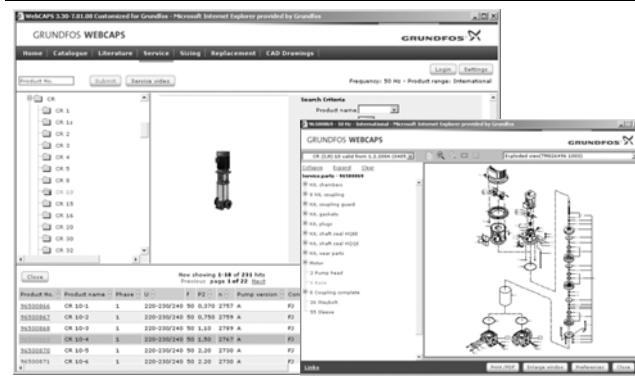

Service

This section contains an easy-to-use interactive service catalogue. Here you can find and identify service parts of both existing and cancelled Grundfos pumps. Furthermore, this section contains service videos showing you how to replace service parts.



Sizing

With a starting point in different application areas and installation examples, this section gives easy step-by-step instructions in how to

- select the most suitable and efficient pump for your installation
- carry out advanced calculations based on energy consumption, payback periods, load profiles, lifecycle costs, etc.
- analyse your selected pump via the built-in lifecycle cost tool
- determine the flow velocity in wastewater applications, etc.



Replacement

In this section you find a guide to select and compare replacement data of an installed pump in order to replace the pump with a more efficient Grundfos pump.

The section contains replacement data of a wide range of pumps produced by other manufacturers than Grundfos.

Based on an easy step-by-step guide, you can compare Grundfos pumps with the one you have installed on your site. After having specified the installed pump, the guide suggests a number of Grundfos pumps which can improve both comfort and efficiency.



CAD drawings

In this section it is possible to download 2-dimensional (2D) and 3-dimensional (3D) CAD drawings of most Grundfos pumps.

The following formats are available in WebCAPS:

2-dimensional drawings

- .dxf, wireframe drawings
- .dwg, wireframe drawings.

3-dimensional drawings

- .dwg, wireframe drawings (without surfaces)
- .stp, solid drawings (with surfaces)
- .eprt, E-drawings.

WinCAPS



Fig. 1 WinCAPS CD-ROM

WinCAPS is a **Windows-based Computer Aided Product Selection** program containing detailed information on more than 185,000 Grundfos products in more than 22 languages.

The program contains the same features and functions as WebCAPS, but is an ideal solution if no Internet connection is available.

WinCAPS is available on CD-ROM and updated once a year.

V7112680 0407	GB
Repl. V7112680 0206	

Subject to alterations.