

# Conlift

Installation and operating instructions

GB D F I NL DK PL



## **(GB) Declaration of Conformity**

We **Grundfos** declare under our sole responsibility that the products **Conlift**, to which this declaration relates, are in conformity with these Council Directives on the approximation of the laws of the EC Member States:

- Low Voltage Directive (2006/95/EC).  
Standards used: EN 60335-1: 2002 and EN 60335-2-41: 2003\*).
- EMC Directive (2004/108/EC).  
Standards used: EN 55014-1: 2007, EN55014-2: 1997 and EN55014-2/A1: 2002.

\*) The lifting station must be protected against splashing water (in compliance with IP X4).

## **(F) Déclaration de Conformité**

Nous **Grundfos** déclarons sous notre seule responsabilité que les produits **Conlift**, auxquels se réfère cette déclaration sont conformes aux Directives du Conseil concernant le rapprochement des législations des Etats membres CE relatives à/au(x):

- Directive de basse tension (2006/95/CE)  
Normes utilisées: EN 60335-1: 2002 et EN 60335-2-41: 2003\*).
- Compatibilité électromagnétique (2004/108/CE)  
Normes utilisées: EN 55014-1: 2007, EN55014-2: 1997 et EN55014-2/A1: 2002.

\*) Le récupérateur doit être installé de manière à être protégé des projections d'eau (selon IP X4).

## **(NL) Overeenkomstigheidsverklaring**

Wij **Grundfos** verklaren, geheel onder eigen verantwoordelijkheid, dat de producten **Conlift**, waarop deze verklaring betrekking heeft, in overeenstemming zijn met de Richtlijnen van de Raad inzake onderlinge aanpassing van de wetgevingen van de Lidstaten.

- Laagspannings Richtlijn (2006/95/EC)  
Gebruikte normen: EN 60335-1: 2002 en EN 60335-2-41: 2003\*).
- EMC Richtlijn (2004/108/EC).  
Gebruikte normen: EN 55014-1: 2007, EN55014-2: 1997 en EN55014-2/A1: 2002.

\*) Het hevelstation moet beschermd worden tegen opspattend water (in overeenstemming met IP X4).

## **(PL) Deklaracja zgodności**

My **Grundfos**, oświadczamy z pełną odpowiedzialnością, że nasze wyroby **Conlift**, których deklaracja niniejsza dotyczy, są zgodne z następującymi wytycznymi Rady d/s ujednolicenia przepisów prawnych krajów WE:

- Dyrektywa Niskich Napięć (2006/95/WE),  
Zastosowane normy: EN 60335-1: 2002 i EN 60335-2-41: 2003\*).
- Dyrektywa EMC (2004/108/WE),  
Zastosowane normy: EN 55014-1: 2007, EN55014-2: 1997 en EN55014-2/A1: 2002.

\*) Agregat pompowy musi być zabezpieczony przed możliwością opryskiwania wodą (zgodnie z wymaganiami dla stopnia ochrony IP X4).

## **(D) Konformitätserklärung**

Wir **Grundfos** erklären in alleiniger Verantwortung, dass die Produkte **Conlift**, auf die sich diese Erklärung bezieht, mit den folgenden Richtlinien des Rates zur Angleichung der Rechtsvorschriften der EU-Mitgliedsstaaten übereinstimmen:

- Niederspannungsrichtlinie (2006/95/EG)  
Verwendete Normen: EN 60335-1: 2002 und EN 60335-2-41: 2003\*).
- EMV-Richtlinie (2004/108/EG).  
Verwendete Normen: EN 55014-1: 2007, EN55014-2: 1997 und EN55014-2/A1: 2002..

\*) Die Hebeanlage muss so aufgestellt werden, dass sie gegen Spritzwasser geschützt ist (entsprechend IP X4).

## **(I) Dichiarazione di Conformità**

**Grundfos** dichiara sotto la sua esclusiva responsabilità che i prodotti **Conlift**, ai quali si riferisce questa dichiarazione, sono conformi alle seguenti direttive del Consiglio riguardanti il riavvicinamento delle legislazioni degli Stati membri CE:

- Direttiva Bassa Tensione (2006/95/CE).  
Norme applicate: EN 60335-1: 2002 e EN 60335-2-41: 2003\*).
- Direttiva EMC (2004/108/CE).  
Norme applicate: EN 55014-1: 2007, EN55014-2: 1997 e EN55014-2/A1: 2002.

\*) La stazione di sollevamento deve essere protetta dagli spruzzi d'acqua (secondo IP X4).

## **(DK) Overensstemmelseserklæring**

Vi **Grundfos** erklærer under ansvar at produkterne **Conlift**, som denne erklæring omhandler, er i overensstemmelse med disse af Rådets direktiver om indbyrdes tilnærmelse til EF medlemsstaternes lovgivning:

- Lavspændingsdirektivet (2006/95/EC).  
Anvendte standarder: EN 60335-1: 2002 og EN 60335-2-41: 2003\*).
- EMC-direktivet (2004/108/EC).  
Anvendte standarder: EN 55014-1: 2007, EN55014-2: 1997 og EN55014-2/A1: 2002.

\*) Beholderanlægget skal installeres, så det er beskyttet mod vandspøjt (i henhold til IP X4).

Bjerringbro, 1 May 2008



Svend Aage Kaase  
Technical Director

# Conlift

<b>Installation and operating instructions</b>	<b>4</b>	<b>GB</b>
<b>Montage- und Betriebsanleitung</b>	<b>18</b>	<b>D</b>
<b>Notice d'installation et d'entretien</b>	<b>33</b>	<b>F</b>
<b>Istruzioni di installazione e funzionamento</b>	<b>47</b>	<b>I</b>
<b>Installatie- en bedieningsinstructies</b>	<b>61</b>	<b>NL</b>
<b>Monterings- og driftsinstruktion</b>	<b>75</b>	<b>DK</b>
<b>Instrukcja montażu i eksploatacji</b>	<b>89</b>	<b>PL</b>

# CONTENTS

	Page
1. Symbols used in this document	4
2. Delivery	4
3. General description	4
3.1 Applications	4
4. Function	5
5. Installation	6
5.1 Connections	6
5.2 Lifting station	6
5.3 Dimensions	6
5.4 Connection of inlet and discharge hoses	8
6. Electrical connection	10
7. Start-up	10
7.1 Checking the function	10
8. Maintenance and service	11
8.1 Cleaning the Conlift	11
8.2 Contaminated lifting station or components	11
9. Components	12
9.1 Service kit	13
9.2 Accessories	15
10. Fault finding chart	16
11. Technical data	17
11.1 Other technical data	17
12. Disposal	17

## Warning



**Prior to installation, read these installation and operating instructions. Installation and operation must comply with local regulations and accepted codes of good practice.**

## 1. Symbols used in this document

### Warning



**If these safety instructions are not observed, it may result in personal injury!**

### Caution

**If these safety instructions are not observed, it may result in malfunction or damage to the equipment!**

### Note

**Notes or instructions that make the job easier and ensure safe operation.**

## 2. Delivery

The Grundfos Conlift is delivered in a cardboard box containing:

- Conlift lifting station with built-in non-return valve and supply cable with Schuko plug or a free cable end
- Mounting kit in plastic bag
- Installation and operating instructions.

The mounting kit consists of (see pages 12 and 13): 5 metres of hose with internal/external diameter of 10/14 mm (pos. 51)

- 2 angular mounting brackets to counteract buoyancy (pos. 52)
- 4 wood screws (pos. 53) and 4 rawlplugs® (pos. 54)
- 1 hose clamp for fastening the discharge hose to the discharge stub (pos. 55)
- 4 mounting feet to be glued on (pos. 56)
- 1 strain-relief – for the use of external alarm/potential-free contact (pos. 19)
- 2 sheet metal screws for the strain-relief (pos. 20).

Check that all components are OK.

## 3. General description

The Grundfos Conlift is a compact lifting station with built-in non-return valve; it works automatically. The Conlift is ready for installation.

### 3.1 Applications

The Conlift is designed for the pumping of condensate from

- boilers
- air-conditioning systems
- cooling and refrigeration systems
- air dehumidifiers
- evaporators.

The Conlift is suitable for the pumping of condensate which is collected below sewer level or which cannot flow to the sewage system or drain of the building by natural gravitation.

### Caution

**The Conlift must only operate in 1.5 out of 10 minutes (S3 - 15 %) according to DIN VDE 0530 T1.**



**Condensates from boilers are aggressive. They contain acid.**

The Conlift can pump condensate with a pH value equal to or above 2.7 from boilers with a heat output of up to 200 kW.

This applies to boilers fired with the following:

- gas
- liquid gas
- low-sulphur fuel oil according to DIN 51 603-1.

Where boilers are fired with the above fuels, but

- have a heat output above 200 kW,
- produce condensate with a pH value below 2.7,

Note

and where boilers

- are fired with oils other than low-sulphur fuel oil,

**the condensate from the boiler must be neutralised before entering the sewage system/lifting station.**



**The Conlift must not be used for the transfer of inflammable liquids.**



**The Conlift must not be installed in potentially explosive environments.**

In case of deviations from the application conditions stated above, local electricity regulations and standards must be observed.

In case of doubt, contact a qualified electrician.

#### 4. Function

The condensate flows by natural gravitation through a hose into the lifting station, see section 5. *Installation.*

When the liquid level in the collecting tank reaches 60 mm, the pump starts automatically via pressure switch 1. When the liquid level falls below 35 mm, the pump stops.

The condensate is pumped through the discharge hose to the drain.

If the liquid level rises above 80 mm, the alarm (buzzer) is activated via pressure switch 2 (alarm pressure switch), and the pump starts (second cut-in).

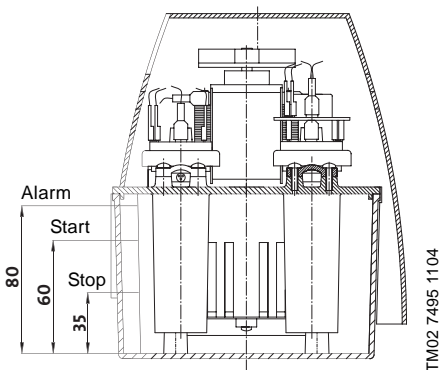

Fig. 1 Stop, start and alarm levels

## 5. Installation

Note

*The Conlift lifting station must be installed in accordance with local regulations.*

- The condensate must flow freely into the lifting station.
- The cooling slots in the motor cover must not be covered.
- Easy access to the lifting station must be provided to facilitate maintenance.
- The lifting station must be installed in a well-illuminated and -ventilated room.
- The lifting station must be protected against splashing water (in compliance with IP X4).

## 5.1 Connections

See fig. 2.

### Connection for inlet hose:

Inlet opening in collecting tank, internal diameter 24 mm.

### Connection for discharge hose:

Discharge stub above the built-in non-return valve, external diameter 12 mm.

### Electrical connection:

Supply cable with Schuko plug or a free cable end, 2 metres.

## 5.2 Lifting station

The Conlift must be mounted horizontally.

The Conlift can be mounted on the floor or on the wall.

Drilling template for the holes for wall mounting can be found at the end of this booklet.

Depending on the type of mounting, the mounting feet must be glued on the bottom or back of the Conlift.

## 5.3 Dimensions

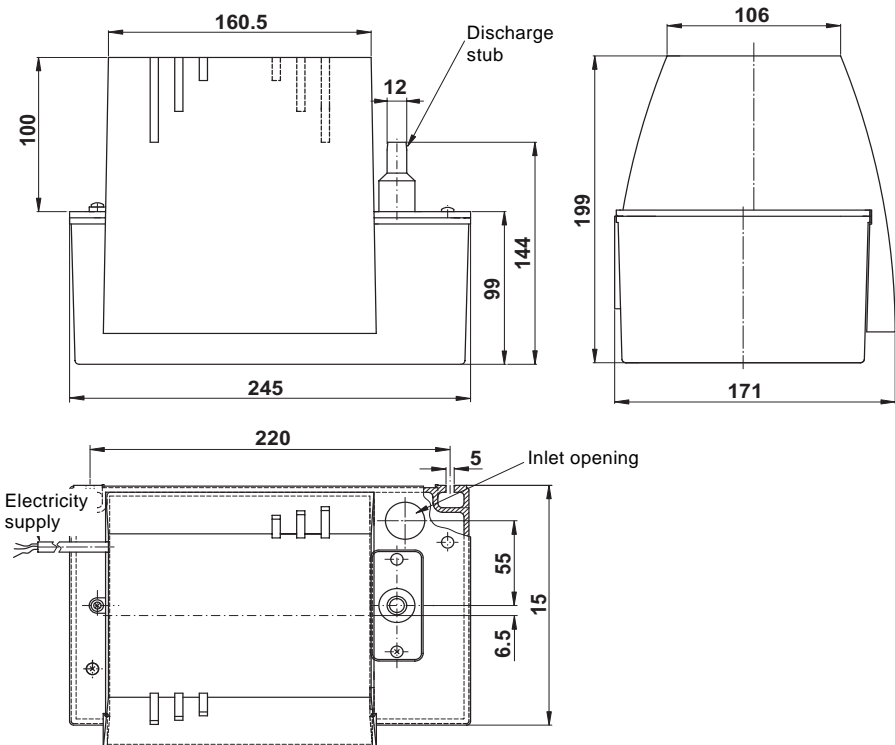

Fig. 2 Dimensional sketch

TM02 7496 3603

### 5.3.1 Securing the Conlift



**To prevent personal injury caused by electric shock, scalding hot water or acid, do not turn the Conlift upside down.**

If the Conlift is installed in a room where there is a risk of flooding, the angular mounting brackets must be used. They counteract the buoyancy of the Conlift (see figures 3 and 4), and thus prevent the collecting tank from tilting and the spillage of acid.

In rooms where there is no risk of flooding, the angular mounting brackets also prevent accidental

- overturning of the lifting station (floor mounting) or
- detachment of the lifting station from the wall (wall mounting).

This prevents the acid in the collecting tank from spilling out and causing damage.

GB

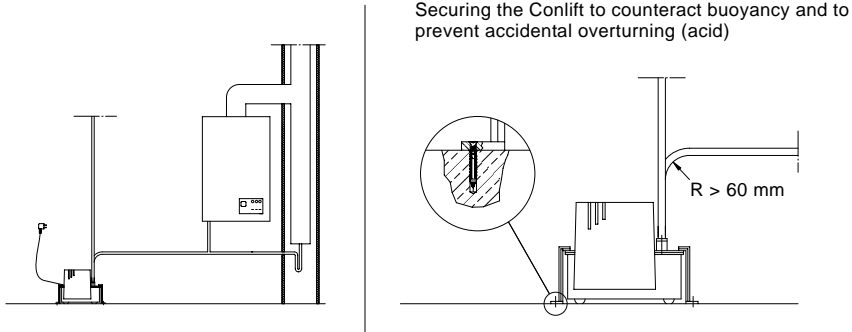

**Fig. 3** Floor mounting, securing the Conlift to counteract buoyancy

TM02 7499 3603

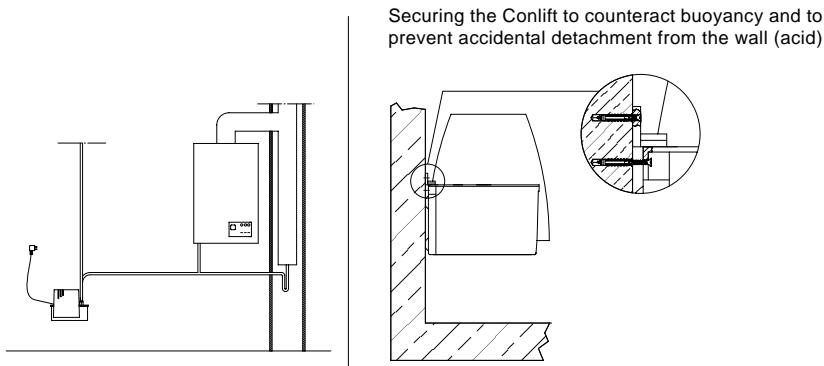

**Fig. 4** Wall mounting, securing the Conlift to counteract buoyancy

TM02 7498 3603

The Conlift must be mounted horizontally and secured by screws as shown in figures 3 and 4.

The Conlift must be mounted in a dry and frost-free room with good ventilation.

The angular mounting brackets counteract buoyancy, e.g. in connection with temporary flooding.

## 5.4 Connection of inlet and discharge hoses

The hose supplied as an accessory can be used as inlet and discharge hose.

GB

- Attach the hose to the wall.  
Distance between attachment points:  
Approx. 30 cm.
- Make sure that the hose does not sag or is squeezed.
- Avoid sharp bends. The bending radius of the hose must be at least 60 mm.
- Run the inlet and discharge hoses in such a way that they do not strain the Conlift.

### 5.4.1 Inlet hose

- When running the inlet hose from the boiler or cooling/air-conditioning system to the Conlift, make sure that the condensate flows freely into the collecting tank.
- Insert the inlet hose sufficiently deep into the tank through the inlet opening, see fig. 7. It is recommended to make a sloping cut to the hose.

### 5.4.2 Discharge hose

- Pass the discharge hose end over the discharge stub (the grommet should not be lubricated with grease), see fig. 7. Fasten the hose with the clamp supplied with the lifting station.
- Take the discharge hose vertically up to the highest point from where the condensate can flow freely into the sewage system or drain of the building.
- If the Conlift is positioned below sewer level, the hose must have a return loop at the highest point. The lower edge of the loop must be 10 to 20 cm above sewer level (the sewer level usually corresponds to the street level).
- At the highest point, a loop must be formed. The bending radius of the hose must be at least 60 mm.

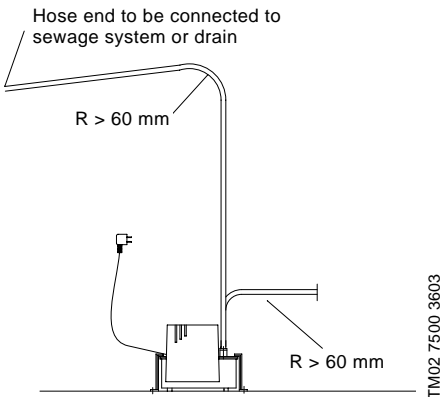

Fig. 5 Arrangement of hoses

### 5.4.3 External alarm/potential-free contact

**Before starting work on the Conlift, the electricity supply must be switched off. It must be ensured that the electricity supply cannot be accidentally switched on.**



**Work on electrical systems and components must only be carried out by a qualified electrician.**

GB

If the potential-free contact is used, the cable must be run as shown in fig. 6.

Procedure:

1. Remove the screw holding the motor cover in place (pos. 2) and lift off the cover, see fig. 8.
2. Remove all cable connections between pressure switch 1 (pos. 9) and pressure switch 2 (pos. 10), see fig. 8.
3. Remove the buzzer (pos. 22).
4. Connect the brown supply cable lead to terminal 3 on pressure switch 1.
5. Connect the blue supply cable lead to the motor terminal.
6. Connect the black leads with flat plugs to terminals 1 and 3 on pressure switch 2 (the leads are not supplied with the lifting station).
7. Attach the black leads with the strain-relief. The strain-relief and sheet metal screws are included in the mounting kit.
8. Fit the motor cover and fasten it with the screw.

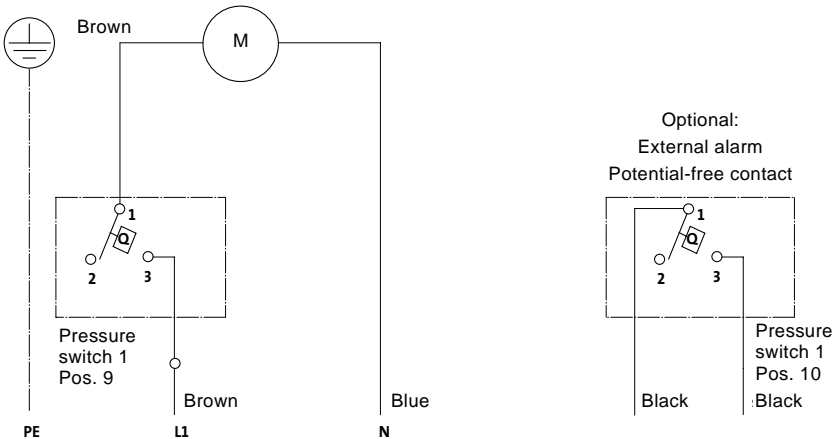

Fig. 6 Wiring diagram

TM02 7501 3603

## 6. Electrical connection

The electrical connection must be carried out by a qualified electrician in accordance with local regulations.

GB



**Before starting work on the Conlift or moving the Conlift, the electricity supply must be switched off. It must be ensured that the electricity supply cannot be accidentally switched on.**

Caution

**Make sure that the supply voltage and frequency correspond to the values stated on the nameplate.**

**As a precaution, the Conlift must be connected to a Schuko socket or a socket with earth connection. It is recommended to fit the permanent installation with an earth leakage circuit breaker (ELCB) with a tripping current < 30 mA.**



**The Conlift must be connected to an external mains switch with a minimum contact gap of 3 mm in all poles.**

- Distance from the Conlift: 1 to 1.5 metres.
- The Schuko socket/socket with earth connection and the boiler or cooling/air-conditioning system must be connected to two different circuits. In case of supply failure or undesired cut-out of the cooling/air-conditioning system, this ensures that the condensate, which continues to flow into the collecting tank, is pumped away, thus causing no damage.
- The Conlift incorporates a thermal switch, which stops the motor in case of overload. When the motor has cooled to normal temperature, it will restart automatically.

As standard, the Conlift is fitted with an alarm device (buzzer). It is also possible to pass on the alarm indication via a potential-free contact. See section 5.4.3 *External alarm/potential-free contact*.

## 7. Start-up

Note

**Start-up of the Conlift must be made in accordance with local regulations and accepted codes of good practice.**

1. Make sure that all hoses and connections are tight.
2. Make sure that the motor cover (pos. 2) is screwed on the Conlift, see section 9. *Components*.
3. Switch on the electricity supply.

## 7.1 Checking the function

### Pump operation:

Procedure:

1. Cut off the flow of condensate from the boiler or cooling/air-conditioning system, or stop the flow of condensate to the Conlift.
2. Pour the liquid of the collecting tank into a suitable container.
3. Pull the inlet hose out of the collecting tank.

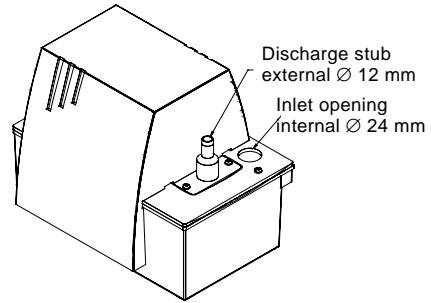

TM02 7502 3603

Fig. 7 Discharge stub and inlet opening

4. Pour approx. 1.7 litres of water into the collecting tank through the inlet opening until the start level is reached and the pump is started via pressure switch 1.
5. Stop pouring water into the tank. When the stop level is reached, the pump must stop. For stop/start/alarm levels, see fig. 1, section 4. *Function*.

### Alarm:

Continue the procedure:

6. To ensure that the alarm level is reached, squeeze the discharge hose (or close the isolating cock, if any), and pour approx. 1.5 litres of water into the collecting tank. The pump is started via pressure switch 1.
7. Continue to pour water into the tank until the alarm pressure switch (pressure switch 2) cuts out. The buzzer is activated.

Caution

**The alarm pressure switch must release the alarm (buzzer) before the water starts to run out of the Conlift.**

For stop/start/alarm levels, see fig. 1, section 4. *Function*.

8. Stop pouring water into the tank and stop squeezing the discharge hose. The alarm (buzzer) stops. The pump continues to run. When the stop level is reached, the pump stops.

The release of the alarm (buzzer) ensures that the second cut-in of the pump is effected by the alarm pressure switch (pressure switch 2), see also section 4. *Function*.

The Conlift is now ready for operation.

After having checked the function, insert the inlet hose into the collecting tank and allow the condensate from the boiler or cooling/air-conditioning system to flow into the tank.

## 8. Maintenance and service



***Before starting work on the Conlift, the electricity supply must be switched off. It must be ensured that the electricity supply cannot be accidentally switched on.***



***Condensates from boilers contain acid! If acid comes into contact with the skin or the eyes, it may cause irreversible damage.***

As the Conlift is used for different applications, different types of contamination may occur, such as lime incrustations, algae, dust on cooling/air-conditioning system, or contamination caused by acid in the boiler.

It is recommended to clean the Conlift regularly to ensure reliable operation and maximum pump performance.

### 8.1 Cleaning the Conlift

Procedure:

1. Cut off the flow of condensate from the boiler or cooling/air-conditioning system, or stop the flow of condensate to the Conlift.
2. Make sure that the hoses are not mechanically or chemically damaged.
3. Remove the inlet hose. The condensate running out of the hose must be collected in a suitable container.
4. Remove the Conlift from wall or floor.
5. Remove the motor cover.
6. Pour the entire contents of the collecting tank into a suitable container.
7. Remove the screws for the collecting tank cover (pos. 3), see fig. 8, and lift off the cover. Remove the screws in the pump housing (pos. 4) and remove the pump housing.
8. Remove deposits, dirt, algae and incrustations with a damp cloth.
9. Remove the screws holding the discharge stub in place, and remove the discharge stub and non-return valve ball.
10. Also remove deposits, dirt, algae and incrustations from the radial seal (pos. 14) with a damp cloth.
11. Assemble the Conlift in the reverse order.
12. For start-up, see section 7.

### 8.2 Contaminated lifting station or components

If a Conlift lifting station has been used for a liquid that is injurious to health or toxic, the lifting station is classified as contaminated.

If Grundfos is requested to service a contaminated lifting station, Grundfos must be contacted with details about the pumped liquid, etc. *before* the lifting station is returned for service. Otherwise Grundfos can refuse to accept the lifting station for service.

However, any application for service (no matter to whom it may be made) must include details about the pumped liquid, if the lifting station has been used for liquids that are injurious to health or toxic.

Before a lifting station is returned, it must be cleaned in the best possible way.

Possible costs of returning the lifting station are paid by the customer.

GB

# 9. Components

GB

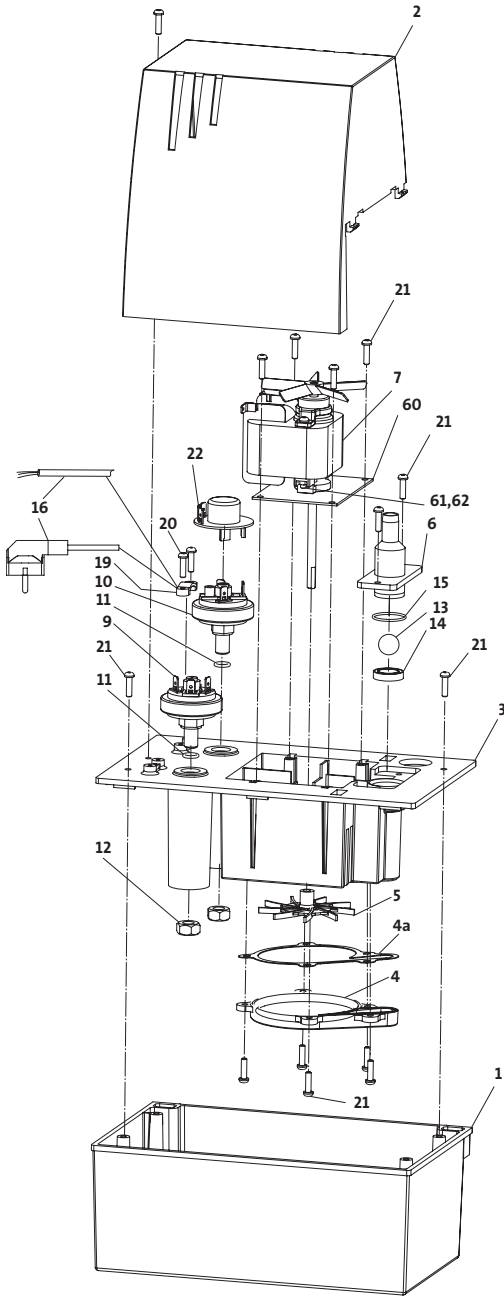

Supplied with the unit	
Pos. 51 1 x	
Pos. 52 2 x	
Pos. 53 4 x	
Pos. 54 4 x	
Pos. 55 1 x	
Pos. 56 4 x	
Pos. 19 1 x	
Pos. 20 2 x	

Fig. 8 Exploded view

## 9.1 Service kit

### 9.1.1 Mounting kit

Service kit		No. 96115902	
Pos. no.	Quantity	Description	DIN, grade, remarks
51	1	Hose, 5 metres	
52	2	Angular mounting bracket	ABS/black
53	4	Wood screw	DIN 96 4 x 35, galvanised steel
54	4	Rawlplug®	S5-5 x 25 mm, PA
55	1	Hose clamp	Black
56	4	Mounting foot	Transparent
19	1	Strain-relief	
20	2	Sheet metal screw	DIN 7981/3.9 x 13-C-H

**GB**

### 9.1.2 Discharge connection

Service kit		No. 96115903	
Pos. no.	Quantity	Description	DIN, grade, remarks
6	1	Discharge stub	ABS/black
13	1	Ball	EPDM, polished
14	1	Radial seal	EPDM WAO
15	1	O-ring	EPDM/70 SH
51	1	Hose, 5 metres	PVC, Ø 10/14 mm
55	1	Hose clamp	Black

### 9.1.3 Pressure switch

Service kit		No. 96115904	
Pos. no.	Quantity	Description	DIN, grade, remarks
9	1	Pressure switch, type 911.10	
11	1	O-ring	NBR 70 SH, 8 x 2
12	1	SKT nut	DIN 934, M110 x 1

### 9.1.4 Alarm pressure switch

Service kit		No. 96115905	
Pos. no.	Quantity	Description	DIN, grade, remarks
10	1	Pressure switch, type 911.10111X4	
11	1	O-ring	NBR 70 SH, 8 x 2
12	1	SKT nut	

### 9.1.5 Pump part

Service kit		No. 96115906	
Pos. no.	Quantity	Description	DIN, grade, remarks
4	1	Pump housing	ABS/black
4a	1	Gasket	EPDM/black
5	1	Impeller	Hostaform®
21	5	EJOT-PT screw	WN 1412, KA 40 x 16

### 9.1.6 Supply cable with Schuko plug

Service kit		No. 96115907	
Pos. no.	Quantity	Description	DIN, grade, remarks
16	1	Supply cable with Schuko plug, 2 metres	H0 5VV-F3G 0.75
19	1	Strain-relief	
20	2	Sheet metal screw	DIN 7981/3.9 x 13-C-H

### 9.1.7 Supply cable with free cable end

Service kit		No. 96115913	
Pos. no.	Quantity	Description	DIN, grade, remarks
16	1	Supply cable with free cable end, 2 metres	H0 5VV-F3G 0.75
19	1	Strain-relief	
20	2	Sheet metal screw	DIN 7981/3.9 x 13-C-H

### 9.1.8 Motor part

Service kit		No. 96115908	
Pos. no.	Quantity	Description	DIN, grade, remarks
7	1	Motor	EB 30 MVL
60	1	Motor plate MVL	BI 1.5
21	5	EJOT-PT screw	WN 1412, KA 40 x 16
4	1	Pump housing	ABS/black
4a	1	Gasket	EPDM/black
5	1	Impeller	Hostaform®
61	2	Cross-recessed raised countersunk head screw	M4 x 8
62	2	Spring washer	DIN 137

### 9.1.9 Motor cover

Service kit		No. 96115909	
Pos. no.	Quantity	Description	DIN, grade, remarks
2	1	Cover	ABS/black
21	1	EJOT-PT screw	WN 1412, KA 40 x 16

### 9.1.10 Collecting tank

Service kit		No. 96115910	
Pos. no.	Quantity	Description	DIN, grade, remarks
1	1	Collecting tank	ABS/black
3	1	Tank cover	ABS/black
52	2	Angular mounting bracket	ABS/black
53	2	Wood screw	DIN 96 4 x 35, galvanised steel
54	2	Rawlplug®	S5-5 x 25 mm, PA
55	1	Hose clamp	Black
56	4	Mounting foot	Transparent
21	2	EJOT-PT screw	WN 1412, KA 40 x 16

**GB**

### 9.1.11 PC-board

Service kit		No. 96115901	
Pos. no.	Quantity	Description	DIN, grade, remarks
22	1	PC-board with buzzer for pressure switch	

## 9.2 Accessories

The following accessories for the Conlift are available from a local supplier.

Accessory no.	Description	Product number
1	5 metres of PVC hose with 10 mm internal diameter including 1 hose coupling and 2 clamps	96115911
2	1 isolating cock with 10 mm internal diameter including 2 clamps	96115912

## 10. Fault finding chart



**Before starting the fault finding, the electricity supply must be switched off. It must be ensured that the electricity supply cannot be accidentally switched on.**

**Work on electrical systems and components must only be carried out by a qualified electrician.**

GB

Fault	Cause	Remedy
1. The pump does not run.	a) No electricity supply.	Switch on the electricity supply.
	b) Fuse is blown.	Check the electrical connection.
		Fuse too small. - Check the performance data.
	Replace the fuse.	
c) Supply cable damaged.	The cable must be repaired or replaced by an authorized service workshop or by Grundfos.	
	d) Thermal switch cut out.	The motor is not sufficiently cooled. - The cooling slots in the motor cover are covered or clogged.
		Deposits in the pump part. - Clean the impeller, pump housing and entire lifting station.
		The condensate is not discharged through the discharge hose. - See fault, point 2.
Pump does not start and stop according to S3 operation. - See section 11. <i>Technical data</i> .		
2. Lower or no performance.	a) Discharge hose squeezed or broken.	Check the discharge hose.
		The bending radius of the hose must be at least 60 mm.
	b) The non-return valve does not open.	Remove the discharge stub, and clean ball and seal.
c) The motor fan cannot rotate freely.	Clean the pump housing and impeller.	
3. Frequent starts and stops.	a) Non-return valve does not close properly.	Remove the discharge stub, and clean ball and seal. Replace the radial seal (pos. 14), if required.
	b) The inlet quantity is too large.	Check the inlet quantity.
4. Alarm.	a) The condensate is not pumped out of the tank.	See faults, points 2 and 3.

**Note:** Components must only be replaced by a qualified person.

## 11. Technical data

### Supply voltage

1 x 230 V ± 10 %, 50 Hz, PE.

See nameplate.

### Input power

P1 = 80 W.

### Input current

I = 0.7 A.

### Back-up fuse

10 A slow-blowing fuse on the mains side and earth leakage circuit breaker according to IEC 345.

### Buzzer

- Sound pressure level: 80 dB(A).
- Control voltage: 230 V.

### Head

Maximum 5.4 metres (tolerance ±10 % at +20 °C).

### Flow rate

Maximum 630 l/h (tolerance ±10 % at +20 °C).

### Liquid temperature

- 0 °C to +35 °C.
- For short periods: Maximum +80 °C for 1 minute.

### Ambient temperature

During operation: 0 °C.

In stock:

- In dry rooms frost-proof down to -20 °C.
- Lifting stations containing condensate:  
In dry rooms with a temperature above 0 °C.  
(There must be no risk of frost.)

### pH value

2.7 or above.

### Maximum density

1000 kg/m<sup>3</sup>.

### Operating mode

Intermittent operation, S3: 15 % according to DIN EN 0530 T1 (i.e. runs for 1.5 minutes and is stopped for 8.5 minutes).

### Motor protection

- Thermal switch: +120 °C.
- Insulation class: B.

### Potential-free contact

- Changeover switch.
- Breaking capacity: 6 (1.5) A 250 VAC.
- Connections: Flat plugs 6.3 x 0.8.

### Enclosure class

IP X4.

## Dimensions

- Tank volume: 2.6 litres.
- Storage volume: 0.85 litre.
- H x L x B = 199 x 245 x 171 mm.  
See also dimensional sketch, fig. 2.

## Weight

2.3 kg.

## 11.1 Other technical data

See nameplate.

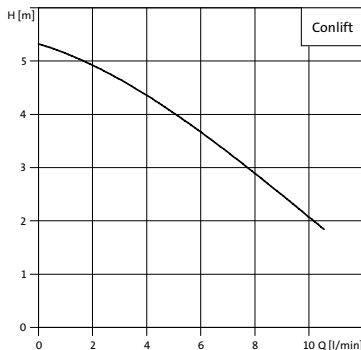

**Fig. 9** Performance curve

TM02 7446 1204

## 12. Disposal

This product or parts of it must be disposed of in an environmentally sound way:

1. Use the public or private waste collection service.
2. If this is not possible, contact the nearest Grundfos company or service workshop.

**Argentina**

Bombas GRUNDFOS de Argentina S.A.  
Ruta Panamericana km. 37.500 Lote 34A  
1619 - Garin  
Pcia. de Buenos Aires  
Phone: +54-3327 414 444  
Telefax: +54-3327 411 111

**Australia**

GRUNDFOS Pumps Pty. Ltd.  
P.O. Box 2040  
Regency Park  
South Australia 5942  
Phone: +61-8-8461-4611  
Telefax: +61-8-8340 0155

**Austria**

GRUNDFOS Pumpen Vertrieb Ges.m.b.H.  
Grundfosstraße 2  
A-5082 Grödig/Salzburg  
Tel.: +43-6246-883-0  
Telefax: +43-6246-883-30

**Belgium**

N.V. GRUNDFOS Bellux S.A.  
Boomssteenvweg 81-83  
B-2630 Aartselaar  
Tél.: +32-3-870 7300  
Telefax: +32-3-870 7301

**Belorussia**

Представительство ГРУНДФОС в  
Минске  
220090 Минск ул.Олешева 14  
Телефон: (8632) 62-40-49  
Факс: (8632) 62-40-49

**Bosnia/Herzegovina**

GRUNDFOS Sarajevo  
Paromlinska br. 16,  
BIH-71000 Sarajevo  
Phone: +387 33 713290  
Telefax: +387 33 231795

**Brazil**

Mark GRUNDFOS Ltda.  
Av. Humberto de Alencar Castelo Branco,  
630  
CEP 09850 - 300  
São Bernardo do Campo - SP  
Phone: +55-11 4393 5533  
Telefax: +55-11 4343 5015

**Bulgaria**

GRUNDFOS Pumpen Vertrieb  
Representative Office - Bulgaria  
Bulgaria, 1421 Sofia  
Loznetz District  
105-107 Arsenalski Blvd.  
Phone: +359 2963 3820, 2963 5653  
Telefax: +359 2963 1305

**Canada**

GRUNDFOS Canada Inc.  
2941 Brighton Road  
Oakville, Ontario  
L6H 6C9  
Phone: +1-905 829 9533  
Telefax: +1-905 829 9512

**China**

GRUNDFOS Pumps (Shanghai) Co. Ltd.  
51 Floor, Raffles City  
No. 268 Xi Zang Road. (M)  
Shanghai 200001  
PRC  
Phone: +86-021-612 252 22  
Telefax: +86-021-612 253 33

**Croatia**

GRUNDFOS predstavništvo Zagreb  
Cebini 37, Buzin  
HR-10000 Zagreb  
Phone: +385 1 6595 400  
Telefax: +385 1 6595 499

**Czech Republic**

GRUNDFOS s.r.o.  
Čajkovského 21  
779 00 Olomouc  
Phone: +420-585-716 111  
Telefax: +420-585-716 299

**Denmark**

GRUNDFOS DK A/S  
Martin Bachs Vej 3  
DK-8850 Bjerringbro  
Tlf.: +45-87 50 50 50  
Telefax: +45-87 50 51 51  
E-mail: info\_GDK@grundfos.com  
www.grundfos.com/DK

**Estonia**

GRUNDFOS Pumps Eesti OU  
Peterburi tee 92G  
11415 Tallinn  
Tel: + 372 606 1690  
Fax: + 372 606 1691

**Finland**

OY GRUNDFOS Pumput AB  
Mestarientie 11  
FIN-01730 Vantaa  
Phone: +358-3066 5650  
Telefax: +358-3066 5650

**France**

Pompes GRUNDFOS Distribution S.A.  
Parc d'Activités de Chenes  
57, rue de Malacombe  
F-38290 St. Quentin Fallavier (Lyon)  
Tél.: +33-4 74 82 15 15  
Télecoipe: +33-4 74 94 10 51

**Germany**

GRUNDFOS GMBH  
Schlüterstr. 33  
40699 Erkrath  
Tel.: +49-021 121 929 69-0  
Telefax: +49-021 121 929 69-3799  
e-mail: info:service@grundfos.de  
Service in Deutschland:  
e-mail: kundendienst@grundfos.de

**Greece**

GRUNDFOS Hellas A.E.B.E.  
20th km. Athinon-Markopoulou Av.  
P.O. Box 71  
GR-19002 Peania  
Phone: +0030-210-66 83 400  
Telefax: +0030-210-66 46 273

**Hong Kong**

GRUNDFOS Pumps (Hong Kong) Ltd.  
Unit 1, Ground floor  
Siu Wai Industrial Centre  
29-33 Wing Hong Street &  
68 King Lam Street, Cheung Sha Wan  
Kowloon  
Phone: +852-27861706 / 27861741  
Telefax: +852-27858664

**Hungary**

GRUNDFOS Hungaria Kft.  
Park u. 8  
H-2045 Törökbalánt,  
Phone: +36-23 511 110  
Telefax: +36-23 511 111

**India**

GRUNDFOS Pumps India Private Limited  
118 Old Mahabaliapuram Road  
Thoraipakkam  
Chennai 600 096  
Phone: +91-44 2496 6800

**Indonesia**

PT GRUNDFOS Pompa  
Jl. Rawa Sumur III, Blok III / CC-1  
Kawasan Industri, Pulogadung  
Jakarta 13930  
Phone: +62-21-460 6909  
Telefax: +62-21-460 6910 / 460 6901

**Ireland**

GRUNDFOS (Ireland) Ltd.  
Unit A, Merrywell Business Park  
Ballymount Road Lower  
Dublin 12  
Phone: +353-1-4089 800  
Telefax: +353-1-4089 830

**Italy**

GRUNDFOS Pompe Italia S.r.l.  
Via Gran Sasso 4  
I-20060 Trussuzzano (Milano)  
Tel.: +39-02-95838112  
Telefax: +39-02-95309290 / 95838461

**Japan**

GRUNDFOS Pumps K.K.  
Gotanda Metalon Bldg., 5F,  
5-21-15, Higashi-gotanda  
Shiagawa-ku, Tokyo  
141-0022 Japan  
Phone: +81 35 448 1391  
Telefax: +81 35 448 9619

**Korea**

GRUNDFOS Pumps Korea Ltd.  
6th Floor, Aju Building 679-5  
Yeoksam-dong, Kangnam-ku, 135-916  
Seoul, Korea  
Phone: +82-2-5317 600  
Telefax: +82-2-5633 725

**Latvia**

SIA GRUNDFOS Pumps Latvia  
Deglava biznesa centrs  
Augusta Deglava iela 60, LV-1035, Rīga,  
Tālr.: + 371 714 9640, 7 149 641  
Fakss: + 371 914 9646

**Lithuania**

GRUNDFOS Pumps UAB  
Smolensko g. 6  
LT-03201 Vilnius  
Tel.: + 370 52 395 430  
Fax: + 370 52 395 431

**Malaysia**

GRUNDFOS Pumps Sdn. Bhd.  
7 Jalan Peguam U1/25  
Glenmarie Industrial Park  
40150 Shah Alam  
Selangor  
Phone: +60-3-5569 2922  
Telefax: +60-3-5569 2866

**México**

Bombas GRUNDFOS de México S.A. de  
C.V.  
Boulevard TLC No. 15  
Parque Industrial Stiva Aeropuerto  
Apodaca, N.L. 66600  
Phone: +52-81-8144 4000  
Telefax: +52-81-8144 4010

**Netherlands**

GRUNDFOS Netherlands  
Veluwezoom 35  
1326 AE Almere  
Postbus 22015  
1302 CA ALMERE  
Tel.: +31-88-478 6336  
Telefax: +31-88-478 6332  
e-mail: info\_gnl@grundfos.com

**New Zealand**

GRUNDFOS Pumps NZ Ltd.  
17 Beatrice Tinsley Crescent  
North Harbour Industrial Estate  
Albany, Auckland  
Phone: +64-9-415 3240  
Telefax: +64-9-415 3250

**Norway**

GRUNDFOS Pumper A/S  
Strømsveien 34L  
Postboks 235, Leirdal  
N-1011 Oslo  
Tlf.: +47-22 90 47 00  
Telefax: +47-22 32 21 50

**Poland**

GRUNDFOS Pompy Sp. z o.o.  
ul. Klonowa 23  
Baranowo k. Poznania  
PL-62-081 Przeźmierowo  
Tel: (+48-61) 650 13 50  
Fax: (+48-61) 650 13 50

**Portugal**

Bombas GRUNDFOS Portugal, S.A.  
Rua Calvet de Magalhães, 241  
Apartado 1079  
P-2770-153 Paços de Arcos  
Tel.: +351-21-440 76 00  
Telefax: +351-21-440 76 90

**România**

GRUNDFOS Pompe România SRL  
Bd. Biruintei, nr 103  
Pantelimon county Ifov  
Phone: +40 21 200 4100  
Telefax: +40 21 200 4101  
E-mail: romania@grundfos.ro  
OOO ГРУНДФОС  
Россия, 109544 Москва, ул. Школьная 39  
Тел. (+7) 495 737 30 00, 564 88 00  
Факс (+7) 495 737 75 36, 564 88 11  
E-mail grundfos.moscow@grundfos.com

**Serbia**

GRUNDFOS Predstavništvo Beograd  
Dr. Milutina Ivkovića 2a/29  
YU-11000 Beograd  
Phone: +381 11 26 47 877 / 11 26 47 496  
Telefax: +381 11 26 48 340

**Singapore**

GRUNDFOS (Singapore) Pte. Ltd.  
24 Tuas West Road  
Jurong Town  
Singapore 638381  
Phone: +65-6865 1222  
Telefax: +65-6861 8402

**Slovenia**

GRUNDFOS PUMPEN VERTRIEB  
Ges.m.b.H.,  
Podružnica Ljubljana  
Biatnica 1, SI-1236 Trzin  
Phone: +386 1 563 5338  
Telefax: +386 1 563 2098  
E-mail: slovenia@grundfos.si

**Spain**

Bombas GRUNDFOS España S.A.  
Camino de la Fuenteclia, s/n  
E-28110 Algete (Madrid, s/r)  
Tel.: +34-91-848 8800  
Telefax: +34-91-628 0465

**Sweden**

GRUNDFOS AB  
Box 333 (Lunnagårsgatan 6)  
431 24 Mölndal  
Tel.: +46(0)771-32 23 00  
Telefax: +46(0)31-331 94 60

**Switzerland**

GRUNDFOS Pumpen AG  
Bruggacherstrasse 10  
CH-8117 Fallanden/ZH  
Tel.: +41-1-806 8111  
Telefax: +41-1-806 8115

**Taiwan**

GRUNDFOS Pumps (Taiwan) Ltd.  
7 Floor, 218 Min-Chuan Road  
Taichung, Taiwan, R.O.C.  
Phone: +886-4-2305 0860  
Telefax: +886-4-2305 0878

**Thailand**

GRUNDFOS (Thailand) Ltd.  
92 Chaloem Phrakiat Rama 9 Road,  
Dokmai, Pravej, Bangkok 10250  
Phone: +66-2-725 8999  
Telefax: +66-2-725 8998

**Turkey**

GRUNDFOS POMPA San. ve Tic. Ltd. Sti.  
Gezbe Organize Sanayi Bölgesi  
Ihsan dede Caddesi,  
2. yol 200. Sokak No. 204  
14190 Gebze/ Kocaeli  
Phone: +90 - 262-679 7979  
Telefax: +90 - 262-679 7905  
E-mail: sats@grundfos.com

**Ukraine**

ТОВ ГРУНДФОС УКРАЇНА  
01010 Київ, Вул. Московська 86,  
Тел.: (+38 044) 390 40 50  
Факс: (+38 044) 390 40 59  
E-mail: ukraine@grundfos.com

**United Arab Emirates**

GRUNDFOS Gulf Distribution  
P.O. Box 16768  
Jebel Ali Free Zone  
Dubai  
Phone: +971-4- 8815 166  
Telefax: +971-4-8815 136

**United Kingdom**

GRUNDFOS Pumps Ltd.  
Grovebury Road  
Leighton Buzzard/Beds, LU7 8TL  
Phone: +44-1525-850000  
Telefax: +44-1525-850011

**U.S.A.**

GRUNDFOS Pumps Corporation  
17100 West 118th Terrace  
Olathe, Kansas 66061  
Phone: +1-913-227-3400  
Telefax: +1-913-227-3500

**Usbekistan**

Представительство ГРУНДФОС в  
Ташкенте  
700000 Ташкент ул.Усмана Носира 1-й  
тулик 5  
Телефон: (3712) 55-66-15  
Факс: (3712) 53-36-35

<b>96521370</b> 0508	<b>226</b>
Repl. 96521370 0406	