

CHIE

Frequency-controlled horizontal, multistage, centrifugal pumps
50/60 Hz



Contents

Product data

| | | |
|---|------|---|
| Performance range, 2900 min ⁻¹ | Page | 3 |
| Performance range, 3450 min ⁻¹ | Page | 3 |
| CHIE | Page | 4 |
| Product range, 2900 min ⁻¹ | Page | 5 |
| Product range, 3450 min ⁻¹ | Page | 5 |
| Type keys | Page | 5 |
| Codes | Page | 6 |
| Applications | Page | 6 |
| Pumped liquids | Page | 6 |
| Operating conditions | Page | 6 |
| Shaft seal | Page | 6 |
| Pump | Page | 7 |
| Materials | Page | 7 |
| Sectional drawing | Page | 7 |

Applications

| | | |
|--------------------------|------|---|
| Examples of applications | Page | 8 |
|--------------------------|------|---|

Functions

| | | |
|-----------------------------------|------|----|
| Overview of functions | Page | 10 |
| Operating modes | Page | 11 |
| Control panel | Page | 12 |
| Setting by means of R100 | Page | 13 |
| Menu OPERATION | Page | 14 |
| Menu STATUS | Page | 14 |
| Menu INSTALLATION | Page | 15 |
| External forced-control signals | Page | 17 |
| External setpoint signal | Page | 17 |
| Indicator lights and signal relay | Page | 18 |

Installation

| | | |
|------------------------|------|----|
| Introduction | Page | 19 |
| Electrical connection | Page | 19 |
| Other connections | Page | 20 |
| Cables | Page | 20 |
| External force control | Page | 20 |
| Performance curves | Page | 21 |
| Curve conditions | Page | 21 |

Performance curves/ Technical data

| | | |
|--|------|----|
| Performance curves, 2900 min ⁻¹ | Page | 22 |
| Performance curves, 3450 min ⁻¹ | Page | 25 |
| Dimensional drawing | Page | 28 |
| Dimensions and weights, 2900 min ⁻¹ | Page | 28 |
| Dimensions and weights, 3450 min ⁻¹ | Page | 28 |

Technical data

| | | |
|-----------------|------|----|
| Electrical data | Page | 29 |
|-----------------|------|----|

Accessories

| | | |
|-------------------|------|----|
| Sensors | Page | 30 |
| Potentiometer | Page | 31 |
| R100 | Page | 31 |
| G10-LON interface | Page | 31 |

Performance range, 2900 min⁻¹

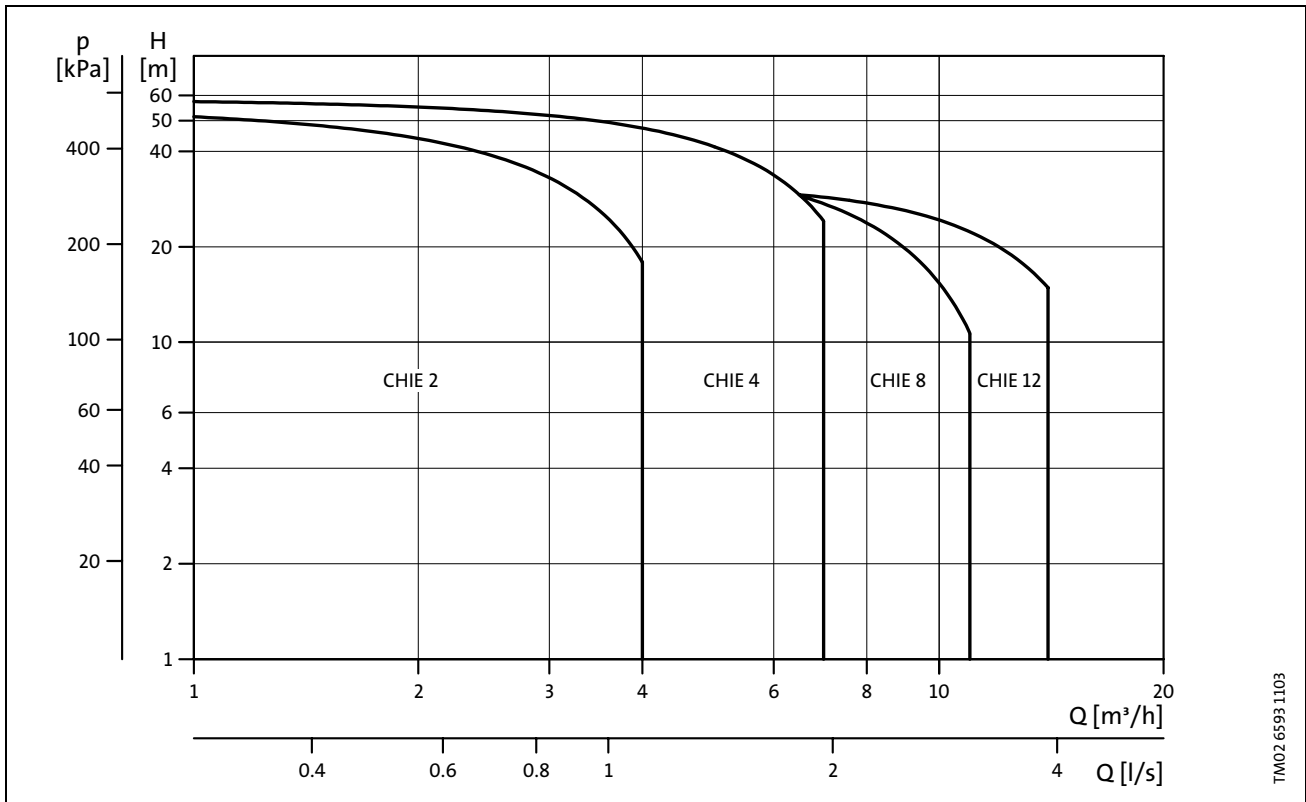

Performance range, 3450 min⁻¹

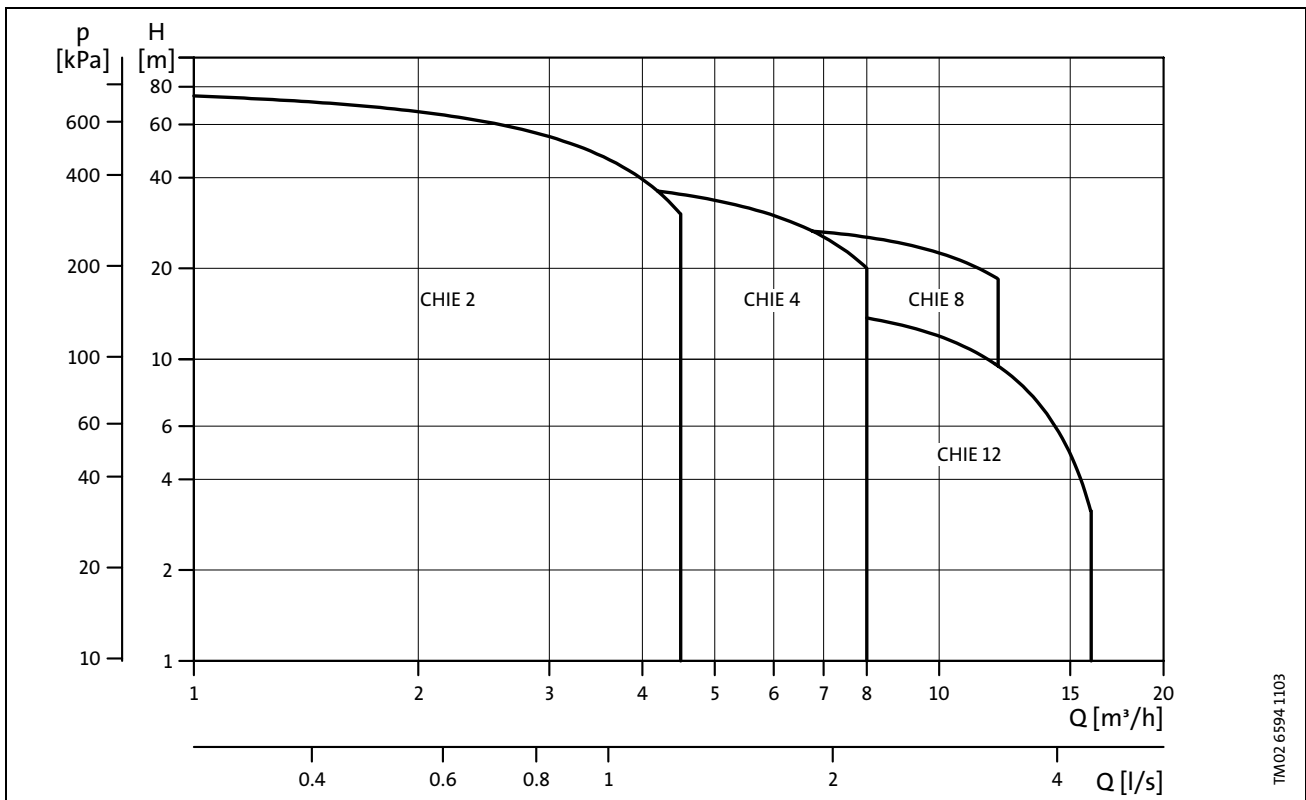

CHIE

CHIE is a unique product combining

- stainless steel for all parts in contact with the pumped liquid,
- compact design,
- MGE motor.

This makes CHIE very suitable for industrial applications requiring a stainless steel product with variable pump performance.

Through frequency control the MGE motor enables continuously variable motor speed. Thus the pump can operate in any duty point within the range between min. and max. performance curves.

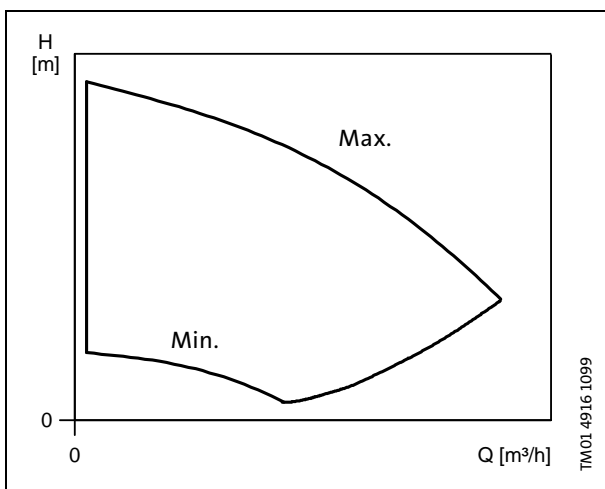

The duty point can be set on the control panel of the CHIE pump terminal box or via the Grundfos R100 remote control. For further information, see “Functions” on page 10.

Operating modes

CHIE can operate in controlled operating mode enabling constant pressure by means of the built-in PI-controller and a pressure sensor. For further information see figure below and page 11.

Alternatively, the pump can operate in uncontrolled operating mode enabling pump performance control via an external signal. For further information see page 11.

CHIE can work with

- differential pressure sensors,
- flow sensors,
- temperature sensors,
- differential temperature sensors.

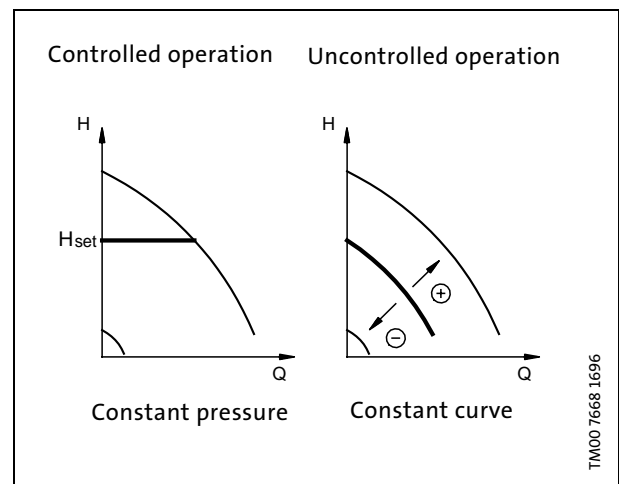

Product range

1 x 200-240 V, 50/60 Hz, 2900 min⁻¹

| Pump type | Motor P ₂ [kW] | Full load current I _{1/1} [A] | Shaft seal | | | | | |
|------------|------------------------------|--|-------------|-------------|-------------|-------------|-------------|-------------|
| | | | BQQE | BQQV | BUBE | BUBV | BUUE | BUUV |
| CHIE 2-30 | 0.37 | 3.00-2.50 | 4H 50 58 03 | 4H 51 58 03 | 4H 55 58 03 | 4H 56 58 03 | 4H 57 58 03 | 4H 58 58 03 |
| CHIE 2-50 | 0.55 | 4.30-3.60 | 4H 50 58 05 | 4H 51 58 05 | 4H 55 58 05 | 4H 56 58 05 | 4H 57 58 05 | 4H 58 58 05 |
| CHIE 2-60 | 0.75 | 5.60-4.70 | 4H 50 58 06 | 4H 51 58 06 | 4H 55 58 06 | 4H 56 58 06 | 4H 57 58 06 | 4H 58 58 06 |
| CHIE 4-10 | 0.37 | 3.00-2.50 | 4J 50 58 01 | 4J 51 58 01 | 4J 55 58 01 | 4J 56 58 01 | 4J 57 58 01 | 4J 58 58 01 |
| CHIE 4-30 | 0.55 | 4.30-3.60 | 4J 50 58 03 | 4J 51 58 03 | 4J 55 58 03 | 4J 56 58 03 | 4J 57 58 03 | 4J 58 58 03 |
| CHIE 4-40 | 0.75 | 5.60-4.70 | 4J 50 58 04 | 4J 51 58 04 | 4J 55 58 04 | 4J 56 58 04 | 4J 57 58 04 | 4J 58 58 04 |
| CHIE 4-60 | 1.1 | 8.20-6.80 | 4J 50 58 06 | 4J 51 58 06 | 4J 55 58 06 | 4J 56 58 06 | 4J 57 58 06 | 4J 58 58 06 |
| CHIE 8-10 | 0.55 | 4.30-3.60 | 4E 50 58 10 | 4E 51 58 10 | 4E 55 58 10 | 4E 56 58 10 | 4E 57 58 10 | 4E 58 58 10 |
| CHIE 8-20S | 0.75 | 5.60-4.70 | 4E 50 58 12 | 4E 51 58 12 | 4E 55 58 12 | 4E 56 58 12 | 4E 57 58 12 | 4E 58 58 12 |
| CHIE 8-20 | 1.1 | 8.20-6.80 | 4E 50 58 20 | 4E 51 58 20 | 4E 55 58 20 | 4E 56 58 20 | 4E 57 58 20 | 4E 58 58 20 |
| CHIE 12-05 | 0.37 | 3.00-2.50 | 4F 50 58 05 | 4F 51 58 05 | 4F 55 58 05 | 4F 56 58 05 | 4F 57 58 05 | 4F 58 58 05 |
| CHIE 12-15 | 1.1 | 8.20-6.80 | 4F 50 58 15 | 4F 51 58 15 | 4F 55 58 15 | 4F 56 58 15 | 4F 57 58 15 | 4F 58 58 15 |

Product range

1 x 208-230 V, 50/60 Hz, 3450 min⁻¹

| Pump type | Motor P ₂ [kW] | Frame size | Shaft seal | | | | | |
|-------------|------------------------------|------------|-------------|-------------|-------------|-------------|-------------|-------------|
| | | | BQQE | BQQV | BUBE | BUBV | BUUE | BUUV |
| CHIE 2-10★ | 0.5 | 71AB | 4H 50 59 61 | 4H 51 59 61 | 4H 55 59 61 | 4H 56 59 61 | 4H 57 59 61 | 4H 58 59 61 |
| CHIE 2-30★ | 0.75 | 71 BA | 4H 50 59 63 | 4H 51 59 63 | 4H 55 59 63 | 4H 56 59 63 | 4H 57 59 63 | 4H 58 59 63 |
| CHIE 2-40★ | 1.0 | 80AA | 4H 50 59 64 | 4H 51 59 64 | 4H 55 59 64 | 4H 56 59 64 | 4H 57 59 64 | 4H 58 59 64 |
| CHIE 2-60★ | 1.5 | 80BA | 4H 50 59 66 | 4H 51 59 66 | 4H 55 59 66 | 4H 56 59 66 | 4H 57 59 66 | 4H 58 59 66 |
| CHIE 4-10★ | 0.5 | 71AB | 4J 50 59 61 | 4J 51 59 61 | 4J 55 59 61 | 4J 56 59 61 | 4J 57 59 61 | 4J 58 59 61 |
| CHIE 4-20★ | 1.0 | 80AA | 4J 50 59 62 | 4J 51 59 62 | 4J 55 59 62 | 4J 56 59 62 | 4J 57 59 62 | 4J 58 59 62 |
| CHIE 4-30★ | 1.5 | 80BA | 4J 50 59 63 | 4J 51 59 63 | 4J 55 59 63 | 4J 56 59 63 | 4J 57 59 63 | 4J 58 59 63 |
| CHIE 8-20s★ | 1.5 | 80BA | 4E 51 59 72 | 4E 51 59 72 | 4E 55 59 72 | 4E 56 59 72 | 4E 57 59 72 | 4E 58 59 72 |
| CHIE 12-05★ | 0.75 | 71BA | 4F 50 59 65 | 4F 51 59 65 | 4J 55 59 65 | 4J 56 59 65 | 4J 57 59 65 | 4J 58 59 65 |

★ The 60 Hz product range has a UL approval.

Type keys

CHIE 2 and CHIE 4

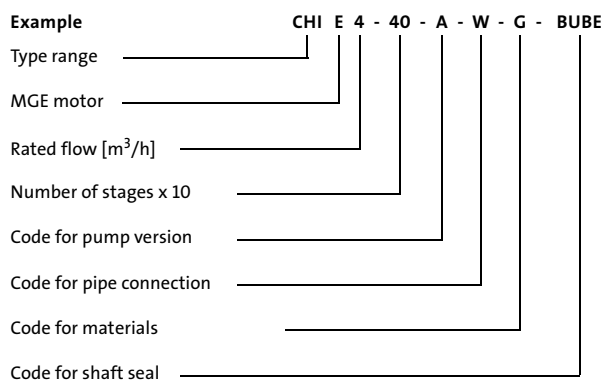

CHIE 8 and CHIE 12

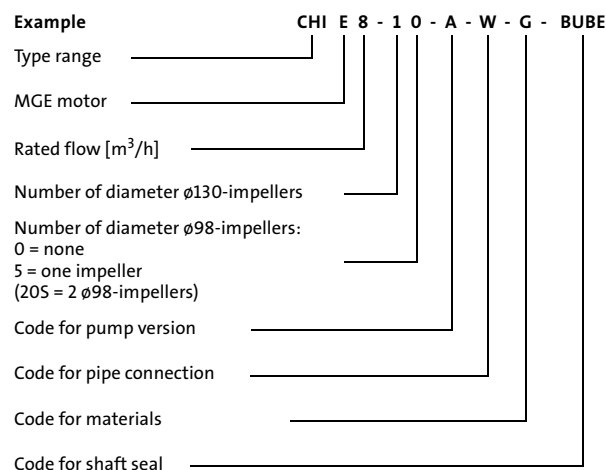

Codes

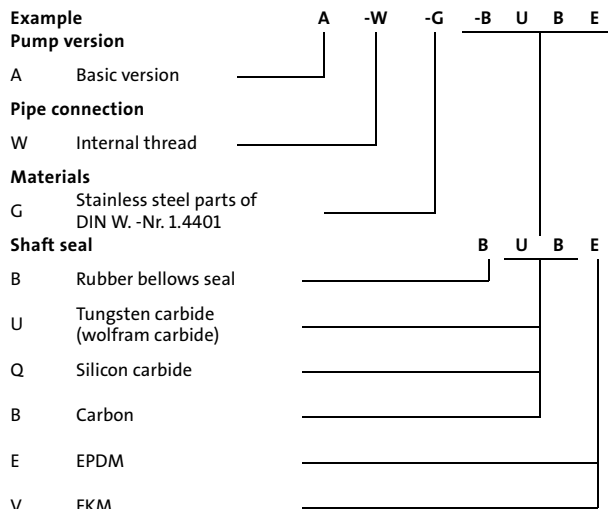

Applications

The CHIE pumps are primarily designed for

- water supply and pressure boosting (potable water, also slightly chlorinated), see example 1 on page 8,
- water treatment, see example 2 on page 8,
- industrial washing and cleaning,
- pressure boosting of process water,
- heating and cooling in industrial processes, see example 3 on page 9,
- fertilizer/dosing systems.

Pumped liquids

Thin, clean, non-aggressive and non-explosive liquids without solid particles or fibres.

The pumps can pump liquids such as demineralised water, softened water, cleaning solutions, light oils and other light chemicals.

When pumping liquids with a density and/or viscosity higher than that of water, motors with correspondingly higher outputs must be used.

Whether a pump is suitable for a particular liquid depends on a number of factors of which the most important are chloride content, pH value, temperature and content of solvents or oils, etc.

Operating conditions

Liquid temperature: -20°C to $+120^{\circ}\text{C}$
 Maximum ambient temperature: $+40^{\circ}\text{C}$
 Maximum operating pressure: 10 bar
 Sound pressure level: $< 70\text{ dB(A)}$

Inlet pressure:

Minimum inlet pressure according to the NPSH curve + a margin of 0.5 m.

Maximum inlet pressure is limited by maximum operating pressure.

Shaft seal

The shaft seal is a single, mechanical, bellows seal.

The shaft seal should be selected on the basis of liquid temperature and type of liquid.

For other liquids than water, the chemical resistance of the materials - incl. seal face, seat and rubber components of the shaft seal - must be taken into account.

The following table shows available shaft seal types.

| Shaft seal type | Material | Rubber parts |
|-----------------|---|---------------------|
| BUBE BUBV | Tungsten carbide (U)/ Carbon (B) | EPDM (E) FKM (V) |
| BQQE BQQV | Silicon carbide (Q)/ Silicon carbide (Q) | |
| BUUE BUUV | Tungsten carbide (U)/ Tungsten carbide (U) | |

The following diagrammes apply to clean water and water-containing antifreeze additives.

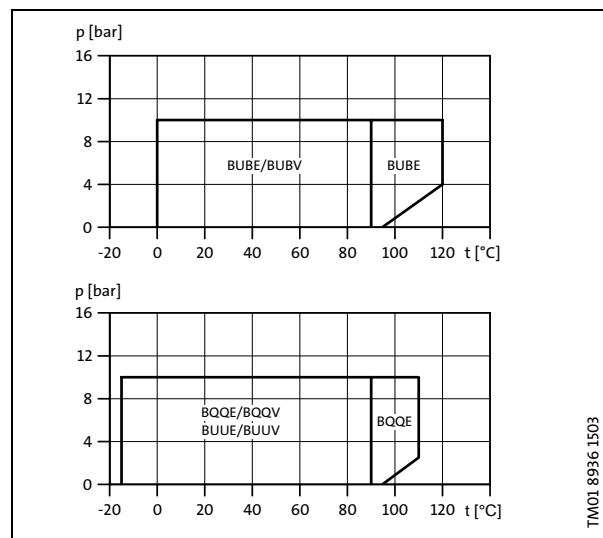

Pump

The CHIE pumps are horizontal, non-self-priming, centrifugal pumps with through-going motor/pump shaft.

All CHIE parts in contact with the pumped liquid are made of stainless steel (DIN W.-Nr. 1.4401).

All bearings are self-lubricating, i.e. they are lubricated by the pumped liquid.

The pump sleeve is of drawn steel sheet and has axial suction port and radial discharge port.

The pump sleeve has a hole for the priming plug (G 3/8) at the top and one for the drain plug (G 3/8) at the bottom.

Materials

| Pos. | Pump components | Materials | DIN W. Nr. |
|------|---------------------|-----------------|------------|
| 1 | Pump sleeve | Stainless steel | 1.4401 |
| 2 | Chamber/guide plate | Stainless steel | 1.4401 |
| 3 | Impeller | Stainless steel | 1.4401 |
| 4 | Inlet port | Stainless steel | 1.4401 |
| 5 | Spline shaft | Stainless steel | 1.4401 |
| 6 | Cover plate | Stainless steel | 1.4401 |
| 7 | Shaft seal faces | | |
| 8 | Base plate | Painted steel | 1.0338 |
| 9 | Motor stool | Silumin | |
| 10 | Ball bearing | | |
| | O-rings | EPDM or FKM | |

Sectional drawing

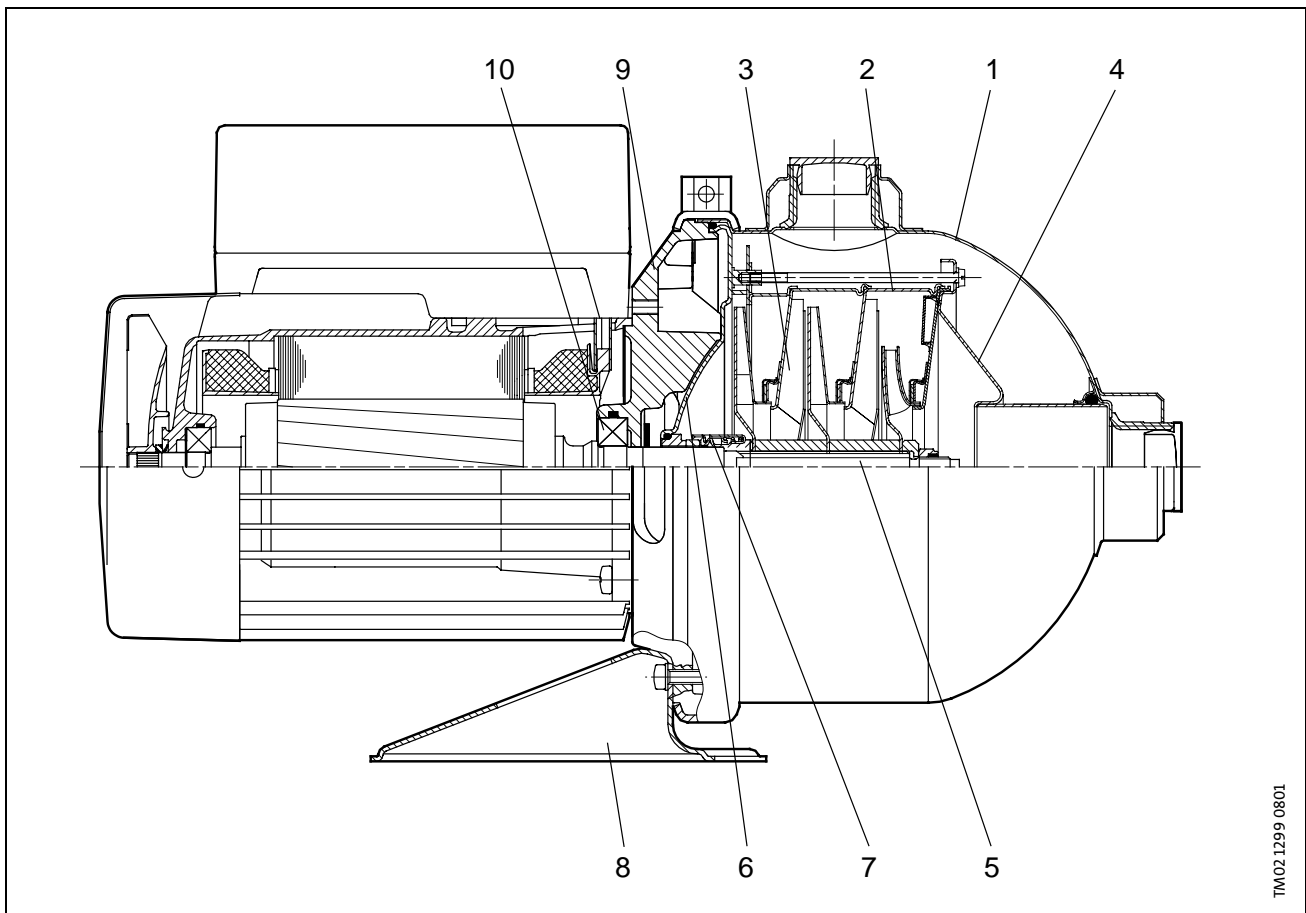

TM02.1299.0801

Examples of applications

The CHIE pumps are the ideal solution in applications characterized by a need for variable flow. The pumps are suited for water supply systems and pressure boosting, but also industrial applications such as pressure boosting in water treatment systems are obvious for this type of pumps.

Depending on the nature of the application, the pumps offer energy savings, increased comfort or improved processing.

Example 1: A compact one-pump booster

Only one CHIE, a pressure sensor and a small diaphragm tank, are required to build a compact pressure booster supplying constant pressure.

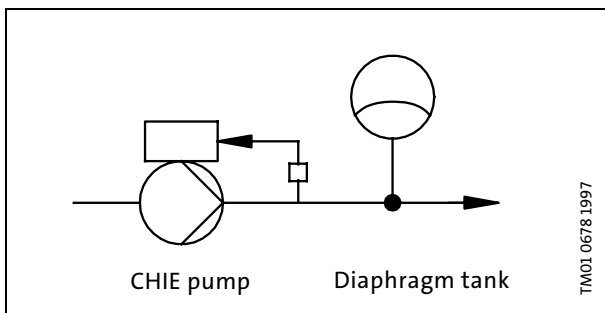

CHIE incorporates a stop function ensuring that the pump automatically stops if the water demand drops to a very low level or disappears altogether. The method gives good total operating economy irrespective of the water demand, and the pump is not subjected to overheating and the subsequent risk of damage to the shaft seal.

CHIE incorporated in bigger pressure boosting systems

If a single CHIE is not enough to meet the required pump performance, 2 to 4 CHIE pumps can be mounted in parallel in a pressure boosting system. Each pump has a non-return valve installed and the pumps are controlled by a Grundfos Control 2000 ME control unit.

The control unit measures the system discharge pressure and ensures that only the necessary number of pumps are operating and that performance is according to actual need.

Please contact Grundfos for further details concerning the Control 2000 ME.

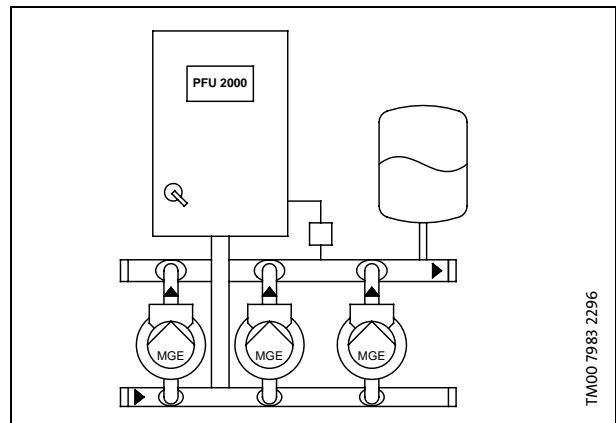

Example 2: Water treatment systems

Water treatment is an obvious area for speed-controlled CHIE pumps. Combining stainless steel materials and speed control makes it possible to meet material requirements as well as the need for optimum operating conditions, minimum energy consumption etc.

Due to the small dimensions of the CHIE pump it is suited for the pumping of clean water in compact water treatment systems.

The pump can supply the processed water at a constant pressure to the consumer.

Example 3: CHIE for optimum process cooling

Optimum process cooling can be achieved by means of

- a CHIE variable speed pump,
- a sensor to monitor system conditions,
- an R100 for remote activation and setting of operation.

With this equipment you can base operation on either differential pressure, flow or temperature. As a bonus you achieve significant energy savings and reduction of system stress and, consequently, reduced cost of ownership.

In the simple system in the figure below cooling is performed by a cooling tower. Variable pump speed and the use of a temperature sensor give these advantages:

- energy consumption is down by 50% as the pump only runs at the speed required,
- noise is reduced due to lower differential pressure,
- customised functions are integrated in one compact unit allowing for easy adjustment of settings.

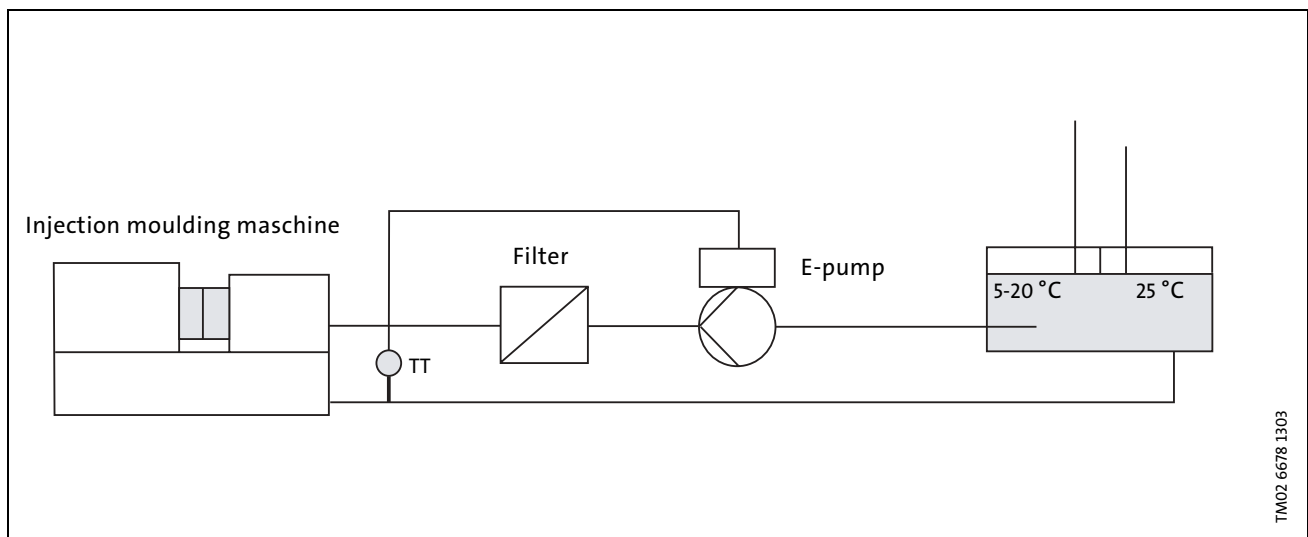

Background

Cooling systems with varying performance requirements are often used in industrial processes such as casting and machining. A cooling system consists of a primary and a secondary circuit.

The two circuits are isolated from each other by a heat exchanger.

The primary circuit leads the liquid to be cooled in a constant flow through a cooling unit such as a cooling tower. The secondary circuit leads the cooling liquid through the machine to be cooled. As the cooling requirement varies so does the flow in the secondary circuit.

Overview of functions

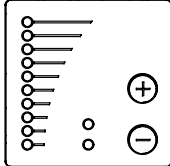
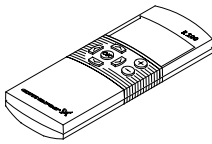
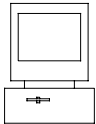
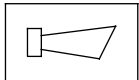
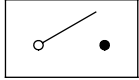
| E-pumps/functions | | CHIE |
|--|---|---|
|  | Setting via control panel: Setpoint Start/stop Max. curve Min. curve | ● ● ● ● |
| | TM00 7600 1596 Reading via control panel: Setpoint Operating indication Fault indication | ● ● ● |
|  | Setting via R100: Setpoint Start/stop Max. curve Min. curve Controlled/uncontrolled PI-controller Signal relay Operating range Stop function | ● ● ● ● ● ● ● ● ● |
| | TM00 4498 2802 Reading via R100: Setpoint Operating indication Pump status | ● ● ● |
|  | TM01 0929 2797 Connection to building management system | The pumps have inputs for BUS communication. The pumps can be controlled and monitored via these inputs from a building management system or other external control system. |
|   | TM00 4533 3593 External signals Inputs: Setpoint Start/stop Sensor Digital signals: Max. curve Min. curve External fault Flow switch | ● ● ● ● ● ● ● |
| | Outputs: Signal | ● |

Operating modes

CHIE pumps can be connected to an external sensor enabling control to be based on pressure, differential pressure, temperature, differential temperature or flow in the system in which the pumps are installed.

CHIE pumps can be set to two operating modes: Controlled or uncontrolled operation.

In **controlled** operating mode the pump sets itself to the desired setpoint of the control parameter. The example illustrated below shows a pump with pressure control.

In **uncontrolled** operating mode the pump operates according to the constant curve set.

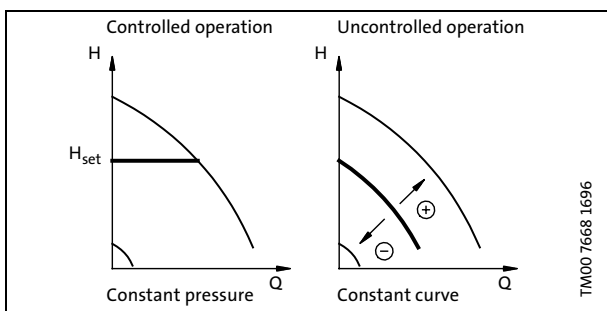

Besides normal duty (constant pressure and constant curve) CHIE features the operating modes **Stop**, **Min.** or **Max.**

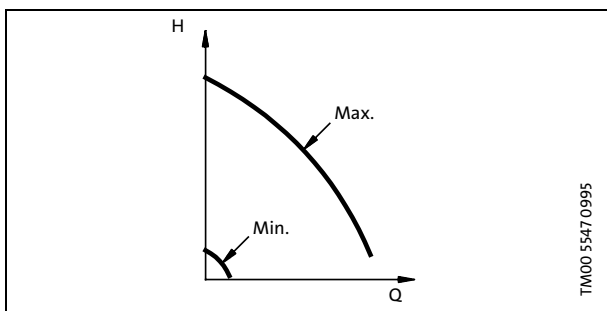

The max. curve can for instance be used in connection with the venting procedure during installation.

The min. curve can be used in periods of very low demand.

The operating modes (Stop, Normal, Min., Max.) can all be set on the control panel on the pump terminal box.

The pumps are factory-set to uncontrolled operation from factory. The setpoint value corresponds to 100% of max. pump performance.

Control panel

The control panel on the pump terminal box incorporates:

- Buttons, "+" and "-", for setpoint setting.
- Light fields, yellow (setpoint indication).
- Indicator lights, green (operation) and red (fault).

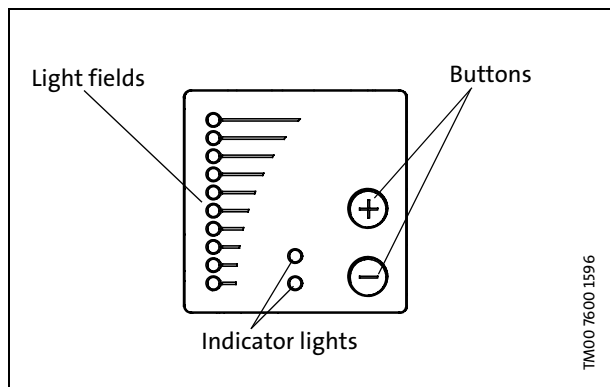

Setpoint setting

The pump setpoint is set by pressing the "+" or "-" buttons.

The light fields on the control panel indicate the setpoint set. The 10 yellow light fields indicate the setting range and are equal to the measuring range of the sensor connected. See the following two examples.

Example 1: Pump in controlled operating mode (differential pressure control):

In the illustration below the light fields 5 and 6 are on. As the sensor used has a measuring range from 0 to 8 m this indicates a setpoint of 4 m.

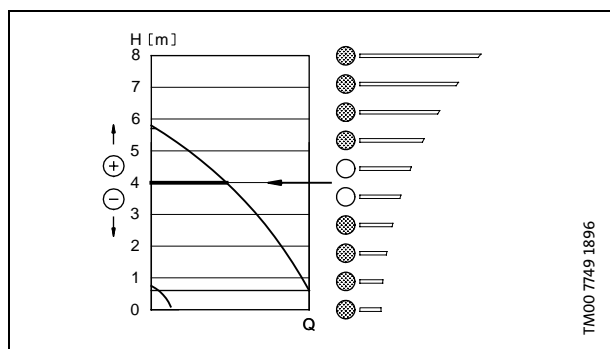

Example 2: Pump in uncontrolled operating mode:

In uncontrolled operating mode, the pump performance can be set within the range from min. to max. curves.

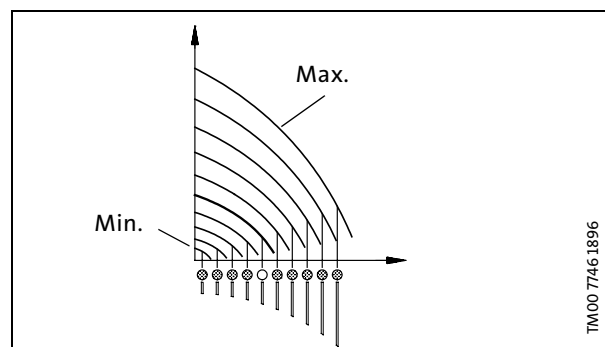

Setting to max. curve duty

Press "+" continuously to change over to the max. curve of the pump (top light field flashes).

To change back, press "-" continuously until the desired setpoint is indicated.

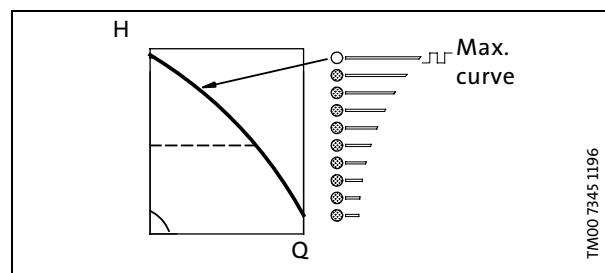

Setting to min. curve duty

Press "-" continuously to change over to the min. curve of the pump (bottom light field flashes).

To change back, press "+" continuously until the desired setpoint is indicated.

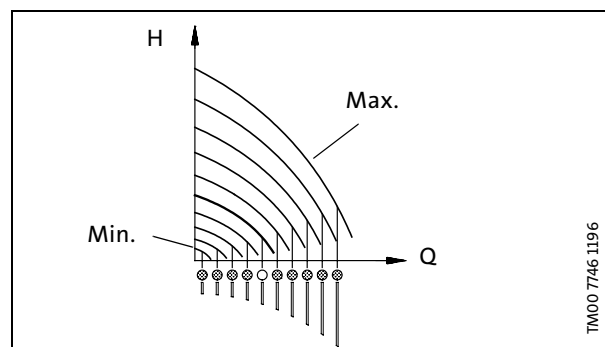

Start/stop of pump

Stop the pump by continuously pressing "-" until none of the light fields are on and the green indicator light is flashing.

Start the pump by continuously pressing "+" until the desired head is indicated.

Setting by means of R100

The pump is designed for wireless communication with the Grundfos remote control R100. Communication is effected by means of infra-red light. The transmitter and receiver unit is placed in the pump control panel.

R100 offers possibilities of both pump settings and status readings. The displays are divided into four parallel menus:

- 0. GENERAL
- 1. OPERATION
- 2. STATUS
- 3. INSTALLATION

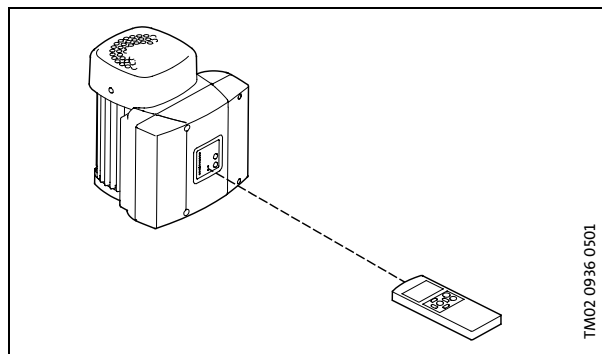

TM02 09 36 0501

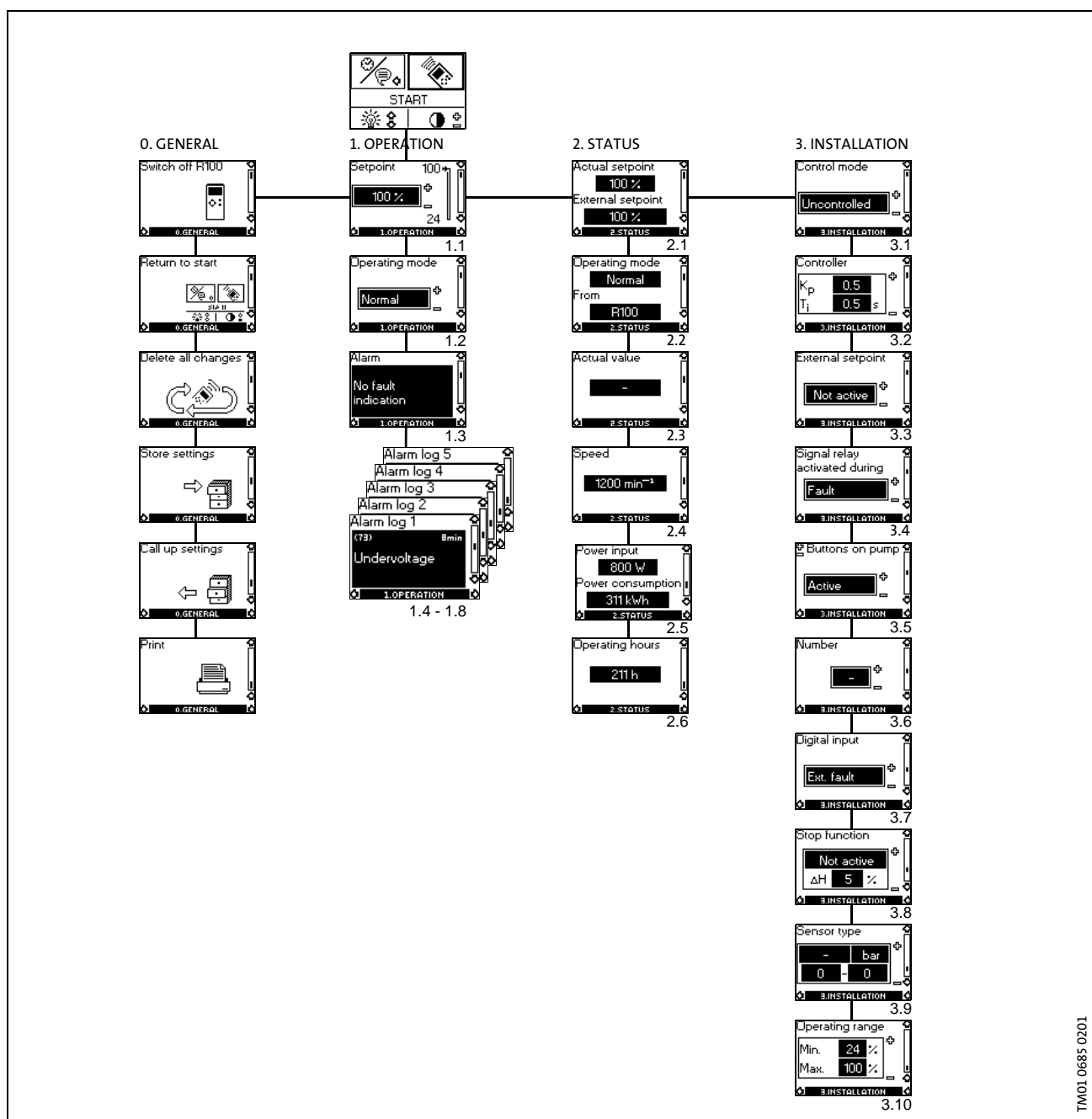

TM01 0685 0201

Menu OPERATION

The R100 remote control enables the following operating mode settings.

1.1 Setpoint

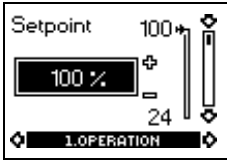

In this display, the desired setpoint can be set.

In controlled operating mode the setting range is equal to the sensor measuring range, e.g. 0 to 25 m.

In uncontrolled operating mode the setpoint is set in % of max. performance. The setting range lies between the min. and max. curves.

1.2 Operating mode

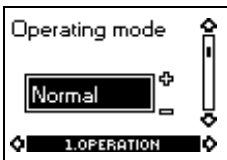

Select one of the following operating modes:

- Stop
- Min.
- **Normal (duty)**
- Max.

1.3 Fault indications

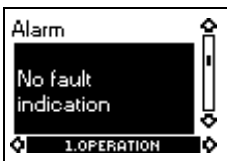

If the pump is faulty, one of the texts will appear in the display.

- Too high motor temperature
- Undervoltage
- Overvoltage
- Too many restarts (after faults)
- Overload
- Sensor signal outside signal range
- Setpoint signal outside signal range (only 4-20 mA)
- External fault
- Dry running
- Other fault.

A fault indication can be reset in this display if the cause of the fault has disappeared.

1.4-1.8 Alarm log

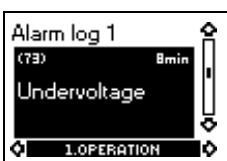

If faults have been indicated, the last five fault indications will appear in the alarm log. "Alarm log 1" shows the newest/latest fault.

The example shows the fault indication "Undervoltage", the fault code and the number of minutes the pump has been connected to the electricity supply after the fault occurred.

Menu STATUS

The displays appearing in this menu are status displays only. It is not possible to change or set values.

The tolerances are stated as a guide in % of the maximum values of the parameters.

2.1 Actual setpoint

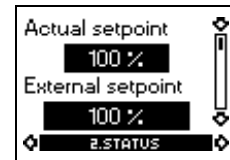

Tolerance: $\pm 2\%$

This display shows the current setpoint and the external setpoint in % of the range from the minimum value to the setpoint set. See "External setpoint signal" page 17.

2.2 Operating mode

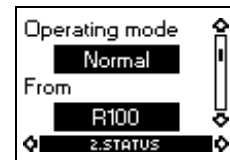

This display shows the selected operating mode:

- Stop
- Min.
- **Normal (duty),**
- Max.

It also shows where this operating mode was selected (R100, BUS or External).

2.3 Actual value

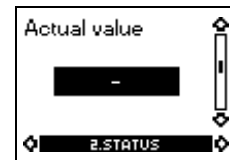

Tolerance: $\pm 3\%$

2.4 Speed



Tolerance: $\pm 5\%$

2.5 Power input

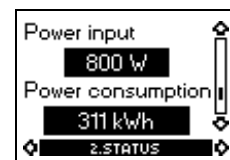

Tolerance: $\pm 10\%$

The power consumption value is accumulated from the beginning of pump operation, and it cannot be reset.

2.6 Operating hours



Tolerance: $\pm 2\%$

The operating hours are an accumulated value and cannot be reset.

Menu INSTALLATION

3.1 Control mode



Select one of the following control modes:

- Controlled
- **Uncontrolled.**

3.2 Controller

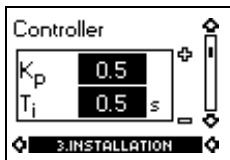

- The gain (K_p) is set within the range from 0.1 to 20.
- The integral-action time (T_i) is set within the range from 0.1 to 3600 s. If 3600 s is selected, the controller will function as a P-controller.

The gain (K_p) and intergral-action time (T_i) of the built-in PI-controller can be changed, should factory settings be inadequate.

Furthermore, it is possible to set the controller to inverse control, i.e. if the setpoint is increased, the speed will be reduced. In the case of inverse control, the gain (K_p) must be set within the range from -0.1 to -20 .

3.3 External setpoint



Select one of the following types:

- 0-10 V
- 0-20 mA
- 4-20 mA
- **Not active.**

If "Not active" is selected, the setpoint set by means of the R100 or the control panel will apply.

3.4 Signal relay



The signal relay can be set to activation by:

- **Fault** (fault indication),
- Operation (operating indication),
- Ready (ready indication).

3.5 Buttons on pump

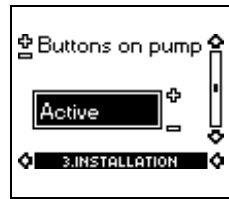

The buttons "+" and "-" on the pump can be set to:

- **Active (buttons are not locked)**
- Not active (buttons are locked).

3.6 Pump number

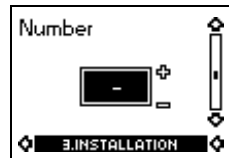

A number between 1 and 64 can be allocated to the pump. In the case of BUS communication, a number must be allocated to each pump.

3.7 Digital input

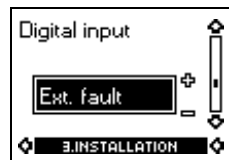

Select one of the following functions:

- Min. (min. curve),
- Max. (max. curve),
- **Ext. fault** (external fault),
- Flow switch.

The selected function is activated by closing the contact between the following terminals:

- 1 and 9 of single-phase pumps
- 1 and 3 of three-phase pumps

See "Other connections" page 20.

- **Min.:** When the input is activated, the pump is operating according to the min. curve.
- **Max.:** When the input is activated, the pump is operating according to the max. curve.
- **Ext. fault:** When the input is activated, a timer is started. If the input is activated for more than 5 seconds, the pump is stopped and a fault is indicated. If the digital input is disconnected for more than 5 seconds, the fault condition will cease and the pump can be restarted manually by resetting the fault indication.

The typical situation will be detection of missing inlet pressure or water shortage by means of a pressure switch installed on the suction side of a pump.

- **Flow switch:** When the input is activated, the pump will be stopped when a connected flow switch detects a low flow. This function can only be used if the pump is connected to a pressure sensor. When the input is activated for more than 5 seconds, the stop function incorporated in the pump will take over, see "Setting of stop function" page 16.

3.8 Stop function



The stop function can be set to:

- Active
- **Not active.**

When the stop function is active, the pump will be stopped at very low flows to avoid unnecessary power consumption. This function can only be used if the pump is connected to a pressure sensor.

Low-flow detection may occur in two ways:

1. By means of the built-in "low-flow detector" which automatically starts functioning if no flow switch is chosen/connected to the digital input. The pump will check the flow regularly by reducing the speed for a short time, thus checking the change in pressure. If there is no or a small change in pressure, the pump will detect a low flow.
2. By means of a flow switch connected to the digital input. When the input is activated for more than 5 seconds, the stop function of the pump takes over. Unlike the built-in low-flow detector, the flow switch measures the minimum flow at which the pump must stop. The pump will not check the flow regularly by reducing the speed.

When the pump detects a low flow, the speed will be increased until the stop pressure (actual setpoint + 0.5 x ΔH) is reached and the pump stops. When the pressure has fallen to the start pressure (actual setpoint - 0.5 x ΔH), the pump will restart. ΔH indicates the difference between start and stop pressures.

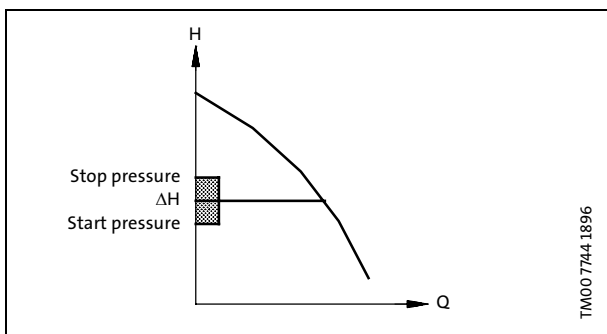

ΔH is factory-set to 10% of actual setpoint. ΔH can be set within the range from 5% to 30% of actual setpoint.

Note: A non-return valve must be fitted immediately before the pump. If the non-return valve is fitted between pump and diaphragm tank, the pressure sensor must be fitted after the non-return valve.

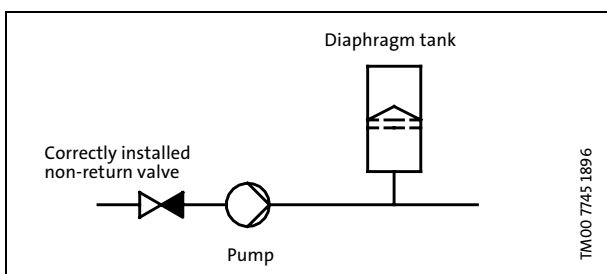

The stop function requires a diaphragm tank of a certain size. The tank must be installed immediately after the pump and the precharge pressure must be 0.7 x actual setpoint.

Recommended diaphragm tank size when no flow switch is connected.

| Nominal flow of pump [m ³ /h] | Diaphragm tank size [litres] |
|--|------------------------------|
| 0-6 | 8 |
| 7-14 | 18 |

If a diaphragm tank of the above size is installed in the system, the factory setting of ΔH is the correct setting. If the tank installed is too small, the pump will start and stop too often. This can be remedied by increasing ΔH .

3.9 Sensor type

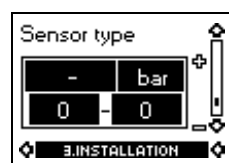

Select the following:

- Sensor output signal (0-10 V, 0-20 mA or 4-20 mA),
- sensor measuring unit (bar, mbar, m, kPa, psi, ft, m³/h, m³/s, l/s, gpm, °C, °F or %) and
- sensor measuring range.

The setting of the sensor is only to be made in the case of controlled operation.

3.10 Operating range

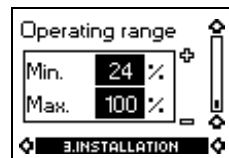

If the operating range must be reduced set the min. and max. curves in % of maximum performance.

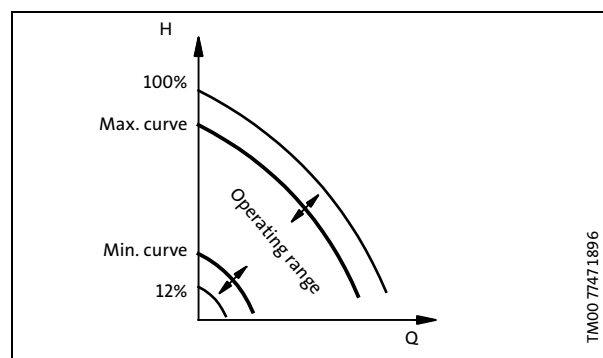

- The max. curve can be adjusted within the range from maximum performance (100%) to min. curve.
- The min. curve can be adjusted within the range from max. curve to 12% of maximum performance. The min. curve has been factory-set to 24% of maximum performance.
- The operating range **must** lie between the min. and max. curves.

External forced-control signals

The pump has inputs for external signals for the forced-control functions:

- Start/stop of pump.
- Digital function.

Functional diagram: Start/stop:

| Start/stop input (terminals 2 and 3) | | |
|--------------------------------------|--|-------------|
| | | Normal duty |
| | | Stop |

By means of the R100, one of the following functions can be selected for the digital input:

- Min. curve,
- Max. curve,
- External fault,
- Flow switch.

Functional diagram: Input for digital function:

| Digital function input (terminals 1 and 9) | | |
|--|--|----------------|
| | | Normal duty |
| | | Min. curve |
| | | Max. curve |
| | | External fault |
| | | Flow switch |

External setpoint signal

Connecting an analog signal transmitter to the input for the setpoint signal (terminal 4), enables remote setting of the setpoint. The external signal (0-10 V, 0-20 mA, 4-20 mA) **must** be selected via the R100.

If uncontrolled operation is selected by means of the R100, the pump can be controlled by any controller.

In **controlled** operating mode, the setpoint can be set externally within the range from the lower value of the sensor measuring range to the setpoint set on the pump or by means of the R100.

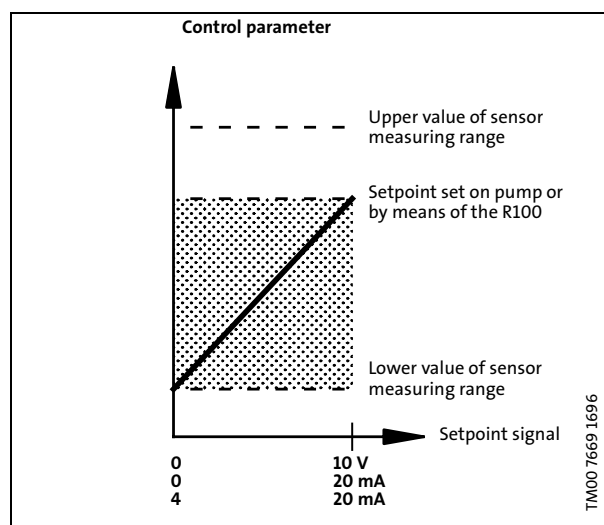

Example: If the lower pressure-sensor value is 0 bar, the setpoint set is 20 bar and the external setpoint is 80%, the setpoint will be as follows:

$$\begin{aligned}
 H_{\text{actual}} &= (H_{\text{set}} - H_{\text{lower}}) \times \% \text{external setpoint} + H_{\text{lower}} \\
 &= (20 - 0) \times 80\% + 0 \\
 &= 16 \text{ bar}
 \end{aligned}$$

In **uncontrolled** operating mode, the setpoint can be set externally within the range from the min. curve to the setpoint set on the pump or by means of the R100.

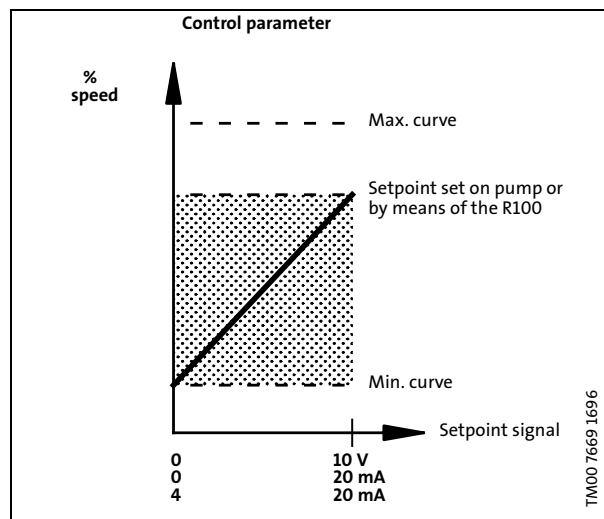

Indicator lights and signal relay

The operating condition of the pump is indicated by the green and red indicator lights on the pump control panel. The pump incorporates an output for a potential-free signal via an internal relay.

The signal relay of CHIE can be set to fault indication, operating indication or ready indication by means of R100.

This setting cannot be changed. The functions of the two indicator lights on the control panel and the signal relay are as shown in the following table:

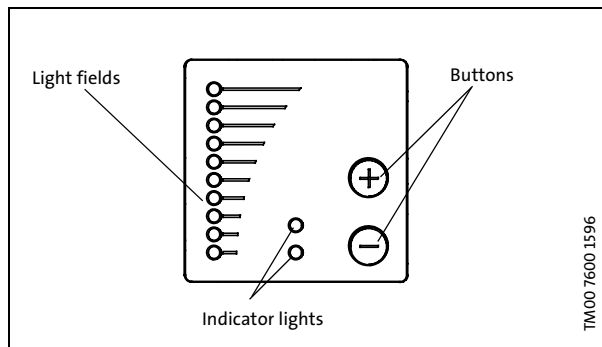

| Indicator lights | | Signal relay activated during: | | | Description |
|------------------|-------------------|--------------------------------|-----------|-------|--|
| Fault (red) | Operation (green) | Fault | Operation | Ready | |
| Off | Off | | | | The electricity supply has been switched off. |
| Off | Permanently on | | | | The pump is operating. |
| Off | Flashing | | | | The pump has been set to stop. |
| Permanently on | Off | | | | The pump has stopped because of a fault. Restarting will be attempted (it may be necessary to restart the pump by resetting the fault indication). In case of the fault causes "dry running" and "external fault", the pump must be restarted manually by resetting the fault indication. |
| Permanently on | Permanently on | | | | The pump is operating, but it has been stopped because of a fault. If the cause is "sensor signal outside signal range", the pump will continue operating according to the max. curve and the fault indication cannot be reset until the signal is inside the signal range. If the cause is "setpoint signal outside signal range", the pump will continue operating according to the min. curve and the fault indication cannot be reset until the signal is inside the signal range. |
| Permanently on | Flashing | | | | The pump has been set to stop, but it has been stopped because of a fault. |

A fault indication can be reset in one of the following ways:

- By briefly pressing the buttons "+" or "-" on the pump. This will not change the setting of the pump. A fault indication cannot be reset by means of "+" or "-" if the buttons have been locked.
- By briefly switching off the electricity supply to the pump.
- By means of the R100. When the R100 communicates with the pump, the red indicator light will flash rapidly.

Introduction

To ensure cooling of motor and electronics, please observe these points:

- place the pump in such a way that sufficient cooling is ensured.
- The temperature of the cooling air must not exceed 40°C.
- Motor cooling fins, holes in fan cover and fan blades must be kept clean.

When installed outdoors, the motor must be provided with a suitable cover to avoid condensation on the electronic components.

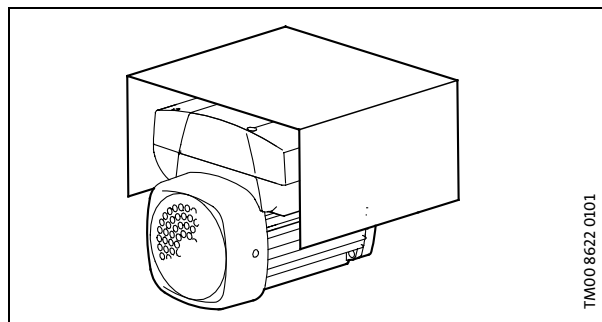

Electrical connection

The electrical connection and protection should be carried out in accordance with local regulations.

- The pump must be connected to an external mains switch.
- The pump **must** be correctly earthed.
- The pump requires no external motor protection. The motor incorporates thermal protection against slow overloading and seizure (IEC 34-11: TP 211).
- When the pump is switched on via the mains, the pump will start after approx. 5 seconds.

Note: The number of starts and stops **must** not exceed four times per hour.

The pump mains connection must be made as shown in the wiring diagram below.

Wiring diagram

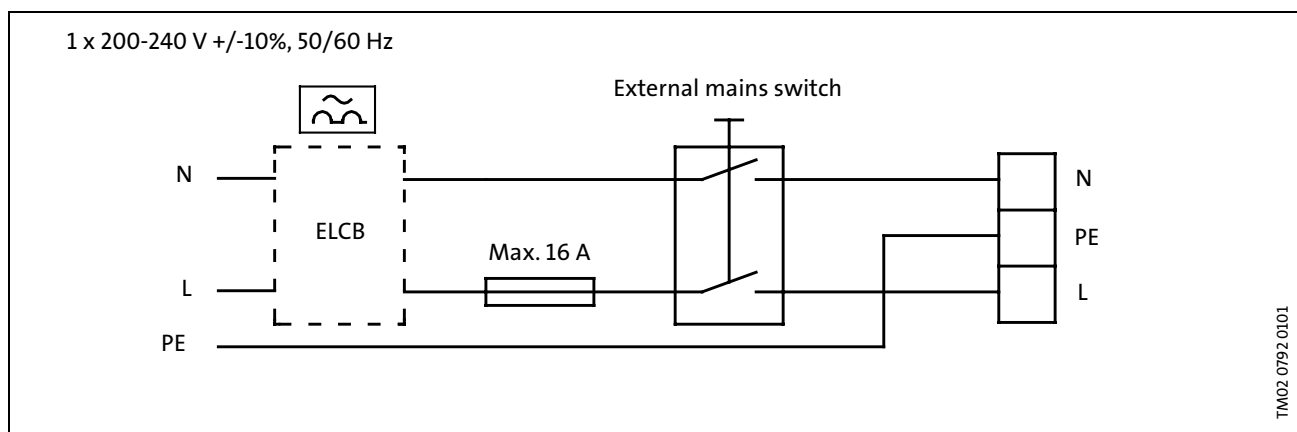

Additional protection

If the pump is connected to an electric installation where an earth leakage circuit breaker (ELCB) is used as an additional protection the earth leakage circuit breaker must be marked with the following symbol.



The earth leakage circuit breaker **must** trip out when earth fault currents with DC content (pulsating DC) occur.

If the electricity supply to the pump is disconnected, the pump setting will be stored.

Other connections

External potential-free contacts for start/stop and digital function, external setpoint signal and fault signal can be connected, see wiring diagram below.

Wiring diagram

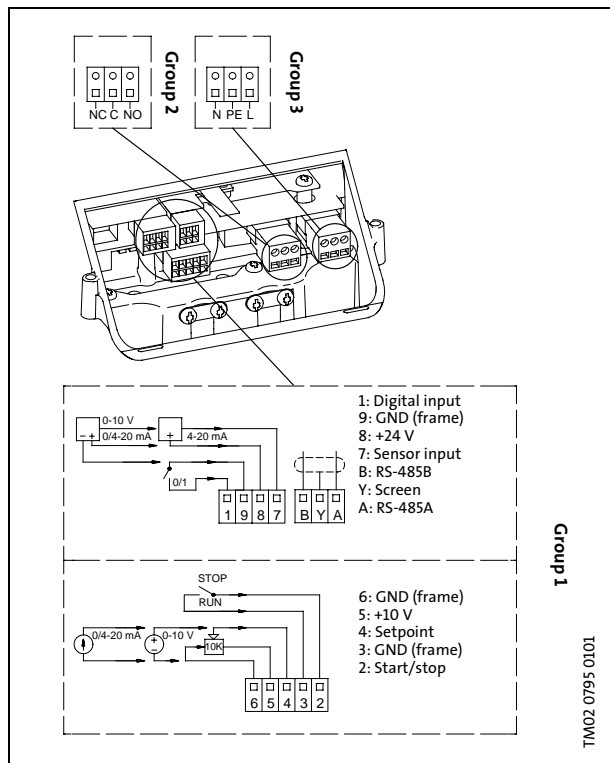

The wires can be connected to the following connection groups:

Group 1: Inputs (external start/stop, digital function, setpoint and sensor signals, terminals 1-9 and bus connection, A, Y, B).

All inputs are separated from the live wires by reinforced insulation.

Group 2: Output (fault signal relay).

The output terminals C, NO and NC are electrically separated from other circuits. Therefore, the supply voltage or a safety extra-low voltage can be connected to the output as desired.

Group 3: Mains supply.

Note:

- As a precaution, the wires must be separated from each other by reinforced insulation in their entire lengths.
- Maintain the connection across terminals 2 and 3, if no external on/off switch is connected.

Cables

Use screened cables (min. 0.5 mm²) for external on/off switch, digital input, sensor and setpoint signals. The cable screens should be connected to frame at both ends.

The cable screen must have good frame connection. The connection point must be as close as possible to the terminals.

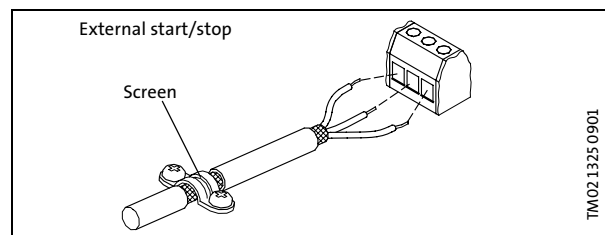

Use a screened 2-core cable for the BUS connection. Connect the screen to terminal Y at both ends.

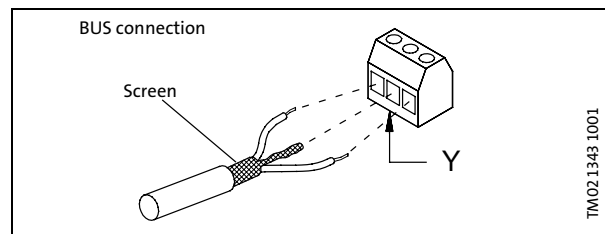

External force control

Functional diagram: Start/stop

| Start/stop input (terminals 2 and 3) | | |
|--------------------------------------|--|-------------|
| | | Normal duty |
| | | Stop |

Functional diagram: Digital function

| Digital function input terminals 1 and 9 | | |
|--|--|-------------|
| | | Normal duty |
| | | Min. curve |
| | | Max. curve |

Select the function for digital input by means of the Grundfos R100. CHIE is supplied with external fault as factory setting.

Performance curves

The curve charts on the following pages show QH-curves and QP1-curves for 100%, 90%, 80%, 70%, 60%, 50% and 25% speed.

In the QH-chart the 100%-curve corresponds to the curve for a pump fitted with a standard fixed speed motor. In principle pumps with MGE motors have an infinite number of performance curves each representing a specific speed.

The P₁ chart states pump input power depending on the flow and the chosen speed.

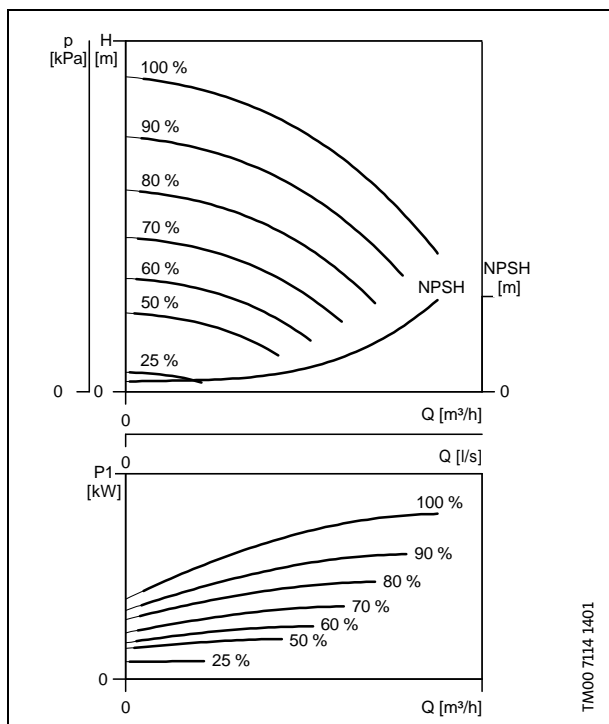

Curve conditions

The guidelines below apply to the curves shown on the following pages:

1. Tolerances to ISO 9906, Annex A, if indicated.
2. Measurements were made with airless water at a temperature of 20°C.
3. The curves apply to a kinematic viscosity of $\nu = 1 \text{ mm}^2/\text{s}$ (1 cSt).
4. The **bold** curves indicate the **recommended** performance range. The thin curves are only a **guide**.
5. Due to the risk of overheating, the pumps should not be used at a flow below the minimum flow rate.

The curve below shows the minimum flow rate as a percentage of the rated flow rate in relation to the liquid temperature.

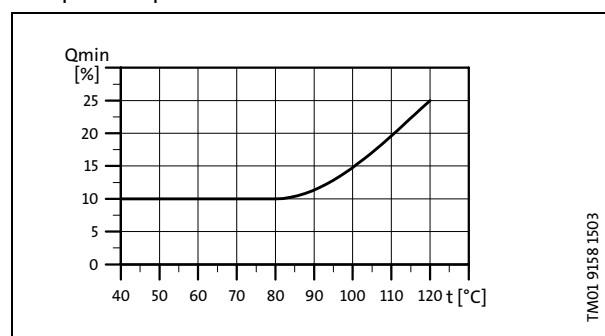

Performance curves

CHIE

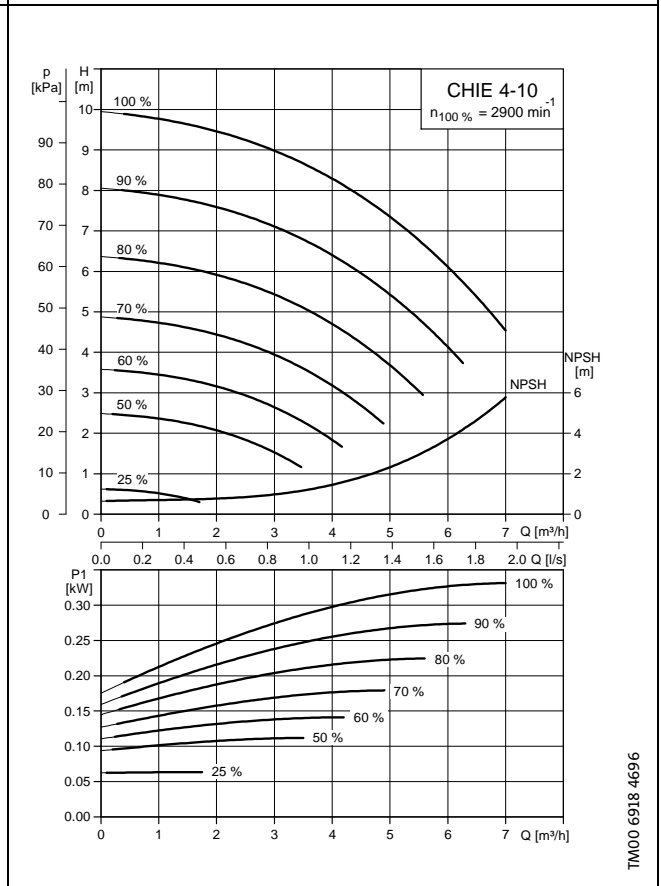
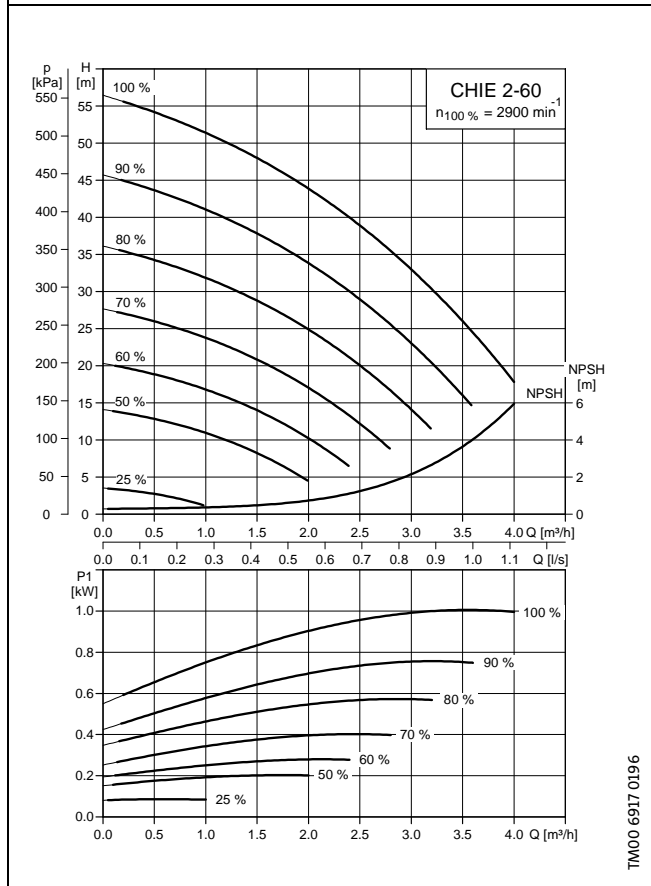
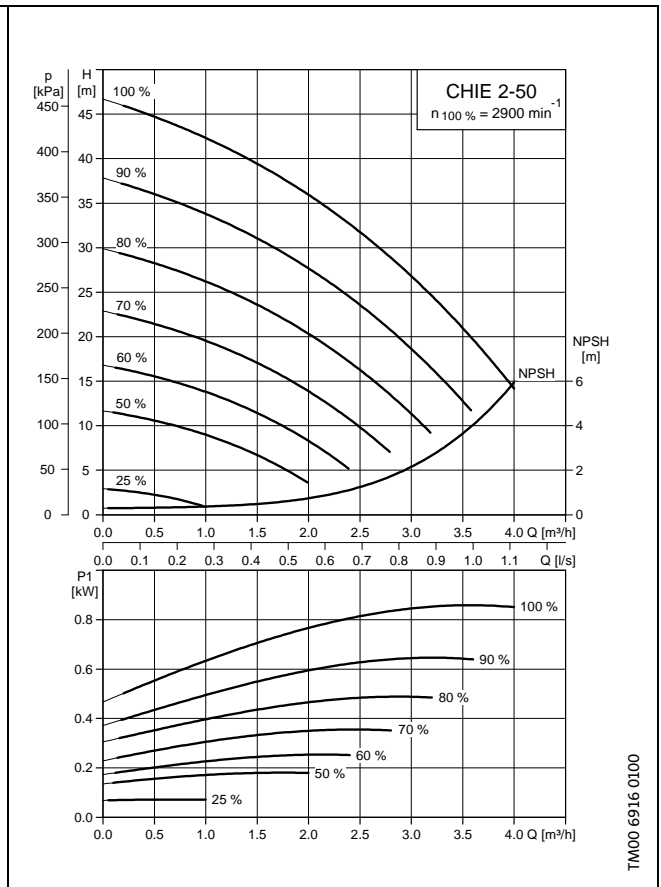
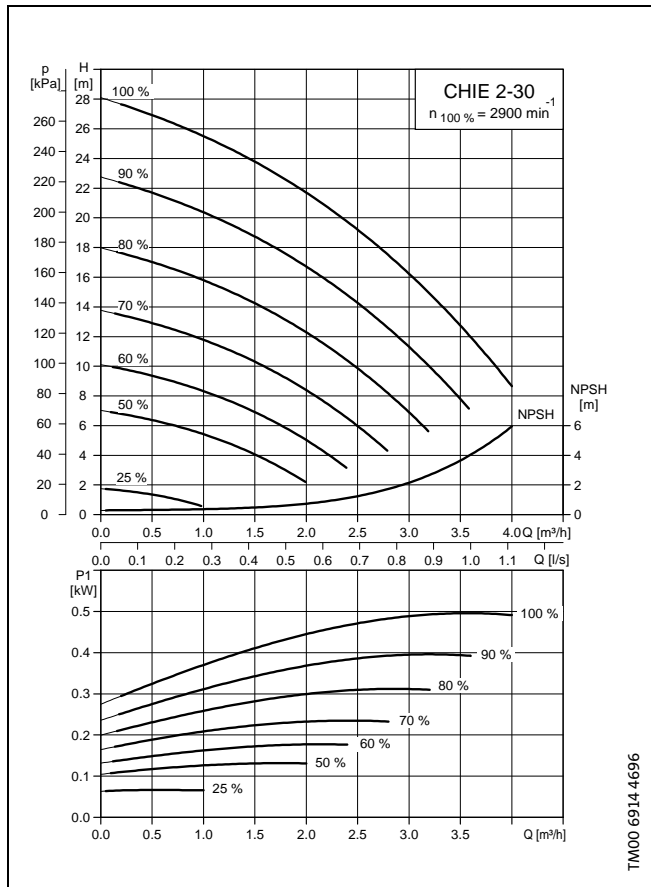

Performance curves

CHIE

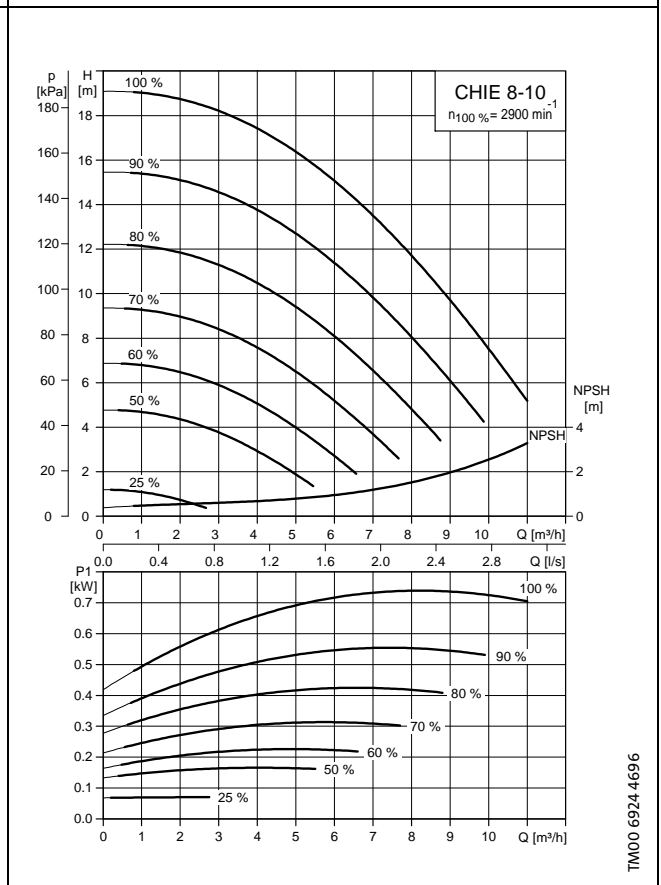
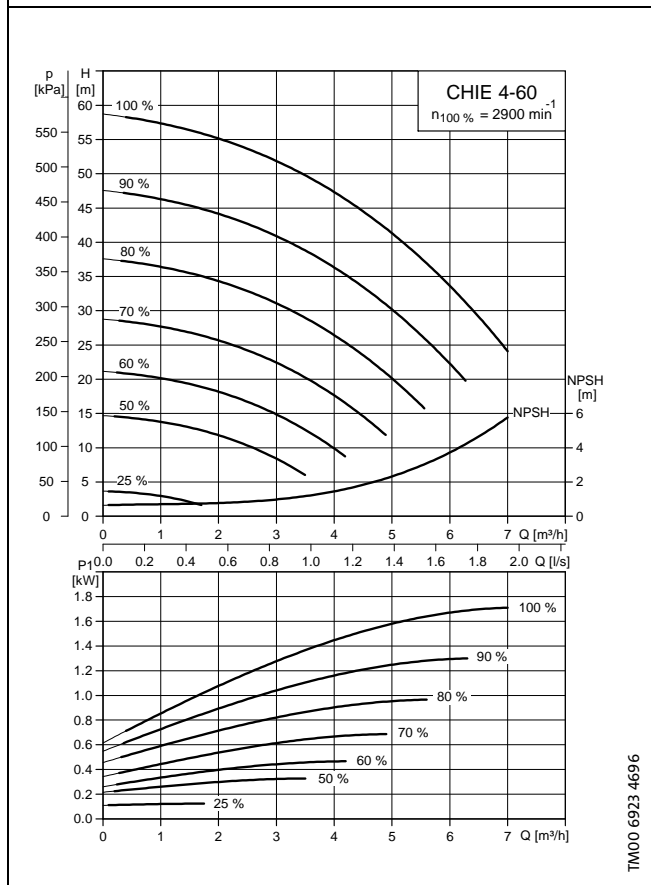
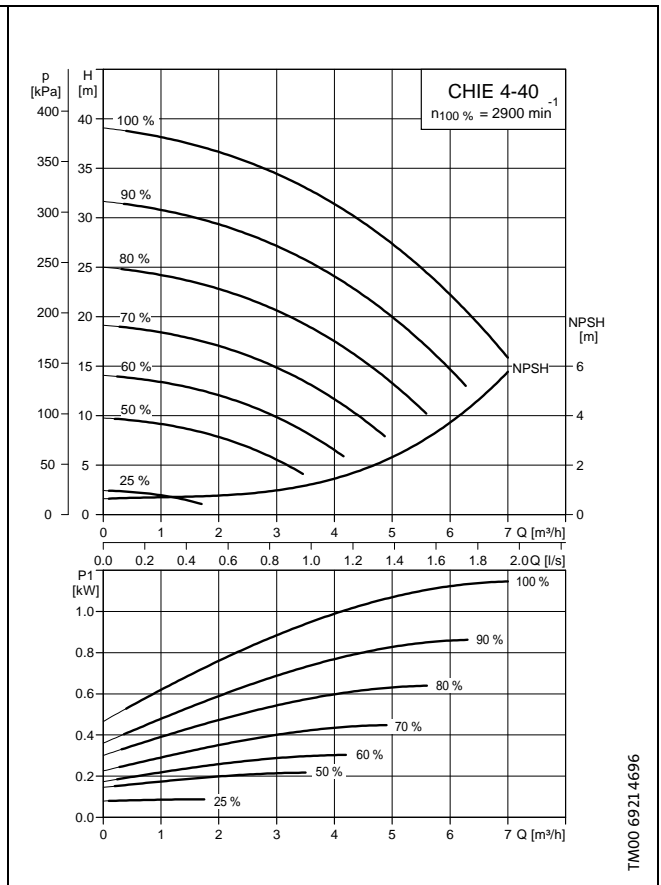
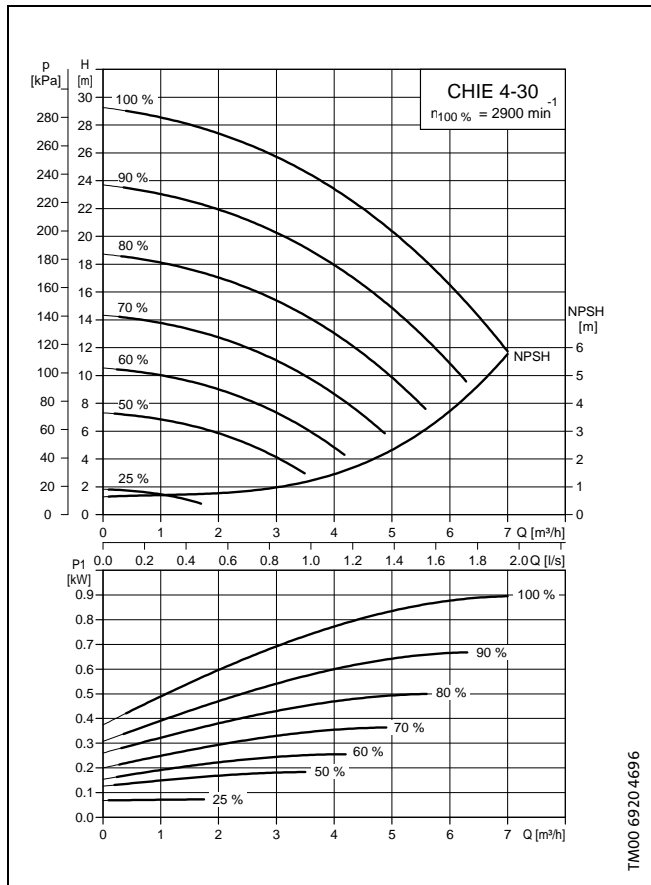

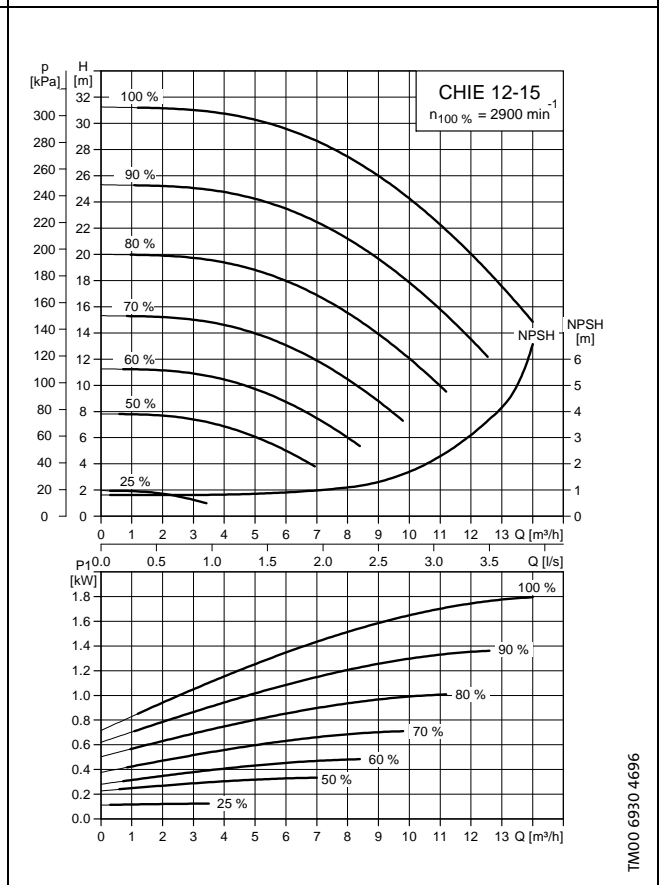
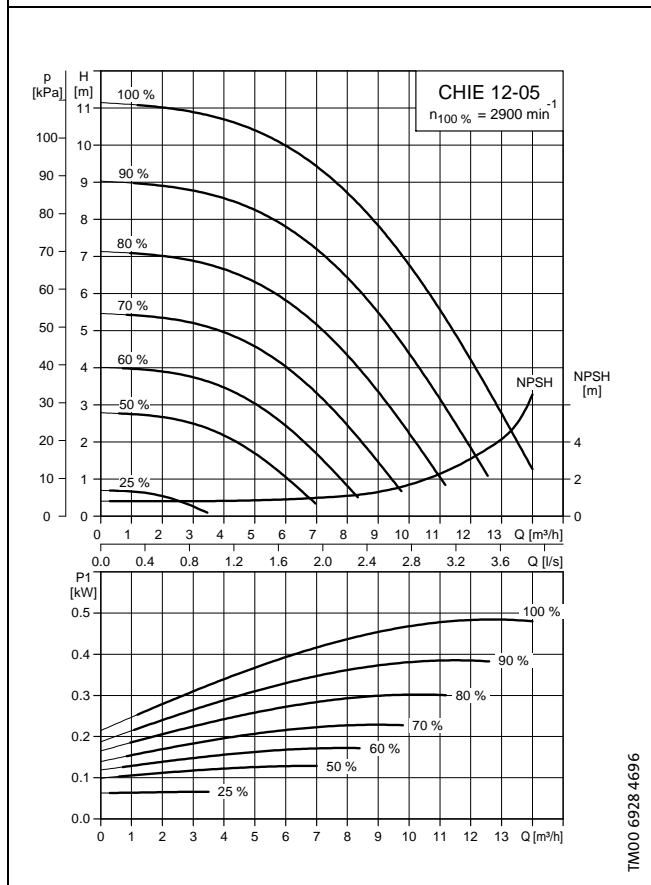
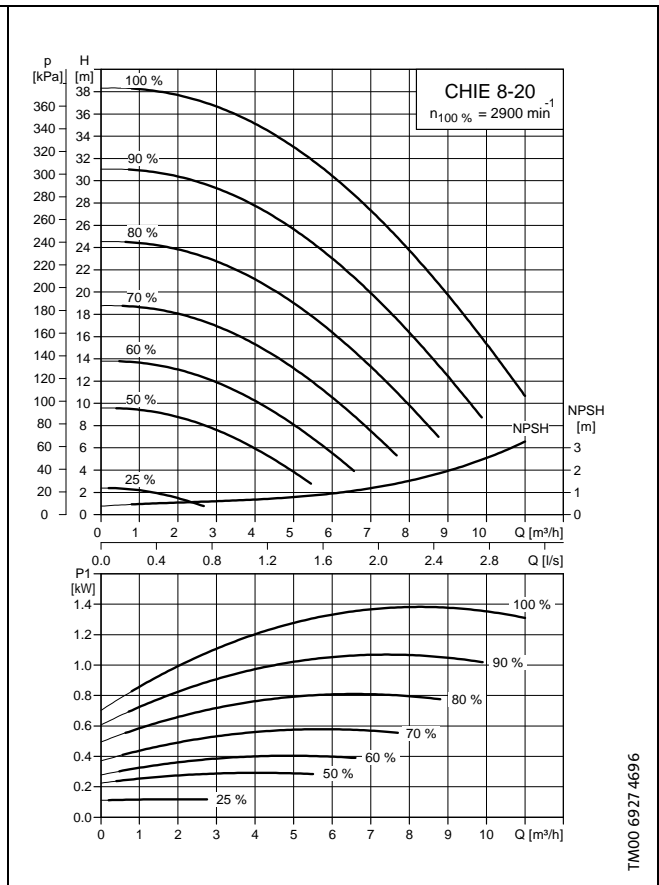
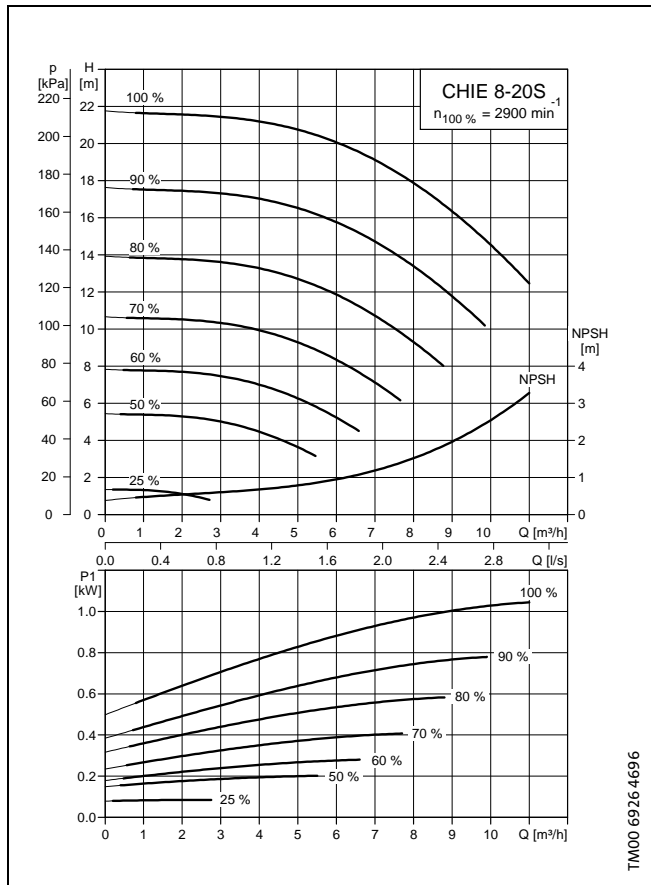

Performance curves

CHIE

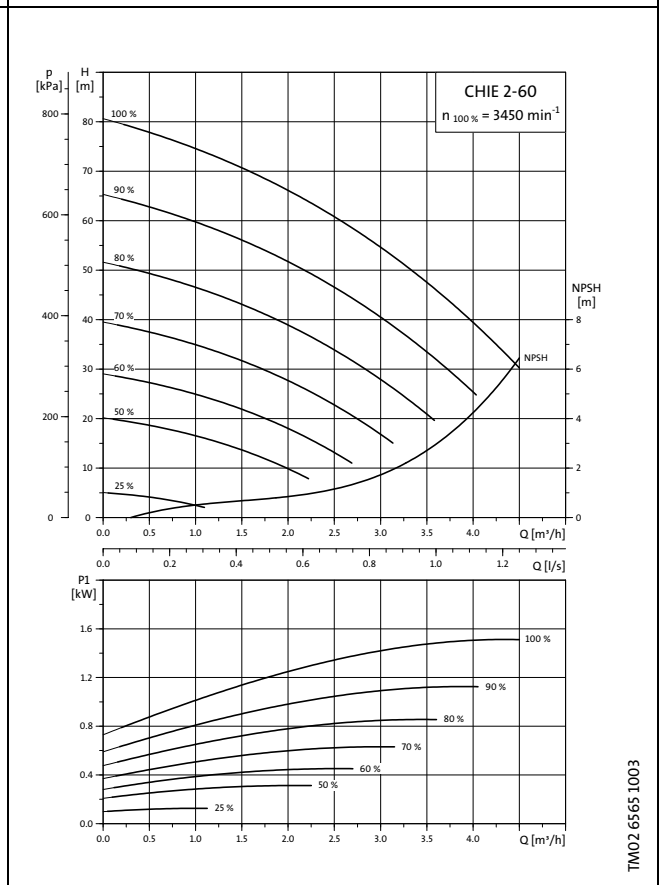
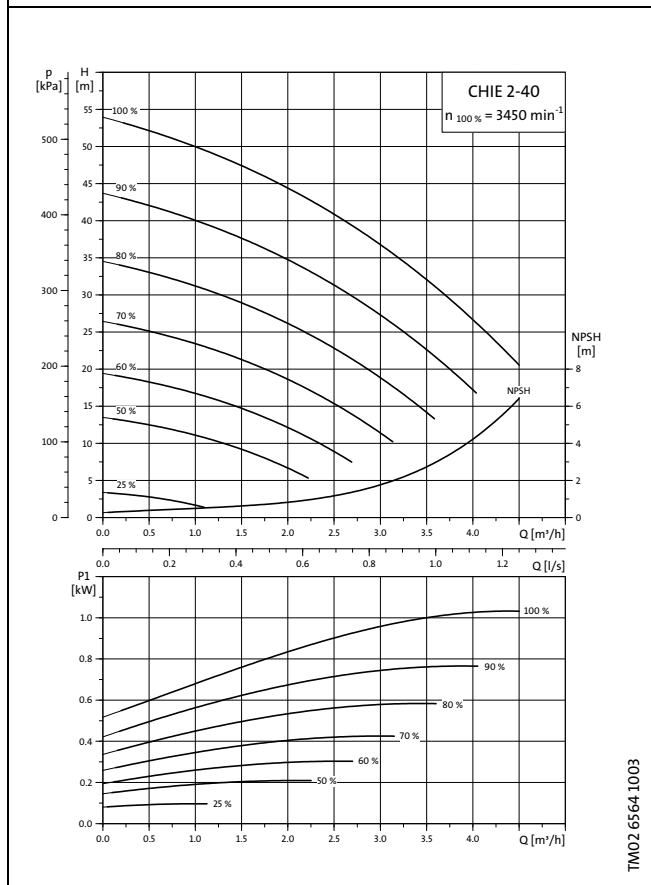
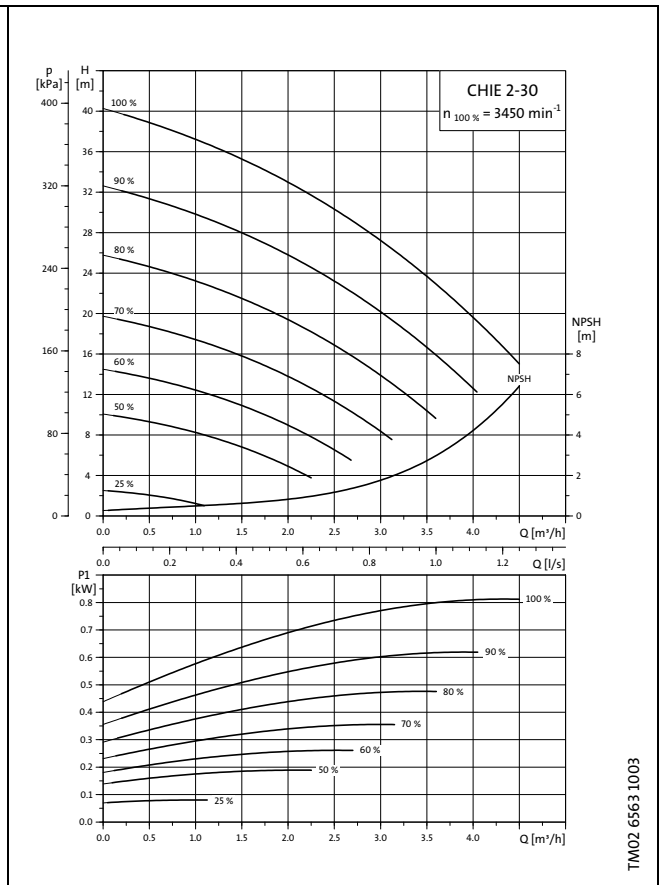
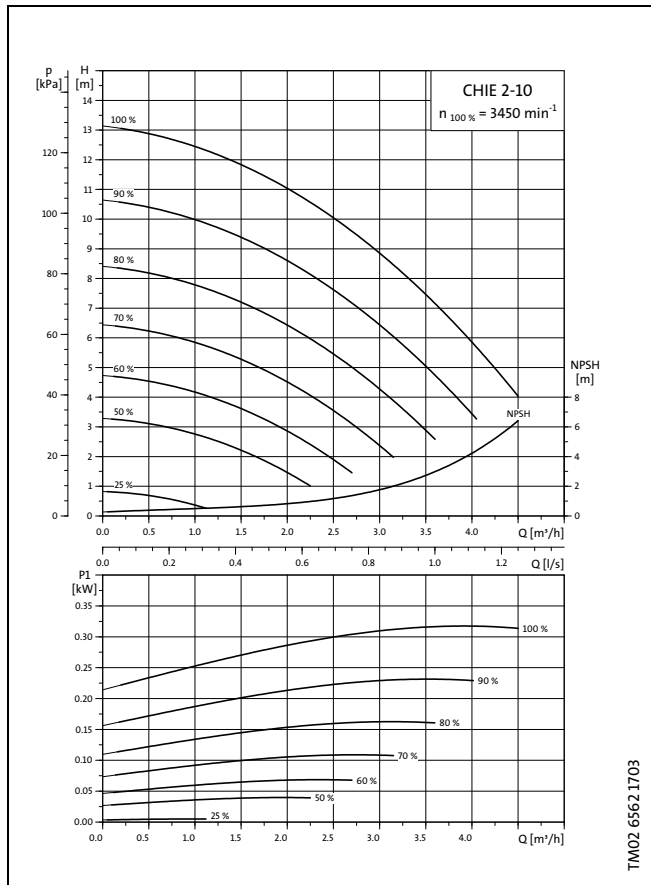

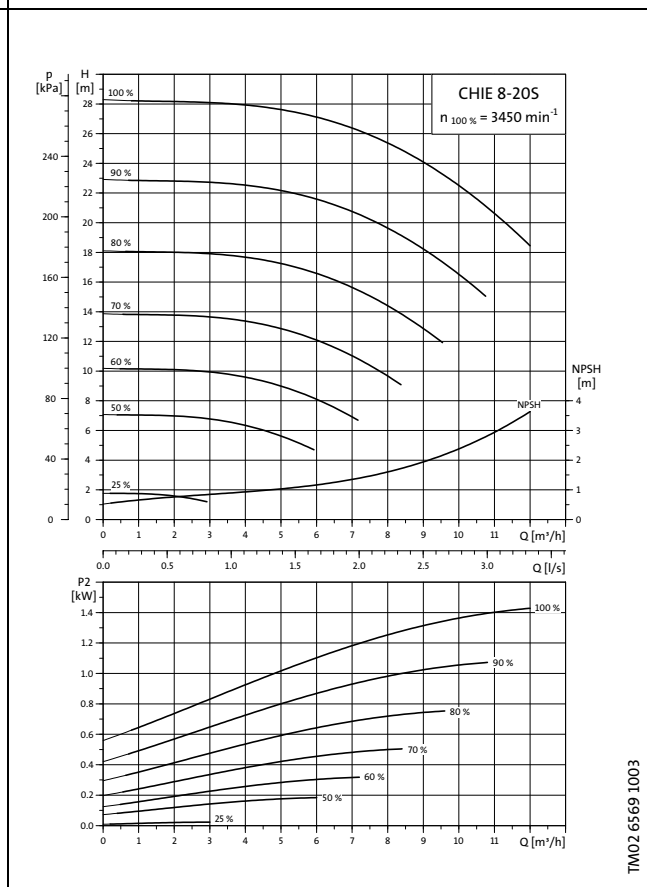
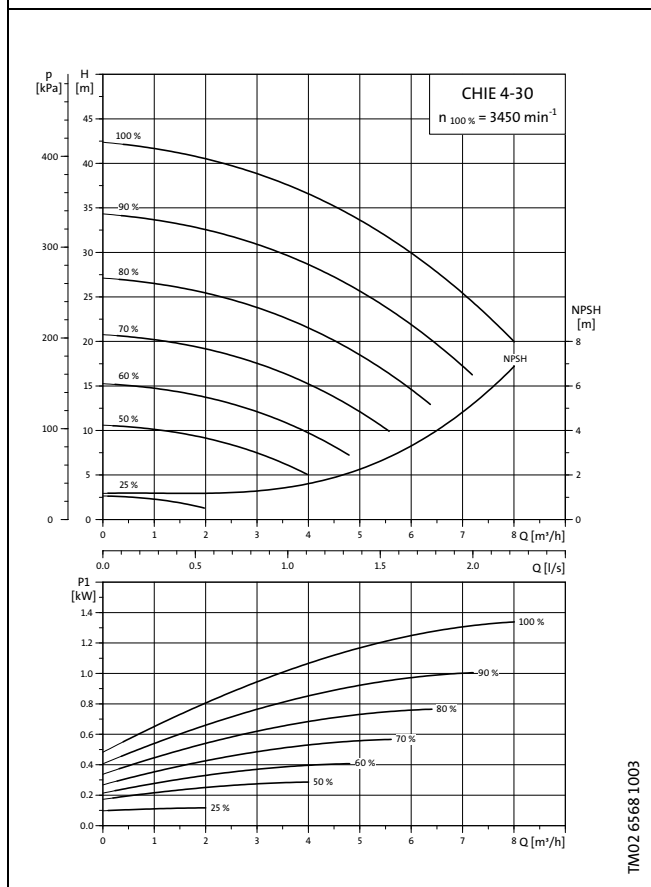
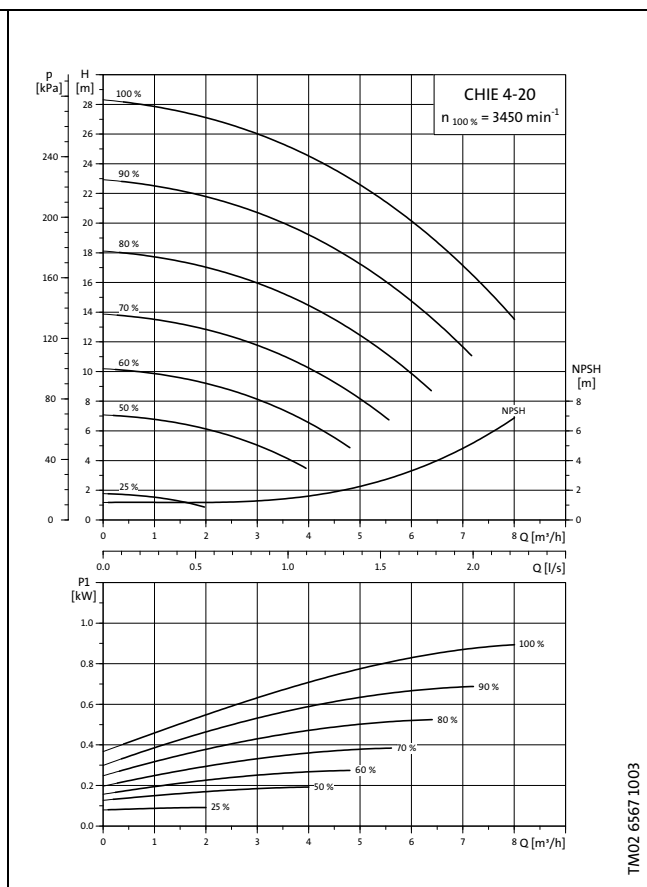
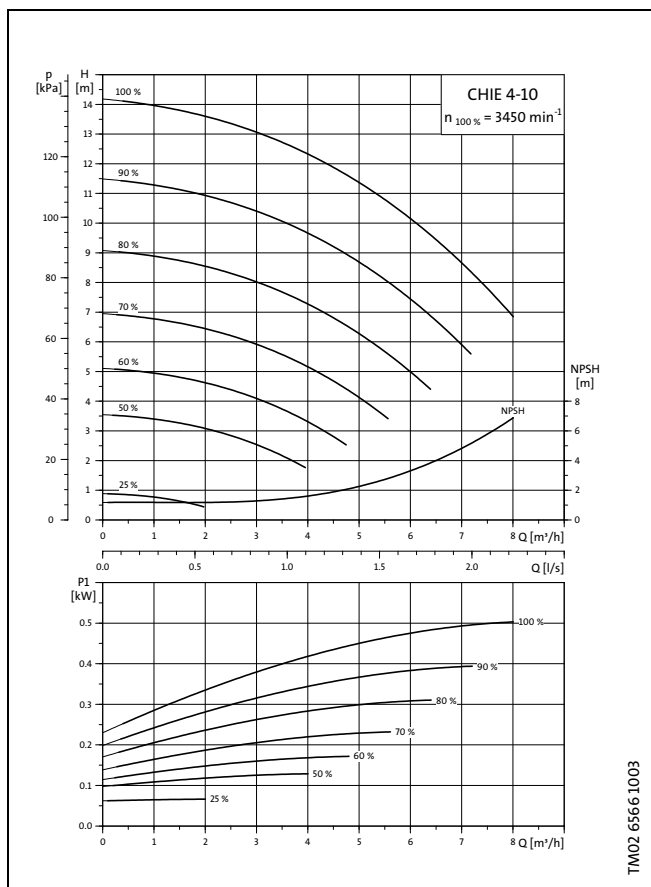

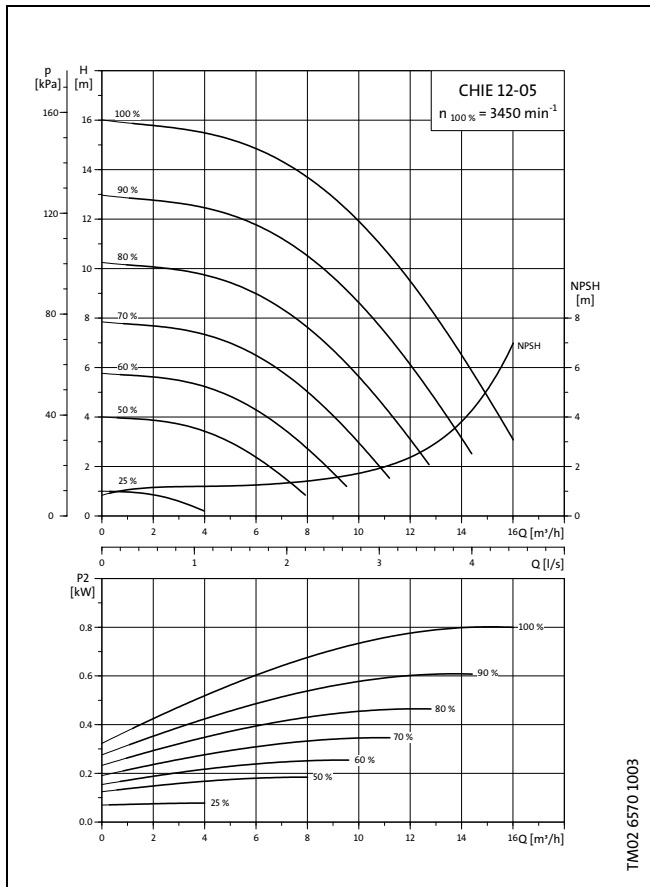

Dimensional drawing

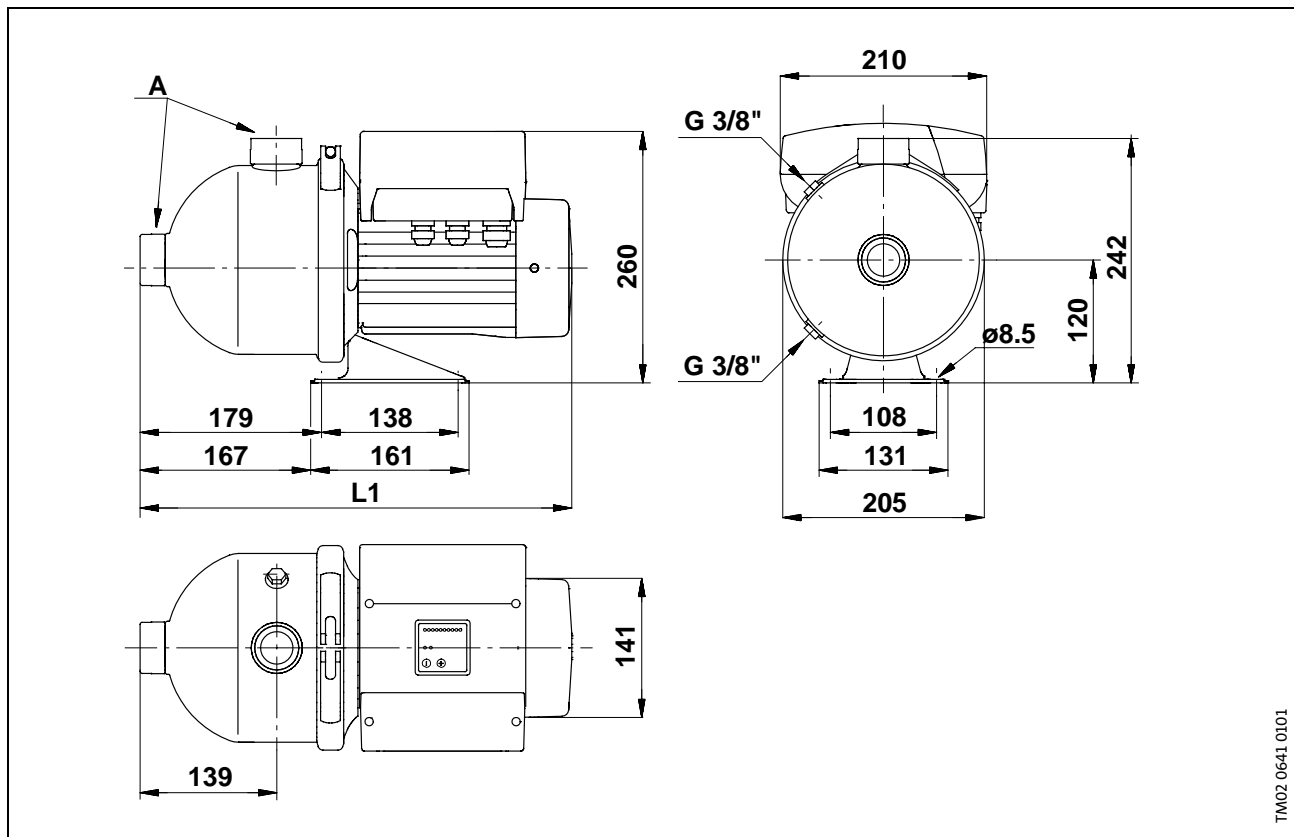

TM02 0641 0101

Dimensions and weights, 2900 min⁻¹

| Pump type | Dimensions [mm] | | Weights [kg] | | Shipping vol. [m ³] |
|------------|-----------------|-------|--------------|-------|---------------------------------|
| | L1 | A | Net | Gross | |
| CHIE 2-30 | 397 | Rp 1 | 12.0 | 14.7 | 0.054 |
| CHIE 2-50 | 397 | Rp 1 | 13.0 | 15.7 | 0.054 |
| CHIE 2-60 | 437 | Rp 1 | 14.8 | 17.5 | 0.054 |
| CHIE 4-10 | 397 | Rp 1½ | 11.5 | 14.2 | 0.054 |
| CHIE 4-30 | 397 | RP 1½ | 12.5 | 15.2 | 0.054 |
| CHIE 4-40 | 437 | Rp 1½ | 14.3 | 17.0 | 0.054 |
| CHIE 4-60 | 437 | Rp 1½ | 16.2 | 18.9 | 0.054 |
| CHIE 8-10 | 397 | Rp 1½ | 13.0 | 15.7 | 0.054 |
| CHIE 8-20S | 437 | Rp 1½ | 14.1 | 16.7 | 0.054 |
| CHIE 8-20 | 437 | RP 1½ | 16.0 | 18.6 | 0.054 |
| CHIE 12-5 | 397 | Rp 1½ | 12.0 | 14.7 | 0.054 |
| CHIE 12-15 | 437 | Rp 1½ | 15.6 | 18.3 | 0.054 |

Dimensions and weights, 3450 min⁻¹

| Pump type | Dimensions [mm] | | Weights [kg] | | Shipping vol. [m ³] |
|------------|-----------------|--------|--------------|-------|---------------------------------|
| | L1 | A | Net | Gross | |
| CHIE 2-10 | 397 | NPT 1 | 11.5 | 14.2 | 0.054 |
| CHIE 2-30 | 397 | NPT 1 | 12.5 | 15.2 | 0.054 |
| CHIE 2-40 | 437 | NPT 1 | 13.9 | 16.2 | 0.054 |
| CHIE 2-60 | 437 | NPT 1 | 16.4 | 19.1 | 0.054 |
| CHIE 4-10 | 397 | NPT 1½ | 11.5 | 14.2 | 0.054 |
| CHIE 4-20 | 437 | NPT 1½ | 13.4 | 16.1 | 0.054 |
| CHIE 4-30 | 437 | NPT 1½ | 15.2 | 17.9 | 0.054 |
| CHIE 8-20S | 437 | NPT 1½ | 15.7 | 18.3 | 0.054 |
| CHIE 12-05 | 397 | NPT 1½ | 12.7 | 15.4 | 0.054 |

Electrical data

| | |
|--------------------------------------|---|
| Electricity supply | 1 x 200-240 V -10%/+10%, 50/60 Hz, PE. |
| External start/stop input | External potential-free contact. Maximum contact load: Voltage 5 VDC, current < 5 mA. Screened cable ★. |
| Digital input | External potential-free contact. Maximum contact load: Voltage 5 VDC, current < 5 mA. Screened cable ★. |
| Setpoint signals | <ul style="list-style-type: none"> • Potentiometer 0-10 VDC, 10 kΩ (via internal voltage supply). Screened cable ★. Maximum cable length: 100 m. • Voltage signal 0-10 VDC, $R_i > 50 \text{ k}\Omega$. Tolerance: -3%/+0% at maximum voltage signal. Screened cable ★. Maximum cable length: 500 m. • Current signal DC 0-20 mA/4-20 mA, $R_i = 175 \Omega$. Tolerance: -3%/+0% at maximum current signal. Screened cable ★. Maximum cable length: 500 m. |
| Electricity supply to sensors | The sensors are supplied with electricity via the motor terminal box. <ul style="list-style-type: none"> • 24 VDC -10%/+10% Maximum load: 40 mA. |
| Sensor signals | <ul style="list-style-type: none"> • Voltage signal 0-10 VDC, $R_i > 50 \text{ k}\Omega$. Tolerance: -3%/+0% at maximum voltage signal. Screened cable ★. Maximum cable length: 500 m. • Current signal DC 0-20 mA/4-20 mA, $R_i = 175 \Omega$. Tolerance: -3%/+0% at maximum current signal. Screened cable ★. Maximum cable length: 500 m. |
| Signal output | Potential-free changeover contact. Maximum contact load: 250 VAC, 2 A. Minimum contact load: 5 VDC, 1 mA. Screened cable: 0.5-2.5 mm ² . Maximum cable length: 500 m. |
| Bus input | Grundfos BUS protocol, GENIbus protocol, RS-485. 0.5-1.5 mm ² screened 2-core cable. Maximum cable length: 500 m. |
| EMC | EN 61 800-3 Residential areas - unlimited distribution, corresponding to CISPR 11, Class B, Group 1. |
| Enclosure class | Standard: IP 55 (IEC 34-5). |
| Insulation class | F (IEC 85). |
| Ambient temperature | During operation: -20°C to +40°C. During storage/transport: -40°C to +60°C. |
| Relative air humidity | Maximum 95%. |

★Cross section: min. 0.5 mm² and max. 1.5 mm².

Sensors

| Designation | Type | Supplier | Measuring range | Product number |
|--|--------------------------------|----------------------|------------------------------------|----------------|
| Pressure sensor • Connection: G ½ A (DIN 16288 - B6kt) • Electrical connection: plug (DIN 43650) | MBS 3000 | Danfoss | 0 - 2.5 bar | 96 47 81 88 |
| | | | 0 - 4 bar | 91 07 20 75 |
| | | | 0 - 6 bar | 91 07 20 76 |
| | | | 0 - 10 bar | 91 07 20 77 |
| | | | 0 - 16 bar | 91 07 20 78 |
| | | | 0 - 25 bar | 91 07 20 79 |
| Flowmeter | MAGFLO MAG 3100/5000 | Danfoss | 1 - 5 m ³ (DN 25) | ID8285 |
| Flowmeter | MAGFLO MAG 3100/5000 | Danfoss | 3 - 10 m ³ (DN 40) | ID8286 |
| Flowmeter | MAGFLO MAG 3100/5000 | Danfoss | 6 - 30 m ³ (DN 65) | ID8287 |
| Flowmeter | MAGFLO MAG 3100/5000 | Danfoss | 20 - 75 m ³ (DN 100) | ID8288 |
| Temperature sensor | TTA (0) 25 | Carlo Gavazzi | 0°C to +25°C | 96 43 25 91 |
| Temperature sensor | TTA (-25) 25 | Carlo Gavazzi | -25°C to +25°C | 96 43 01 94 |
| Temperature sensor | TTA (50) 100 | Carlo Gavazzi | 50°C to 100°C | 96 43 25 92 |
| Temperature sensor | TTA (0) 150 | Carlo Gavazzi | 0°C to 150°C | 96 43 01 95 |
| Accessory for temperature sensor. All with ½ RG connection. | Protecting tube ø9 x 50 mm | Carlo Gavazzi | | 96 43 02 01 |
| | Protecting tube ø9 x 100 mm | Carlo Gavazzi | | 96 43 02 02 |
| | Cutting ring bush | Carlo Gavazzi | | 96 43 02 03 |
| Temperature sensor, ambient temperature | WR 52 | tmg (DK: Plesner) | -50°C to +50°C | ID8295 |
| Differential temperature sensor | ETSD | Honsberg | 0°C to 20°C | 96 40 93 62 |
| Differential temperature sensor | ETSD | Honsberg | 0°C to 50°C | 96 40 93 63 |

Note: All sensors have 4-20 mA signal output.

| Danfoss pressure sensor kit | | |
|---|----------------|----------------|
| Kit consisting of.. | Pressure range | Product number |
| <ul style="list-style-type: none"> Danfoss pressure sensor type MBS 3000, with 2 m screened cable Connection: G ½ A (DIN 16288 - B6kt) 5 cable clips (black) Instruction manual PT (00 40 02 12) | 0 - 2.5 bar | 40 51 59 |
| | 0 - 4 bar | 40 51 60 |
| | 0 - 6 bar | 40 51 61 |
| | 0 - 10 bar | 40 51 62 |
| | 0 - 16 bar | 40 51 63 |

| HUBA differential pressure sensor kit | | |
|--|----------------|----------------|
| Kit consisting of.. | Pressure range | Product number |
| <ul style="list-style-type: none"> 1 sensor incl. 1.5 m screened cable (7/16" connections) 1 original HUBA bracket (for wall mounting) 1 GRUNDFOS bracket (for mounting on motor) 2 M4 screws for mounting of sensor on bracket 1 M6 screw (self-cutting) for mounting on MGE 90/100 1 M8 screw (self-cutting) for mounting on MGE 112/132 2 capillary tubes (short/long) 2 brackets (1/4" - 7/16") 5 cable clips (black) | 0 - 0.6 bar | 48 54 50 |
| | 0 - 1 bar | 48 54 41 |
| | 0 - 1.6 bar | 48 54 42 |
| | 0 - 2.5 bar | 48 54 43 |
| | 0 - 4 bar | 48 54 44 |
| | 0 - 6 bar | 48 54 45 |

Potentiometer

Potentiometer for setpoint setting and start/stop of the pump.

| Product | Product number |
|--|----------------|
| External potentiometer with cabinet for wall mounting. | 62 54 68 |

R100

R100 is used for wireless communication. The communication takes place by means of infrared light.

| Product | Product number |
|---------|----------------|
| R100 | 62 53 33 |

G10-LON interface

The G10-LON interface is used in connection with data transmission between a Locally Operating Network (LON) and electronically controlled Grundfos pumps applying the Grundfos bus-protocol GENibus.

| Product | Product number |
|-------------------|----------------|
| G10-LON interface | 00 60 57 26 |

| | |
|-------------------------|-----------|
| V7 13 12 88 04 03 | GB |
| Repl. V7 13 12 88 04 01 | |

Subject to alterations.