

### Applications

- Emergency flood control
- De-watering and storm water transfer
- Irrigation and drainage
- Circulation in cooling towers

### Features

- Single stage centrifugal pump
- Back-pull-out design
- High efficiency mixed-flow type impeller
- Electric motor or engine driven

### Benefits

- Huge volumes of water using very little power
- Very low generated head
- High efficiency hydraulics
- Simple reliable design
- Good suction lift capability



### Design

Single stage centrifugal pump with end-suction and either top or side discharge, for horizontal installation.

The back-pull-out construction allows the pump to be disassembled without disturbing the suction and discharge pipework.

Impellers are of high hydraulic efficiency mixed flow design. Heavy duty bearings support a generously sized shaft, for minimum deflection and reliable long term operation.

### Operating data

Discharge flanges:	100 mm to 700 mm
Flange standard:	BS 4504 PN6
Optional flanges:	Customer's choice
Flowrate:	Up to 5000 M3/Hr
Total head:	Up to 15 metres
Max working pressure:	2 bar standard
Maximum temperature:	80 deg C standard
Minimum temperature:	-20 deg C standard

### Electric motor drive

The pump is usually supplied with a standard electric motor, complete with bedplate, coupling and guard. Motors are generally inverter driven, to obtain the exact operating speed required for the specified duty.

NEMA, Eex d, Ex(N), Energy Efficient (EFF1) and other special motors are available as options.

### Diesel engine drive

A choice of air and water cooled diesel engines may be fitted, often through a gearbox to achieve the low pump running speeds.

### Material choices

#### Casing

Cast iron	BS 1452 Grade 250
Ductile iron	BS 2789 Grade 420/12
Stainless steel	BS 970 Grade 316C15

#### Impeller

Cast iron	BS 1452 Grade 250
Gunmetal bronze	BS 1400 Grade LG4
Stainless steel	BS 970 Grade 316C15

#### Shaft

Stainless steel	BS 970 Grade 303
Stainless steel	BS 970 Grade 316

### Shaft seal

Packed gland seal or single carbon vv ceramic mechanical seal with nitrile elastomers as standard. Pumps can be fitted with a wide variety of alternative mechanical seals to suit the application.

## Features of the AMF pump range

### Quality Control....

Every pump produced by Apex is manufactured strictly to ISO 9001 quality control procedures, and complies with the most rigorous documentary requirements of demanding customers.

### ....Benefit

*The in-house engineering capability, attention to quality control and testing facilities make Apex the preferred choice for many high specification projects.*

### Enormous flowrates....

The ability to pump very high flowrates using only very low power consumption is particularly important for energy conservation. The high efficiency of the AMF range, combined with its ability to handle small quantities of soft solids makes it the pump of first choice in a wide spectrum of applications.

### ....Benefit

*Greater movement of water at the lowest possible cost, benefiting the environment and providing reduced operating costs.*

### Simple robust design....

The back-pull-out feature allows the complete rotating element to be removed for service, making maintenance simple. In addition, the removable suction cover allows access to the impeller for inspection without dismantling the pump.

### ....Benefit

*Longer life and reliable operation, with the capability to operate in harsh environments where maintenance procedures can be carried out without specialist equipment.*

### Added protection....

Pumps are available with a special internal coating of Belzona, which not only enhances the efficiency of the pump, but also protects the internal surfaces from corrosion and erosion.

### ....Benefit

*Pumps operating on seawater can be manufactured in cast iron for low cost. The Belzona coating is non toxic to marine life making it particularly suitable for marine aquaria and fish farm applications.*

### Engineering skills....

Apex engineers have the ability and experience to manufacture special pumps, using standard components wherever possible, to produce pumps that exactly match the customer's requirements.

### ....Benefit

*Pump users benefit by the broad engineering experience at Apex, and our familiarity with difficult applications and demanding duties.*

### Competitive Prices....

As a specialist manufacturer of centrifugal pumps, all Apex products are designed to be highly competitive without compromise to quality and good engineering practice.

### ....Benefit

*Apex fully supports its pump distributor network and customers by providing cost effective solutions to pumping problems.*

# Range Chart (variable speed)

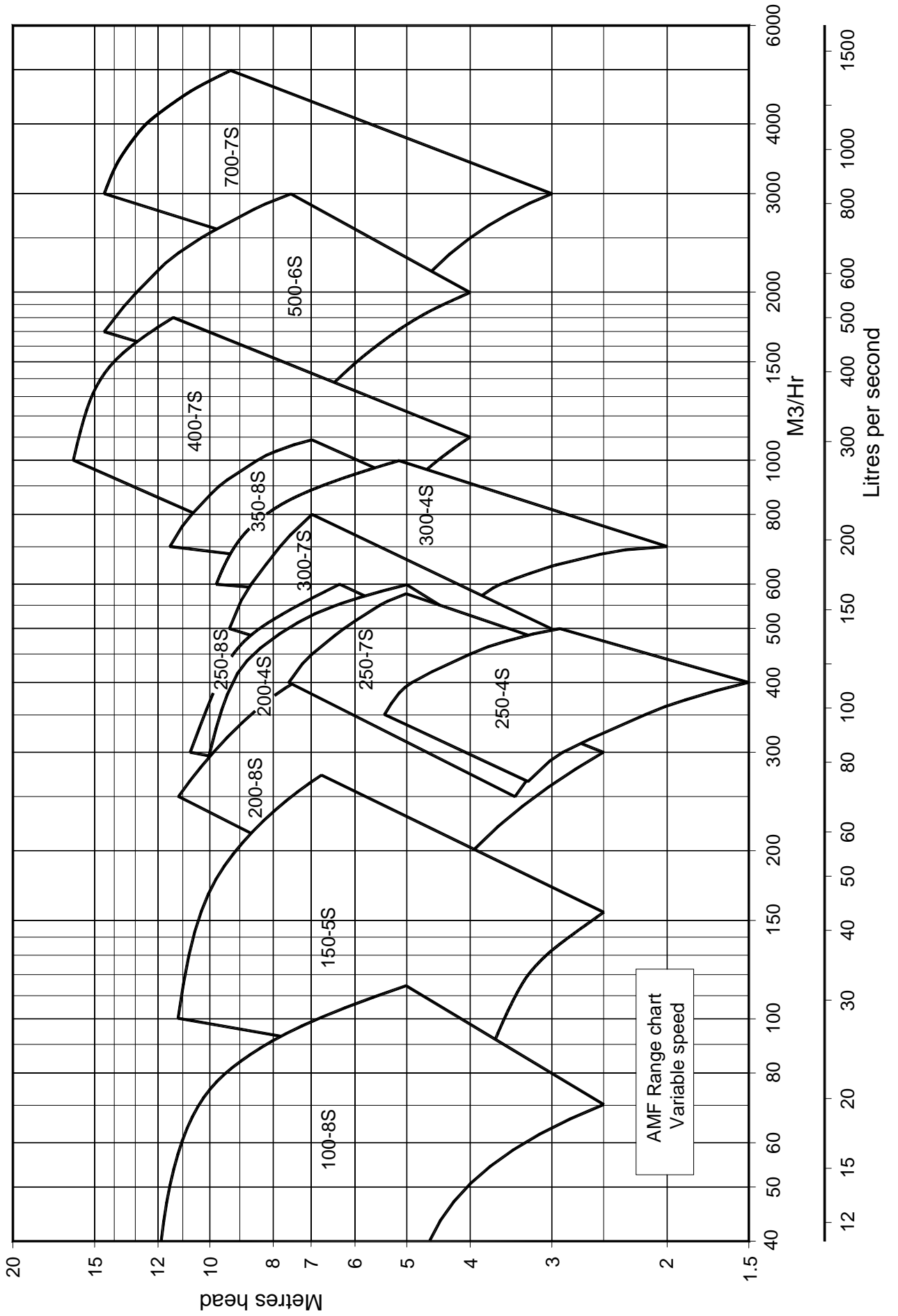

## Typical cross section (packed gland seal)

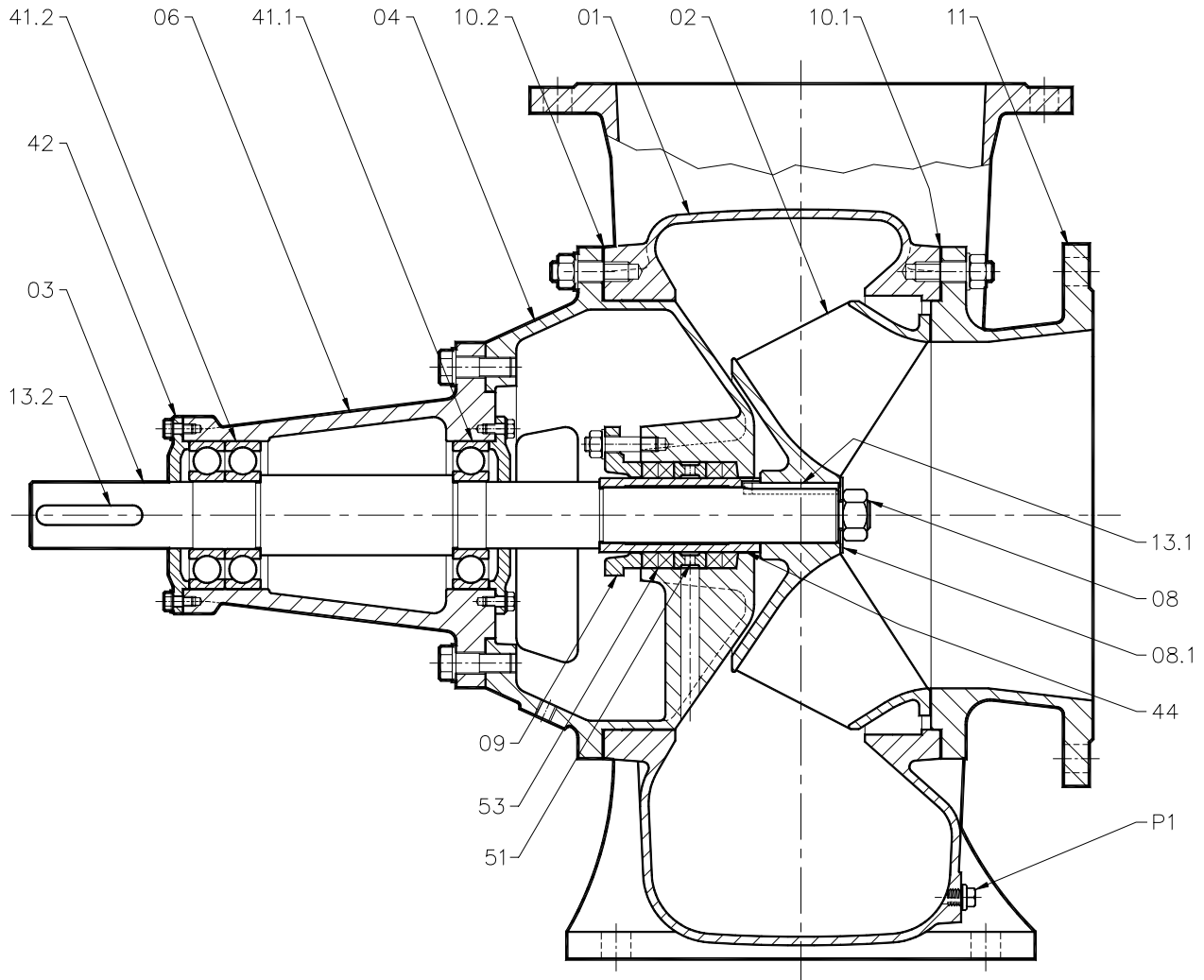

Ref	Item	Build code C	Build code B	Build code M	Build code 6
01	Volute casing	Cast iron	Cast iron	Cast iron	316 SS
02	Impeller	Cast iron	Bronze	316 SS	316 SS
03	Shaft	303 SS	303 SS	316 SS	316 SS
04	Back cover	Cast iron	Cast iron	Cast iron	316 SS
06	Bearing housing	Cast iron	Cast iron	Cast iron	Cast iron
08	Impeller nut	Steel	Steel	316 SS	316 SS
08.1	Impeller nut washer	Steel	Steel	316 SS	316 SS
09	Gland	Cast iron	Cast iron	Cast iron	316 SS
10.1	Casing gasket (front)	Gasket paper	Gasket paper	Gasket paper	Gasket paper
10.2	Casing gasket (rear)	Gasket paper	Gasket paper	Gasket paper	Gasket paper
11	Suction cover	Cast iron	Cast iron	Cast iron	316 SS
13.1	Impeller key	Key steel	Key steel	Key steel	316 SS
13.2	Coupling key	Key steel	Key steel	Key steel	Key steel
41.1	Bearing (non-drive end)	Steel	Steel	Steel	Steel
41.2	Bearing (drive end)	Steel	Steel	Steel	Steel
42	Bearing cover	Cast iron	Cast iron	Cast iron	Cast iron
44	Shaft sleeve	303 SS	303 SS	303 SS	316 SS
51	Lantern ring	Cast iron	Cast iron	Cast iron	316 SS
53	Gland packing	Cotton/graphite	Cotton/graphite	Cotton/graphite	Cotton/graphite
P1	Casing drain plug	Steel	Steel	Steel	316 SS

## Typical cross section (mechanical seal)

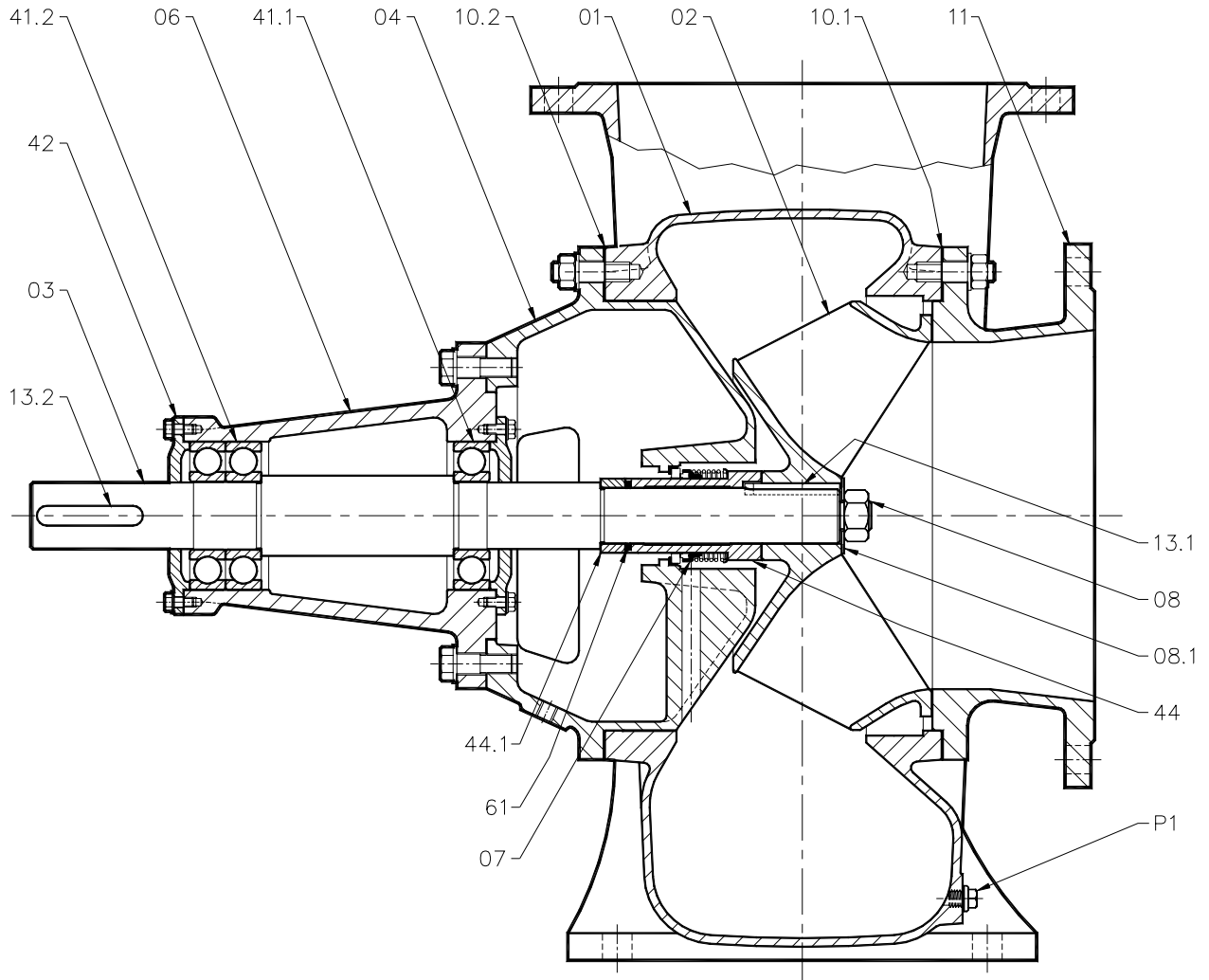

Ref	Item	Build code C	Build code B	Build code M	Build code 6
01	Volute casing	Cast iron	Cast iron	Cast iron	316 SS
02	Impeller	Cast iron	Bronze	316 SS	316 SS
03	Shaft	303 SS	303 SS	316 SS	316 SS
04	Back cover	Cast iron	Cast iron	Cast iron	316 SS
06	Bearing housing	Cast iron	Cast iron	Cast iron	Cast iron
08	Impeller nut	Steel	Steel	316 SS	316 SS
08.1	Impeller nut washer	Steel	Steel	316 SS	316 SS
09	Gland	Cast iron	Cast iron	Cast iron	316 SS
10.1	Casing gasket (front)	Gasket paper	Gasket paper	Gasket paper	Gasket paper
10.2	Casing gasket (rear)	Gasket paper	Gasket paper	Gasket paper	Gasket paper
11	Suction cover	Cast iron	Cast iron	Cast iron	316 SS
13.1	Impeller key	Key steel	Key steel	Key steel	316 SS
13.2	Coupling key	Key steel	Key steel	Key steel	Key steel
41.1	Bearing (non-drive end)	Steel	Steel	Steel	Steel
41.2	Bearing (drive end)	Steel	Steel	Steel	Steel
42	Bearing cover	Cast iron	Cast iron	Cast iron	Cast iron
44	Shaft sleeve	303 SS	303 SS	303 SS	316 SS
51	Lantern ring	Cast iron	Cast iron	Cast iron	316 SS
53	Gland packing	Cotton/graphite	Cotton/graphite	Cotton/graphite	Cotton/graphite
P1	Casing drain plug	Steel	Steel	Steel	316 SS

## Casing data

Pump size	Suction size mm	Discharge size mm	Casing thickness mm	Max working pressure Bar	Max test pressure bar	Max suction pressure bar	Flange PN rating Bar
100-8s	100	100	6.0	2.0	3.0	1.0	6 bar
150-5s	150	150	6.0	2.0	3.0	1.0	6 bar
200-4s	200	200	6.0	2.0	3.0	1.0	6 bar
200-8s	200	200	6.0	2.0	3.0	1.0	6 bar
250-4s	250	250	7.0	2.0	3.0	1.0	6 bar
250-7s	250	250	7.0	2.0	3.0	1.0	6 bar
250-8s	250	250	7.0	2.0	3.0	1.0	6 bar
300-4s	300	300	7.0	2.0	3.0	1.0	6 bar
300-7s	300	300	7.0	2.0	3.0	1.0	6 bar
350-8s	350	350	7.0	2.0	3.0	1.0	6 bar
400-7s	400	400	10	2.0	3.0	1.0	6 bar
500-6s	500	500	12	2.0	3.0	1.0	6 bar
700-7s	700	700	12	2.0	3.0	1.0	6 bar

## Flange data

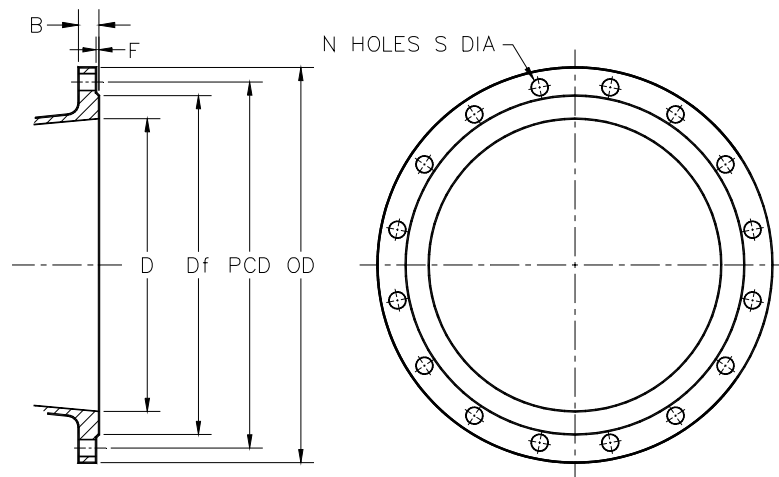

Flanges to BS4504 PN6

D	OD	B	Df	F	N	S	PCD
100	210	16	148	3	4	18	170
150	265	18	202	3	8	18	225
200	320	19	258	3	8	18	280
250	375	20	312	3	12	18	335
300	440	22	365	4	12	22	395
350	490	22	415	4	12	22	445
400	540	22	465	4	16	22	495
500	645	24	570	4	20	22	600
700	860	24	775	5	24	26	810

## Impeller data

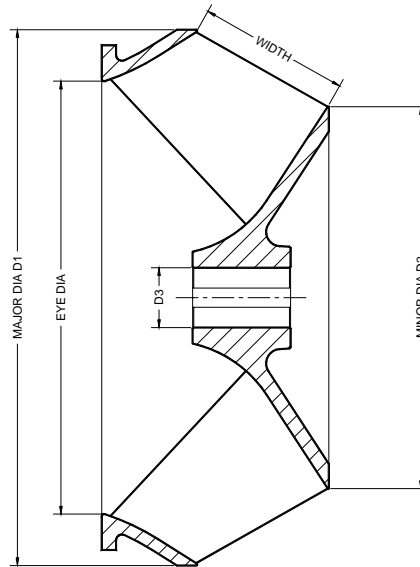

Pump size	Eye dia mm	Major dia D1 mm	Minor dia D2 mm	Hub dia D3 mm	Width mm	Max soft solids mm
100-8s	96	130	110	20	40	10
150-5s	150	190	140	25	51	12
200-4s	196	248	190	30	67	16
200-8s	187	238	178	30	61	15
250-4s	220	282	207	40	75	19
250-7s	240	304	224	40	77	18
250-8s	230	290	210	40	74	16
300-4s	280	347	261	45	98	24
300-7s	270	341	262	45	88	22
350-8s	294	376	278	45	94	24
400-7s	362	448	322	50	122	30
500-6s	438	556	400	55	140	35
700-7s	610	790	610	90	180	40

## Shaft and bearing data

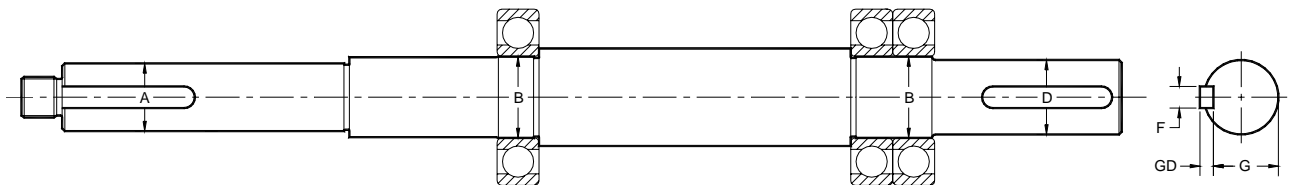

Dimensions in mm

Pump model	Bearing size	A Diameter at impeller	B Diameter at bearing	D Diameter at coupling	F x GD Coupling key width x depth	G Keyway depth
100-8s	6305	20	25	24	8 x 7	20
150-5s	6306	25	30	30	8 x 7	26
200-4s	6308	30	40	35	10 x 8	30
200-8s	6308	30	40	35	10 x 8	30
250-4s	6309	40	45	44	14 x 9	39
250-7s	6309	40	45	44	14 x 9	39
250-8s	6309	40	45	44	14 x 9	39
300-4s	6311	45	55	54	16 x 10	48
300-8s	6311	45	55	54	16 x 10	48
350-8s	6311	45	55	54	16 x 10	48
400-7s	6312	50	60	55	16 x 10	49
500-6s	6314	55	70	68	20 x 12	60.5
700-7s	46322	90	110	95	28 x 16	85

## Packed gland data

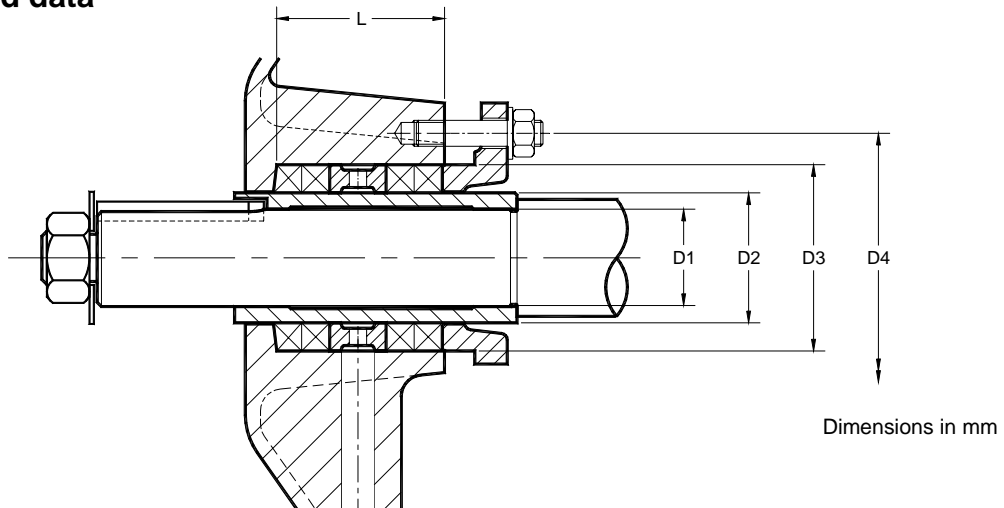

Pump size	Shaft dia D1	Sleeve dia D2	Box bore D3	Stud PCD D4	Gland studs Quantity x size	Stuffing box length L	Packing ring size
100-8s	20	32	48	62	2 x M8	47.0	8 mm square
150-5s	25	39	55	68	2 x M8	47.0	8 mm square
200-4s	32	50	70	100	2 x M10	42.0	10 mm square
200-8s	32	50	70	100	2 x M10	42.0	10 mm square
250-4s	40	60	86	115	2 x M12	78.5	13 mm square
250-7s	40	60	86	115	2 x M12	78.5	13 mm square
250-8s	40	60	86	115	2 x M12	78.5	13 mm square
300-4s	45	60	86	115	2 x M12	77.5	13 mm square
300-7s	45	60	86	115	2 x M12	77.5	13 mm square
350-8s	45	60	86	115	2 x M12	78.5	13 mm square
400-7s	50	70	96	135	2 x M16	70.0	13 mm square
500-6s	55	80	112	150	2 x M16	88.0	15 mm square
700-7s	90	120	160	210	2 x M16	100	20 mm square

## Mechanical seal data

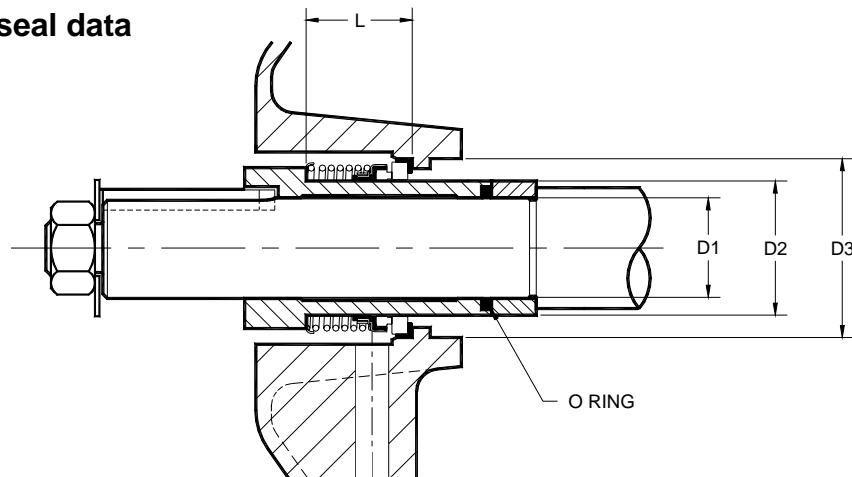

Pump size	Shaft dia D1	Sleeve dia D2	Stationary bore D3	O ring size	Seal length L	Mechanical seal size
100-8s	20	30	45	20 x 2.5	42.5	30 AN
150-5s	25	35	50	25 x 2.5	42.5	35 AN
200-4s	32	45	63	32 x 2.5	45.0	45 AN
200-8s	32	45	63	32 x 2.5	45.0	45 AN
250-4s	40	50	70	40 x 2.5	47.5	50 AN
250-7s	40	50	70	40 x 2.5	47.5	50 AN
250-8s	40	50	70	40 x 2.5	47.5	50 AN
300-4s	45	55	75	45 x 2.5	47.5	55 AN
300-7s	45	55	75	45 x 2.5	47.5	55 AN
350-8s	45	55	75	45 x 2.5	47.5	55 AN
400-7s	50	60	80	50 x 2.5	52.5	60 AN
500-6s	55	65	85	55 x 2.5	52.5	65 AN
700-7s	90	100	120	90 x 2.5	94.0	100 AN

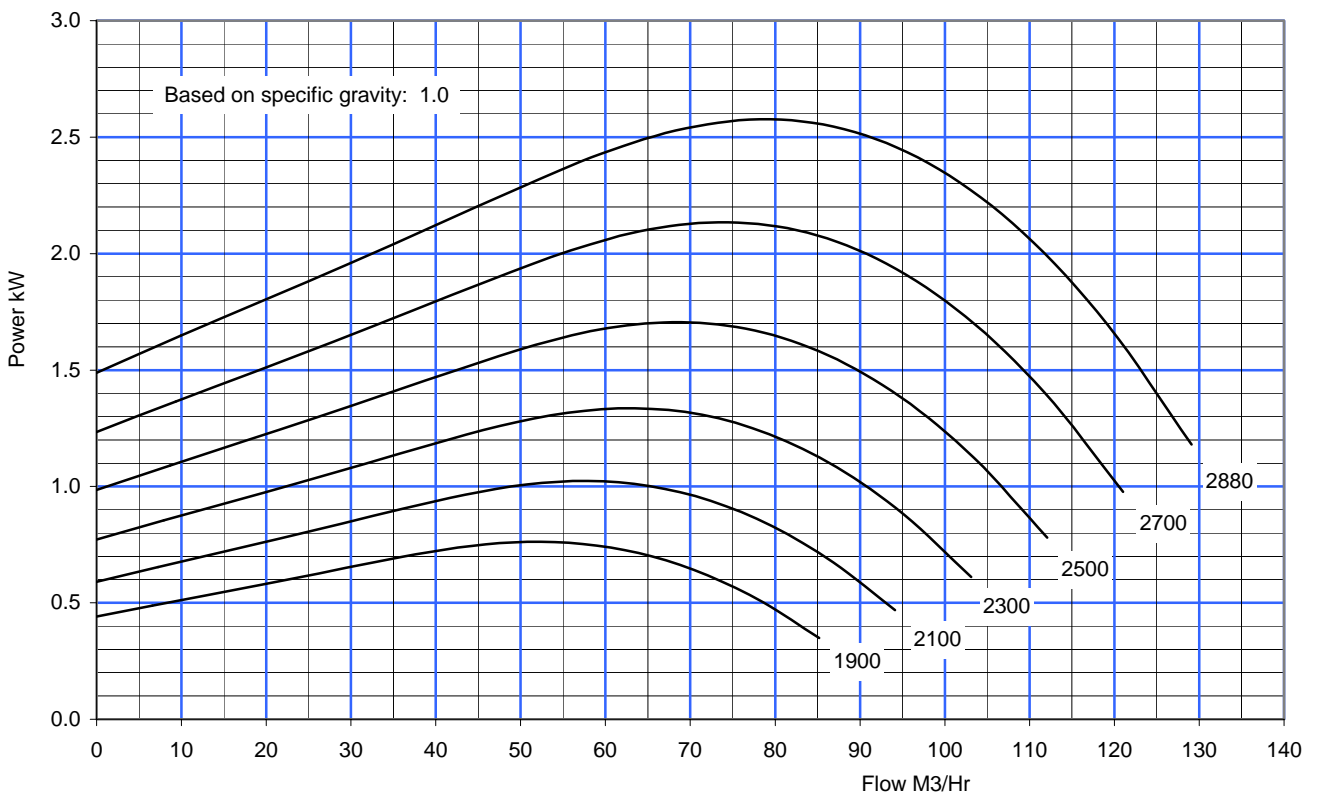
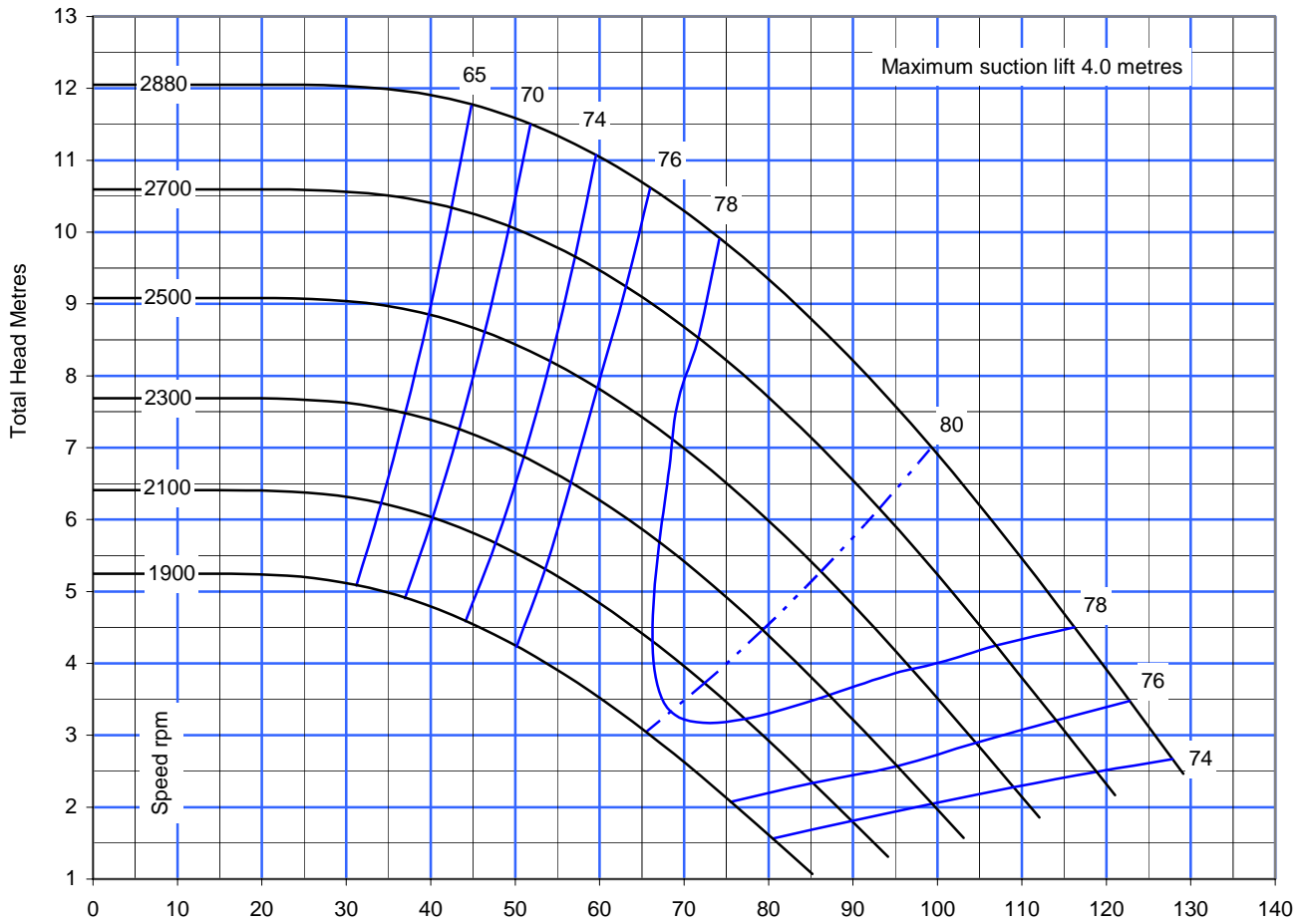

SUCTION DIA <b>100</b>	DISCHARGE DIA <b>100</b>	MAX PRESSURE <b>2 bar</b>	PUMP MODEL <b>AMF 100-8S</b>	WEIGHT <b>30 kg</b>
---------------------------	-----------------------------	------------------------------	---------------------------------	------------------------

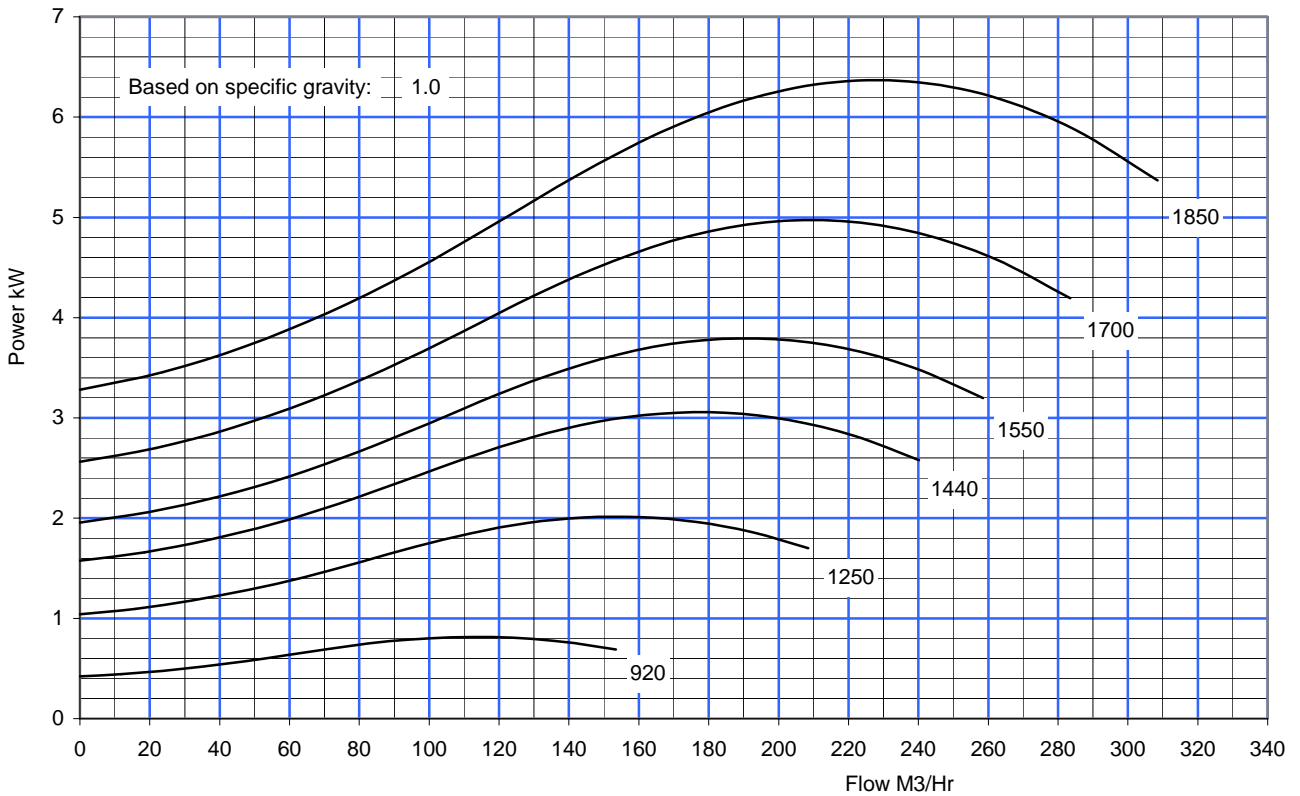
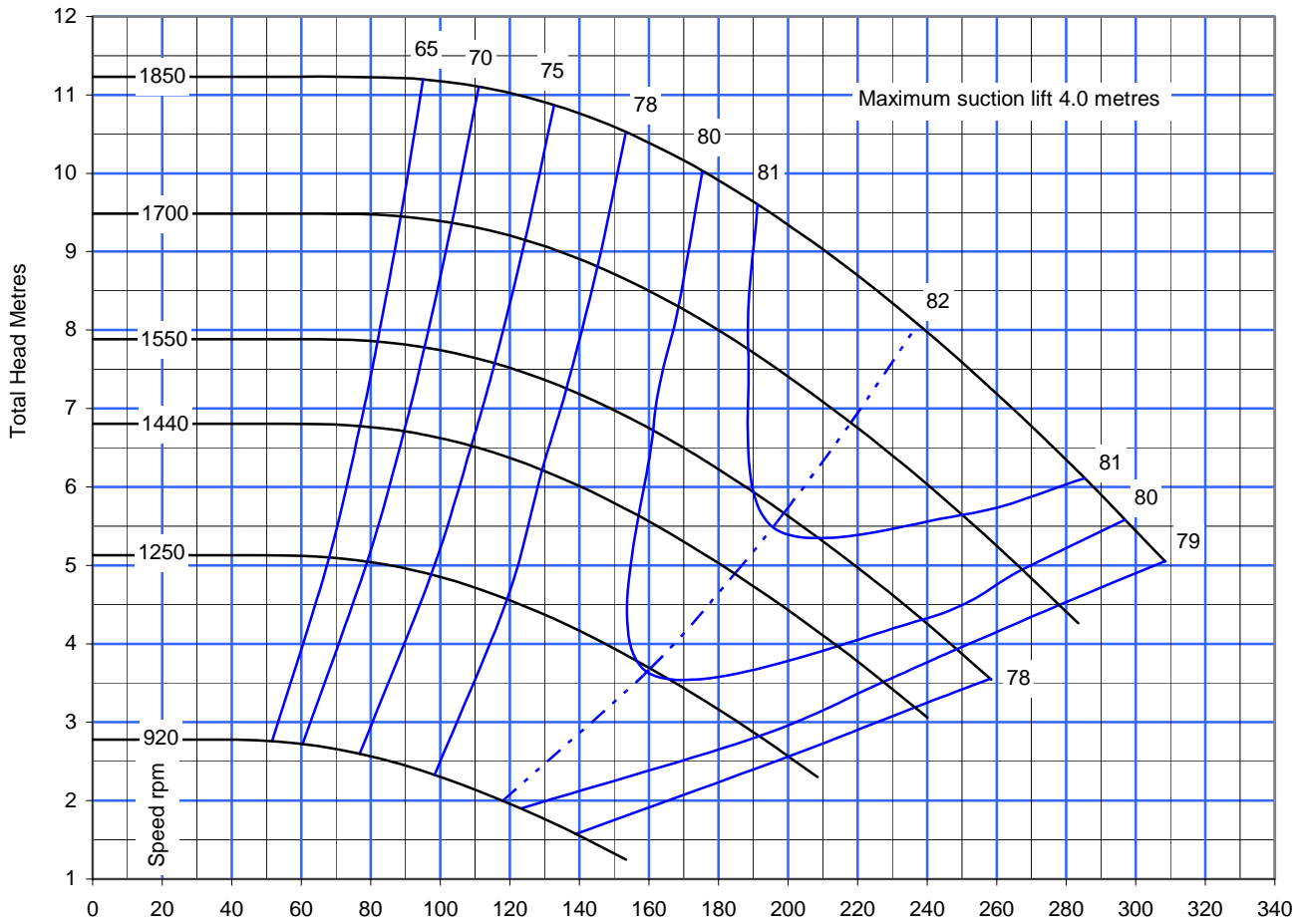

SUCTION DIA <b>150</b>	DISCHARGE DIA <b>150</b>	MAX PRESSURE <b>2 bar</b>	PUMP MODEL <b>AMF 150-5S</b>	WEIGHT <b>65 kg</b>
---------------------------	-----------------------------	------------------------------	---------------------------------	------------------------

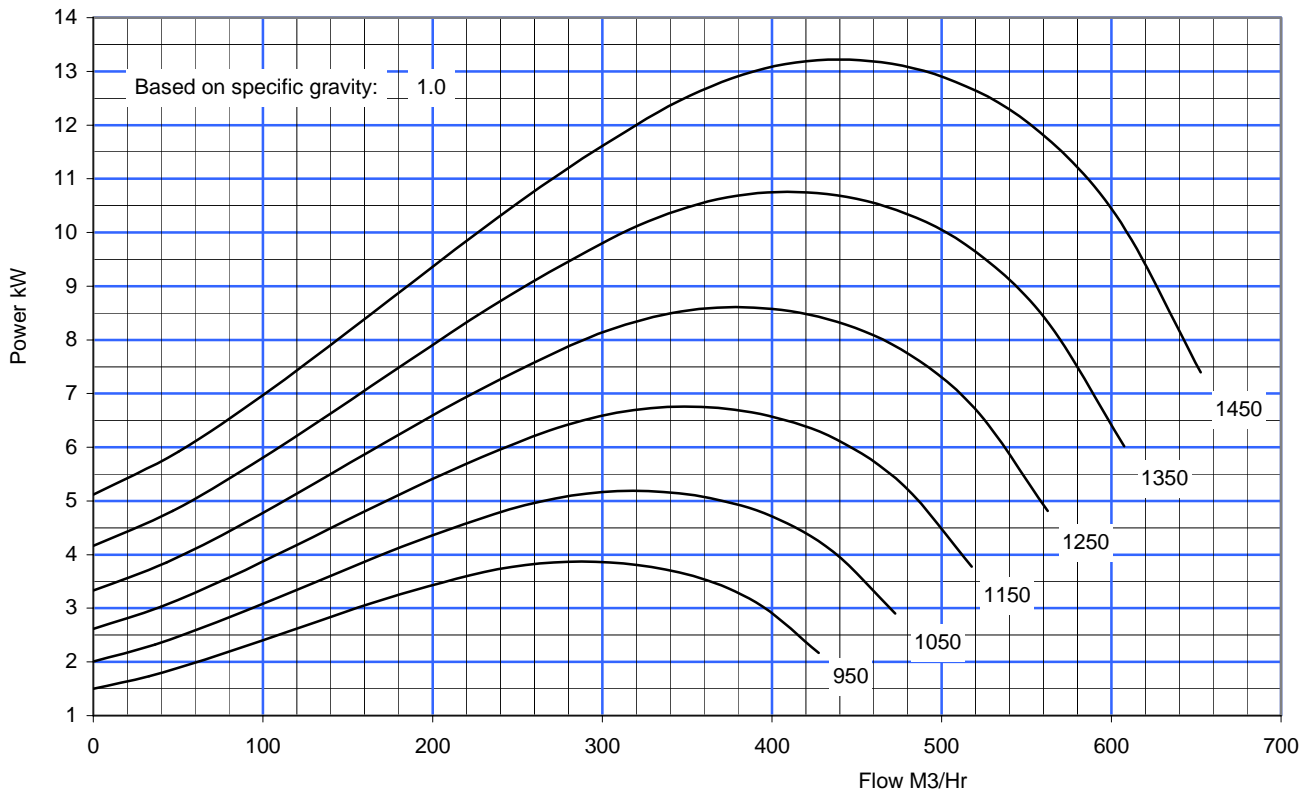
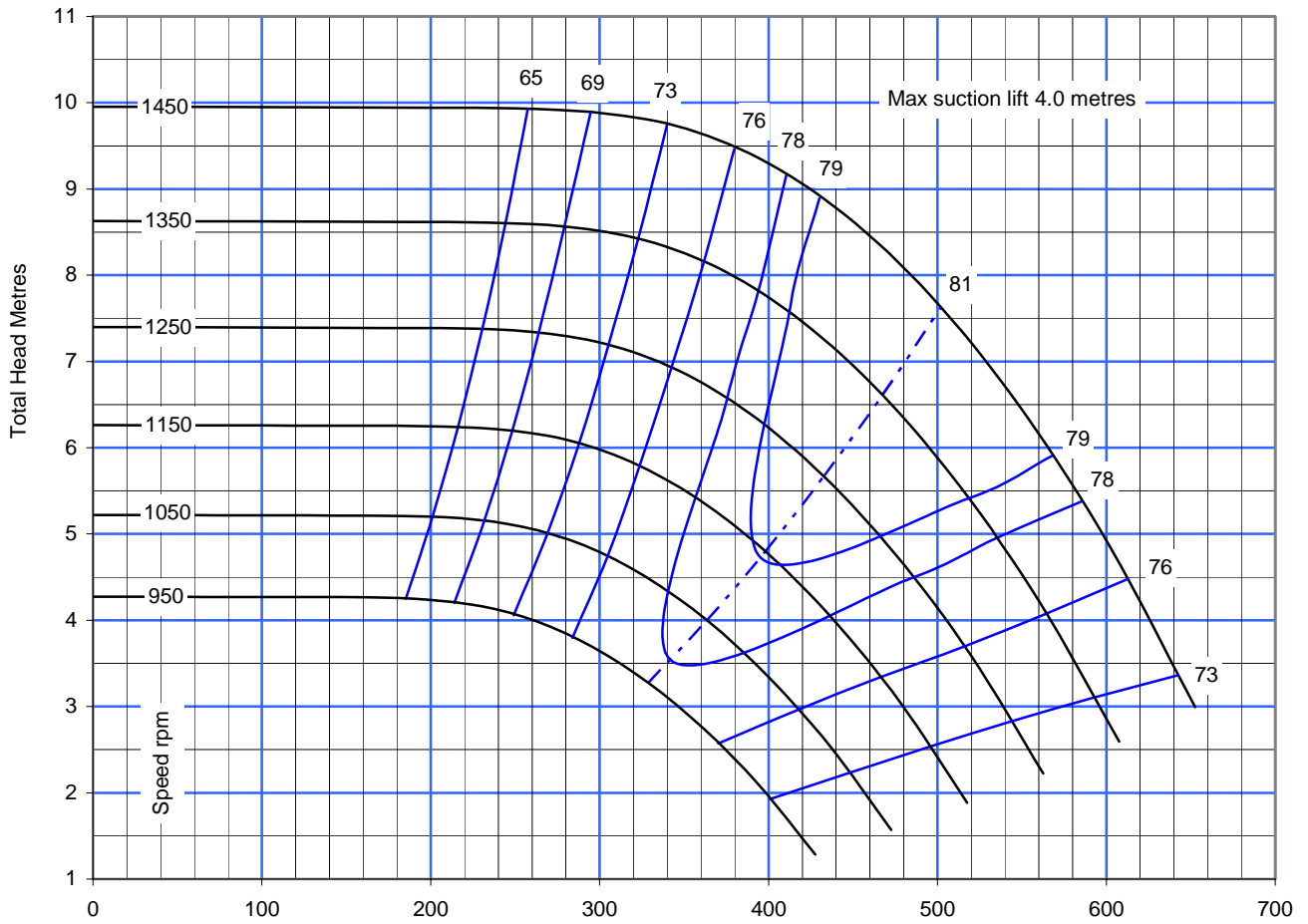

SUCTION DIA <b>200</b>	DISCHARGE DIA <b>200</b>	MAX PRESSURE <b>2 bar</b>	PUMP MODEL <b>AMF 200-4S</b>	WEIGHT <b>110 kg</b>
---------------------------	-----------------------------	------------------------------	---------------------------------	-------------------------

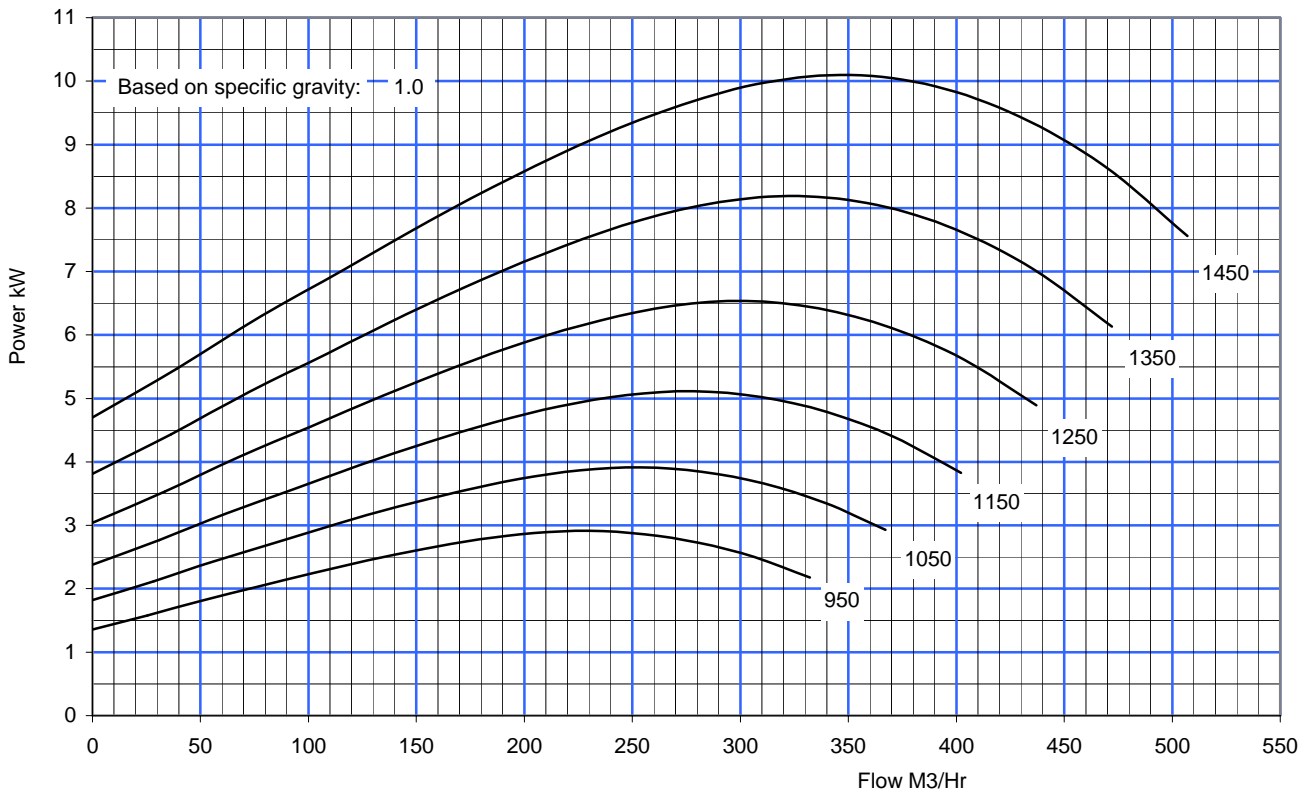
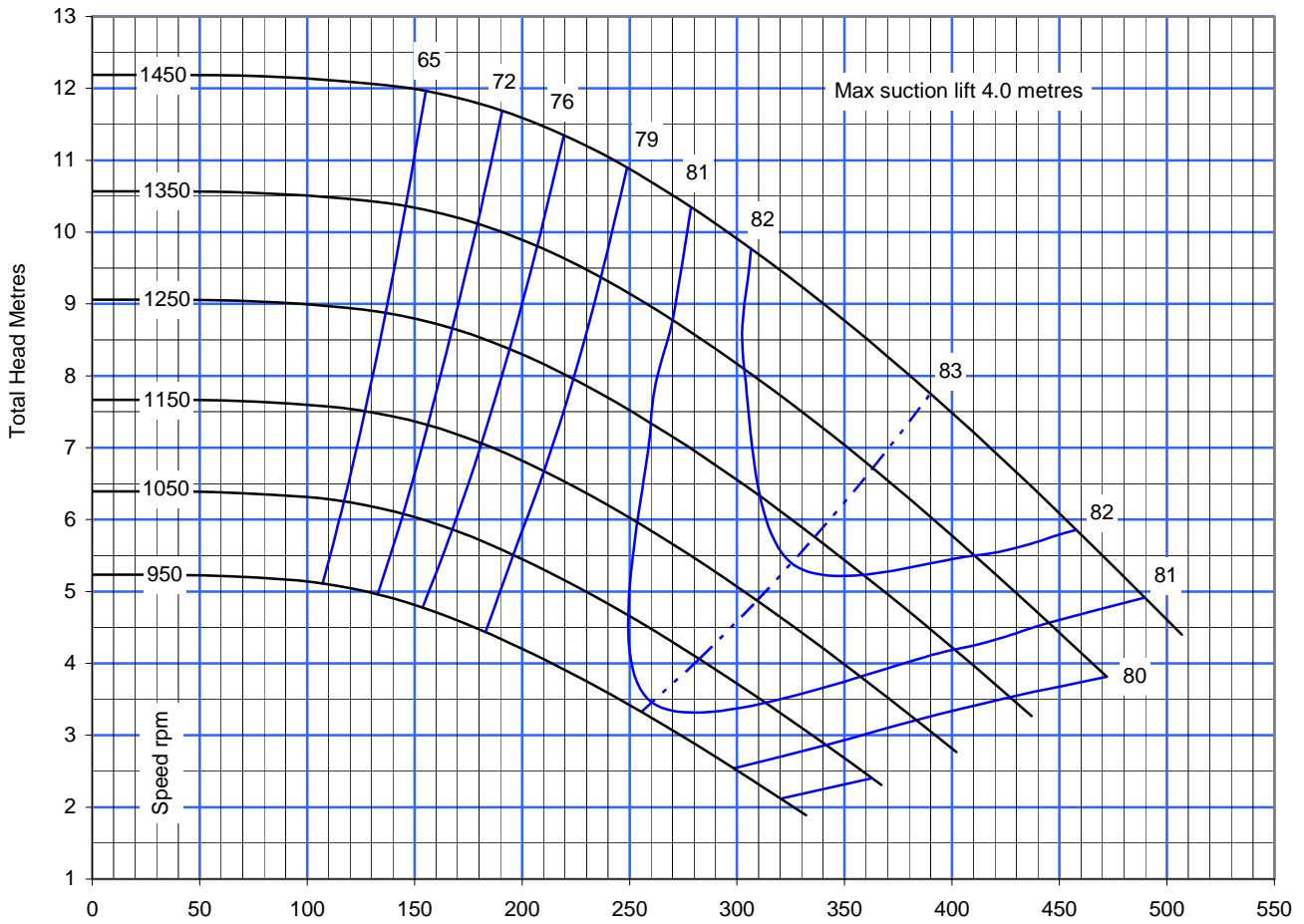

SUCTION DIA <b>200</b>	DISCHARGE DIA <b>200</b>	MAX PRESSURE <b>2 bar</b>	PUMP MODEL <b>AMF 200-8s</b>	WEIGHT <b>110 kg</b>
---------------------------	-----------------------------	------------------------------	---------------------------------	-------------------------

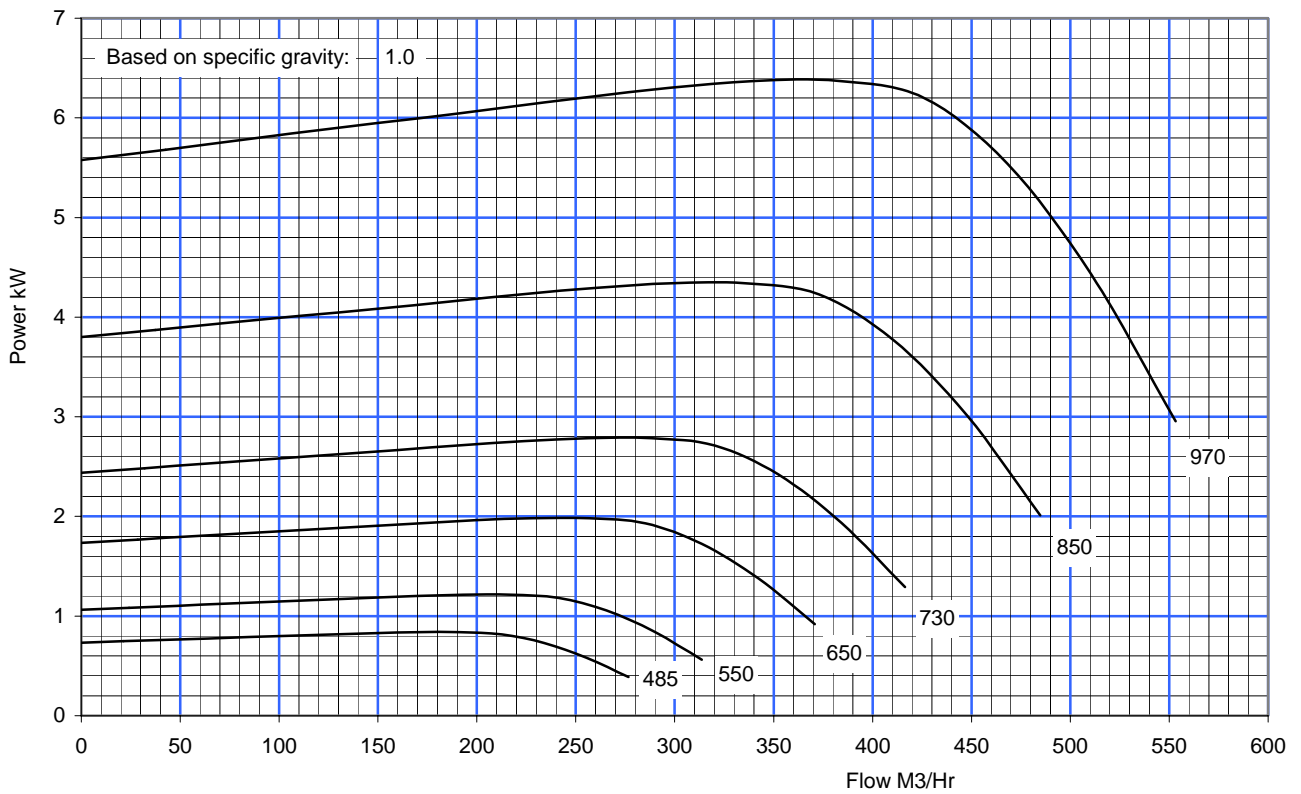
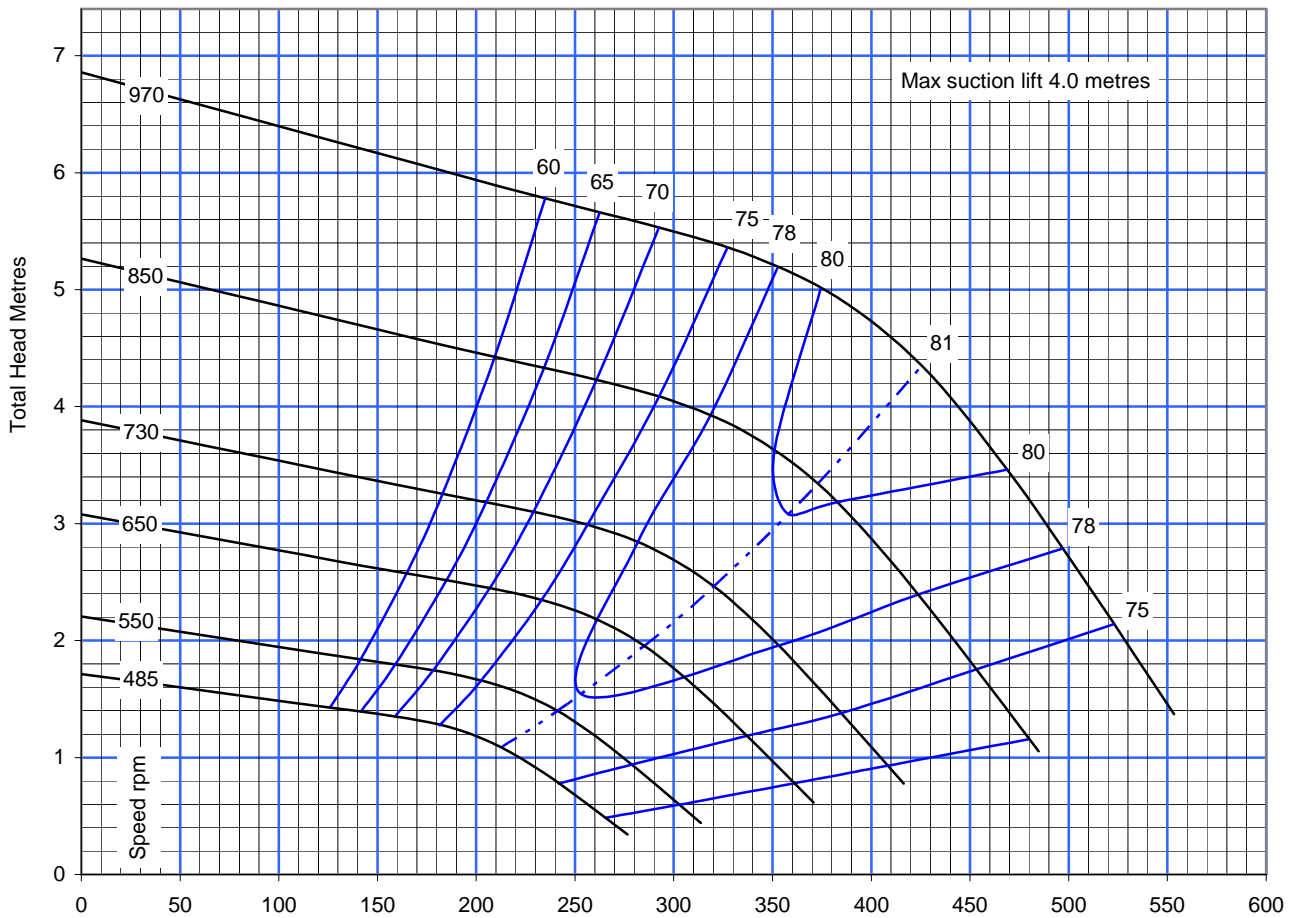

SUCTION DIA <b>250</b>	DISCHARGE DIA <b>250</b>	MAX PRESSURE <b>2 bar</b>	PUMP MODEL <b>AMF 250-4S</b>	WEIGHT <b>165 kg</b>
---------------------------	-----------------------------	------------------------------	---------------------------------	-------------------------

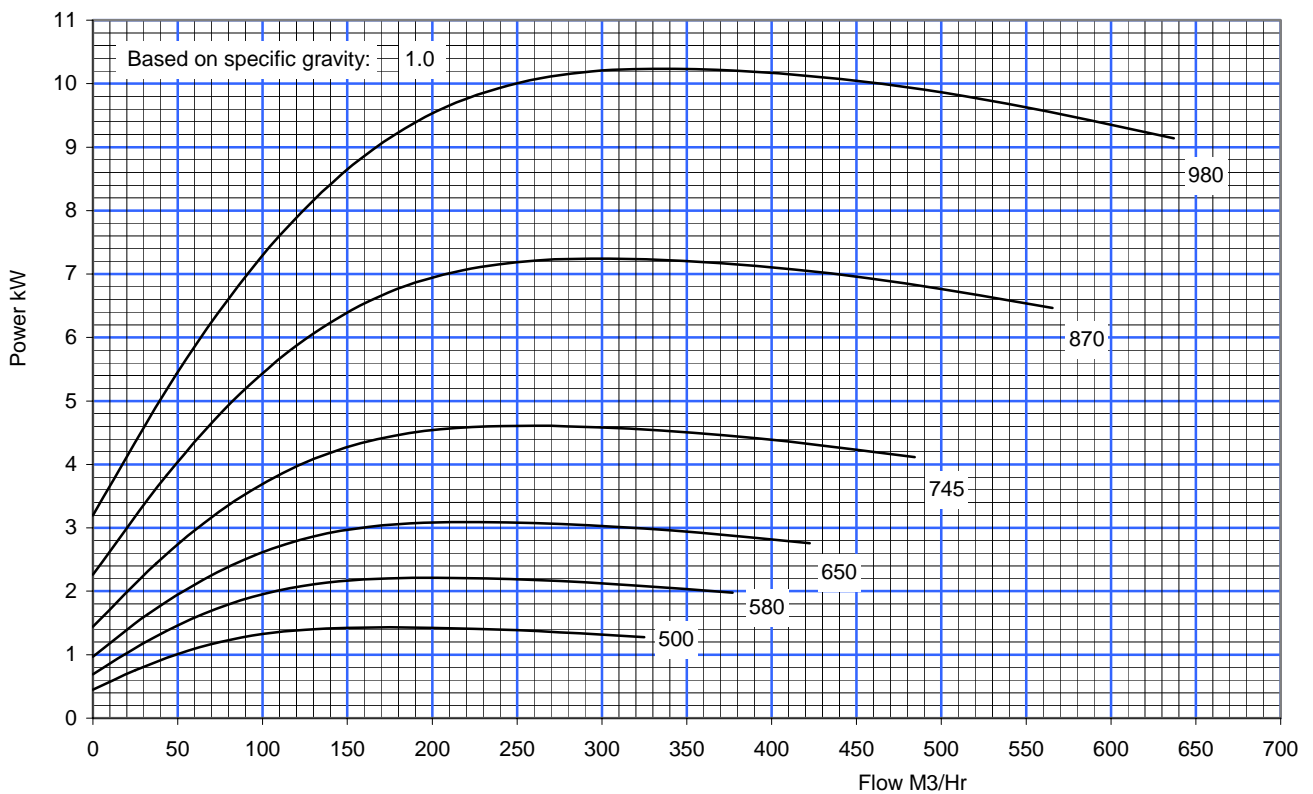
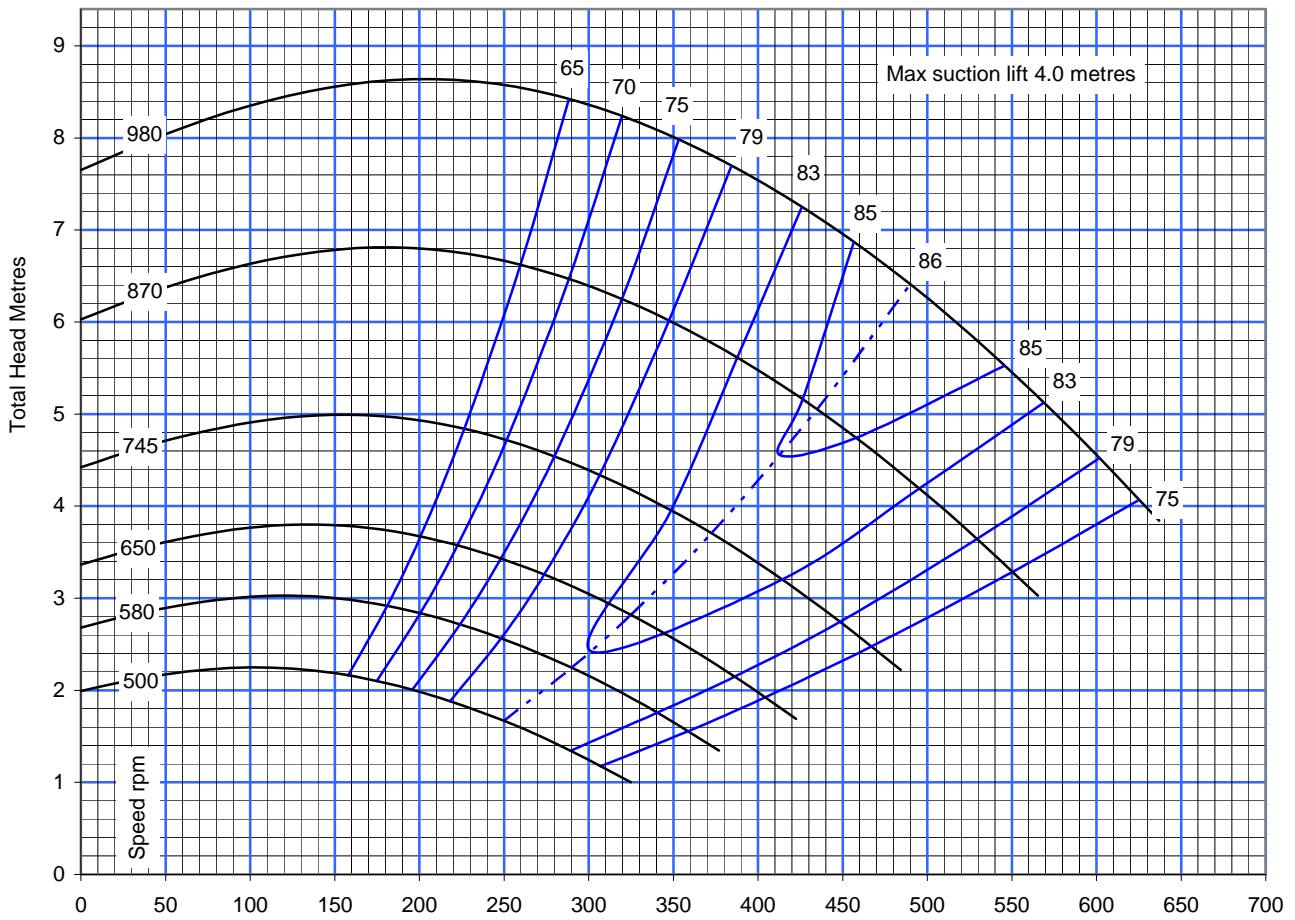

SUCTION DIA <b>250</b>	DISCHARGE DIA <b>250</b>	MAX PRESSURE <b>2 bar</b>	PUMP MODEL <b>AMF 250-7S</b>	WEIGHT <b>165 kg</b>
---------------------------	-----------------------------	------------------------------	---------------------------------	-------------------------

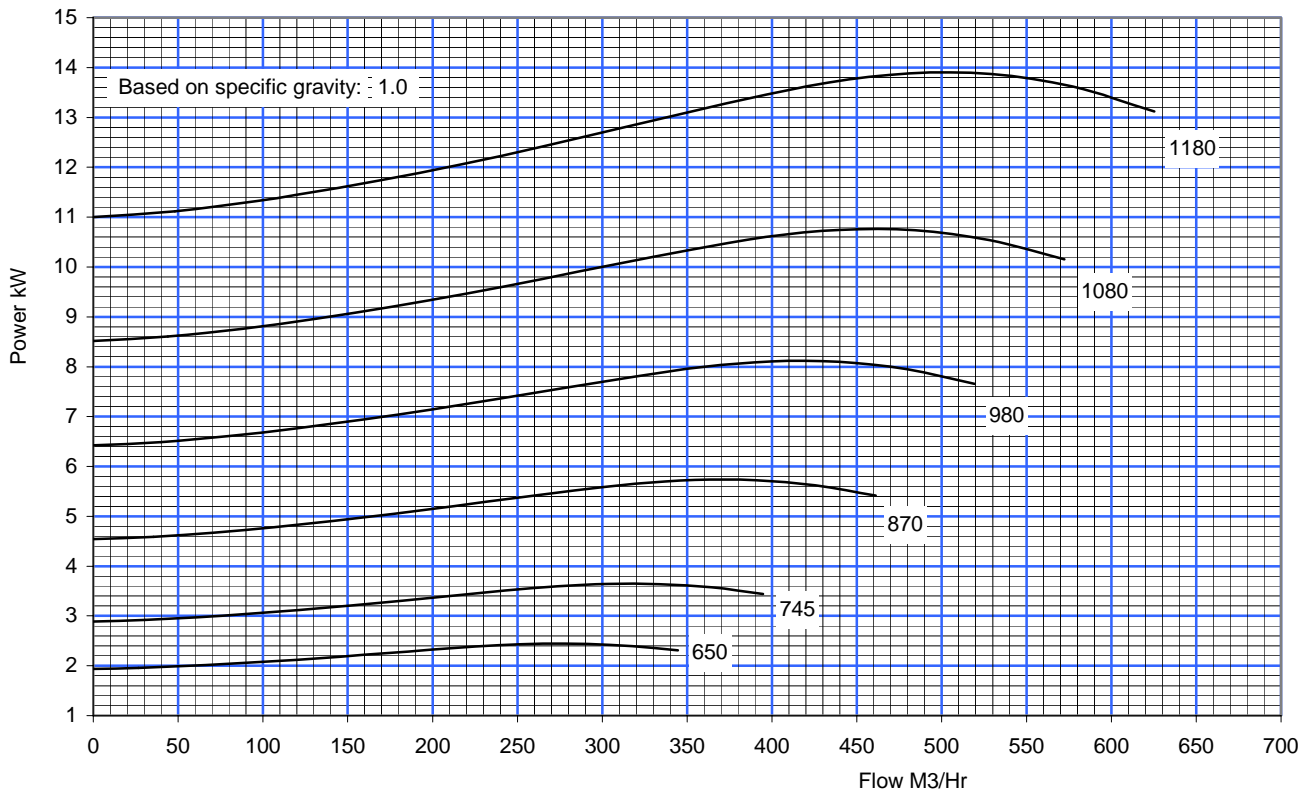
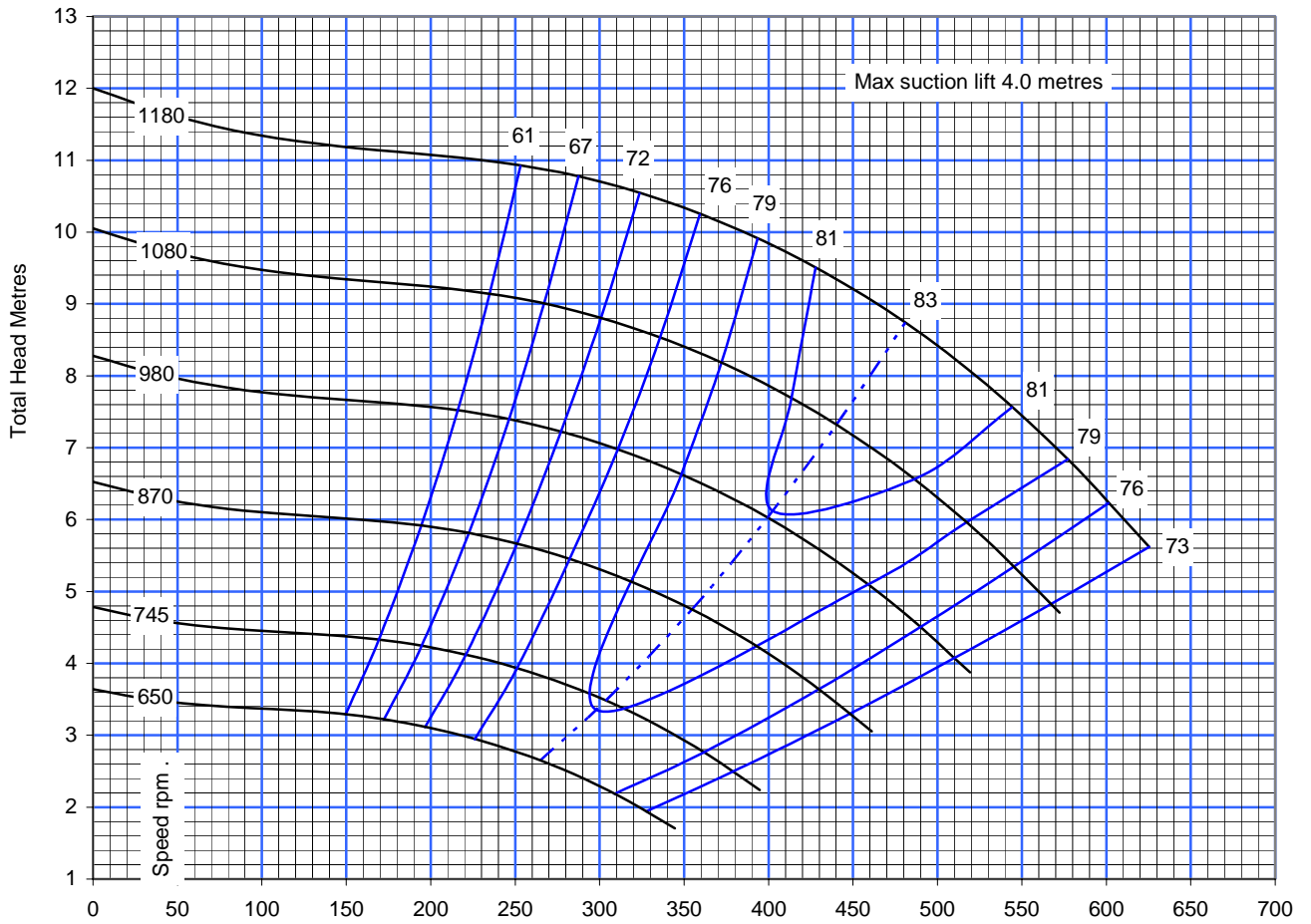

SUCTION DIA <b>250</b>	DISCHARGE DIA <b>250</b>	MAX PRESSURE <b>2 bar</b>	PUMP MODEL <b>AMF 250-8S</b>	WEIGHT <b>165 kg</b>
---------------------------	-----------------------------	------------------------------	---------------------------------	-------------------------

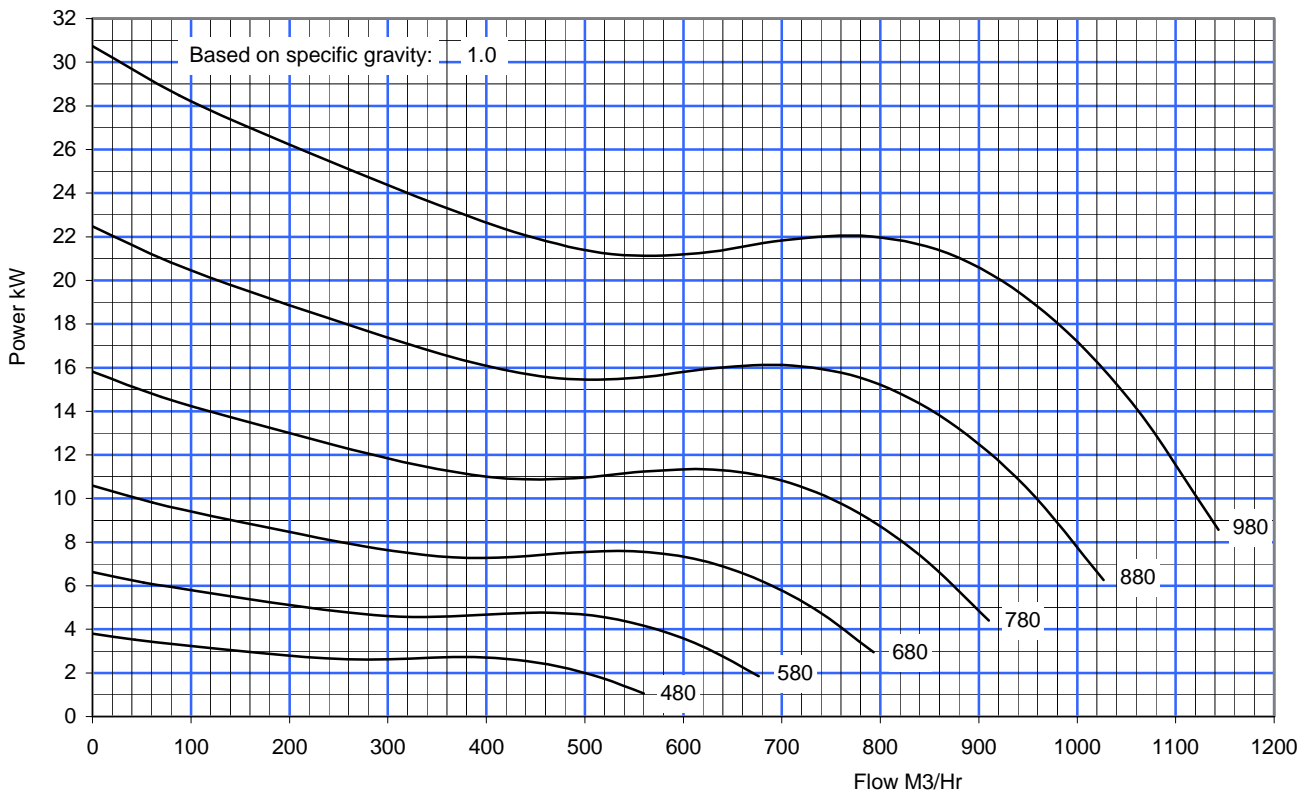
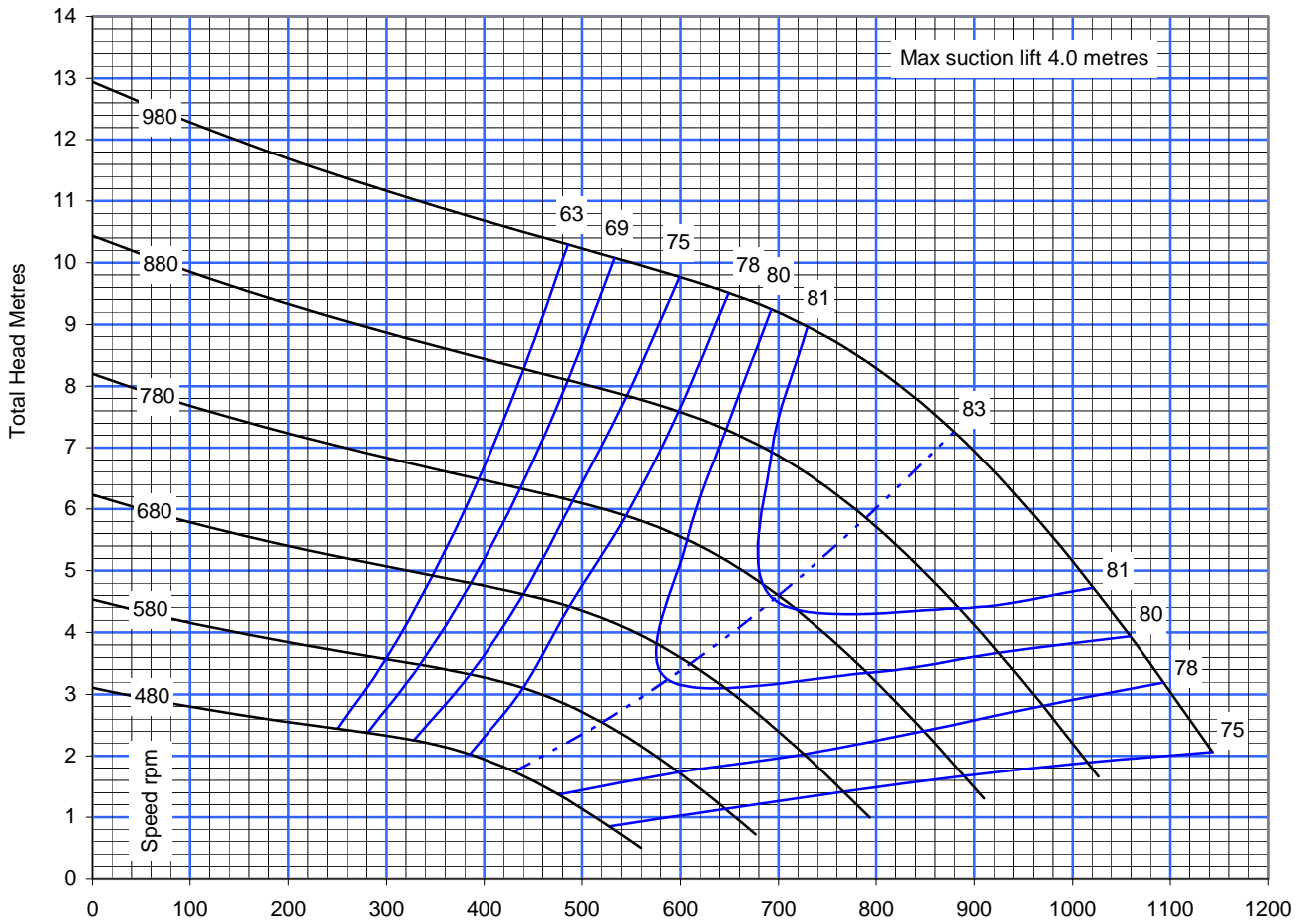

SUCTION DIA <b>300</b>	DISCHARGE DIA <b>300</b>	MAX PRESSURE <b>2 bar</b>	PUMP MODEL <b>AMF 300-4S</b>	WEIGHT <b>195 kg</b>
---------------------------	-----------------------------	------------------------------	---------------------------------	-------------------------

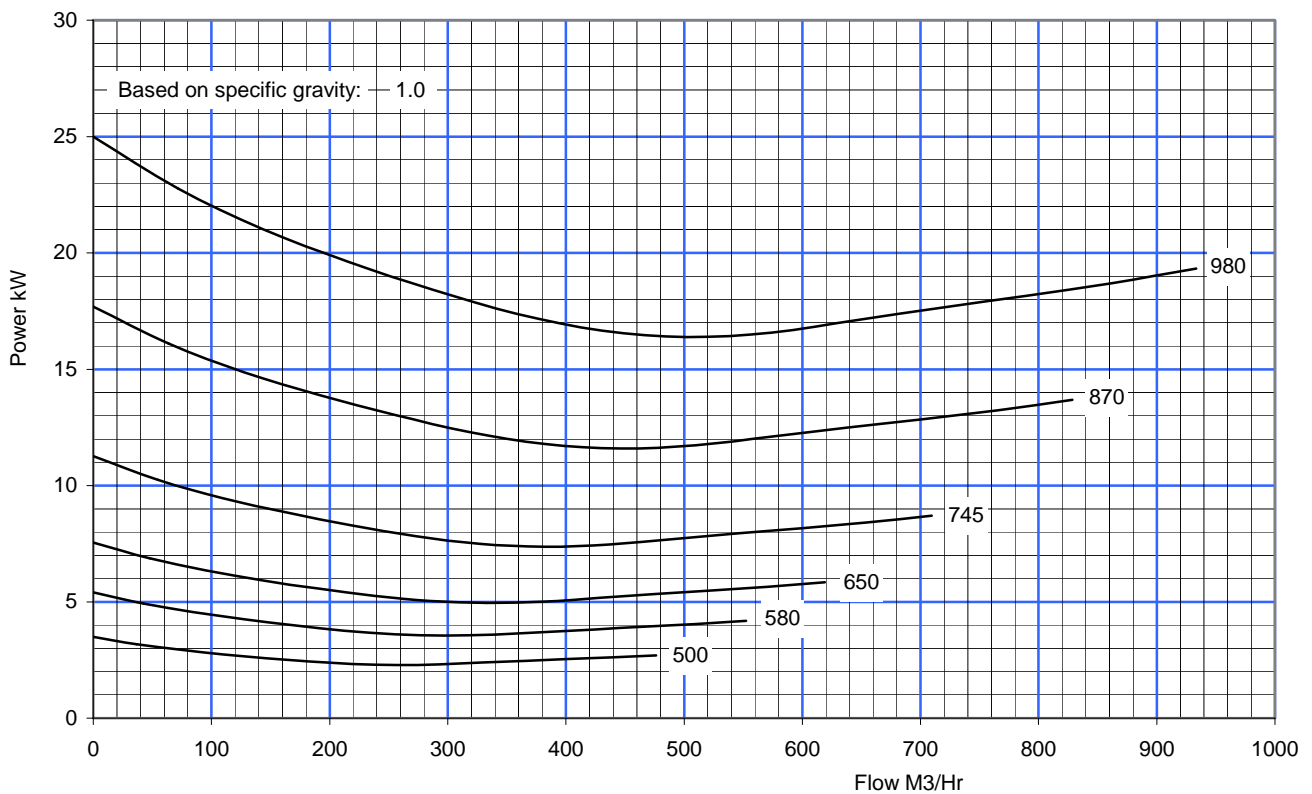
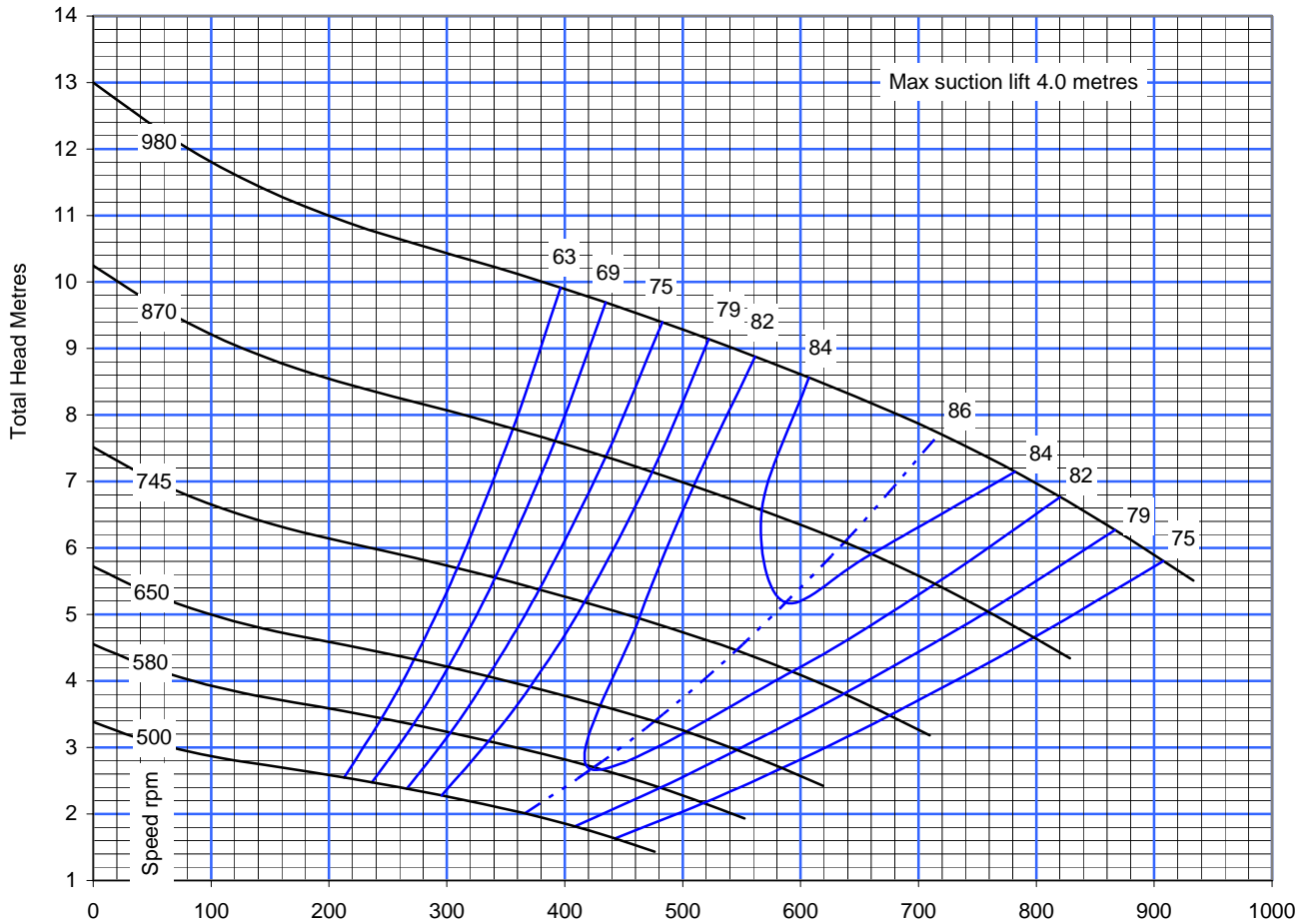

SUCTION DIA <b>300</b>	DISCHARGE DIA <b>300</b>	MAX PRESSURE <b>2 bar</b>	PUMP MODEL <b>AMF 300-7S</b>	WEIGHT <b>195 kg</b>
---------------------------	-----------------------------	------------------------------	---------------------------------	-------------------------

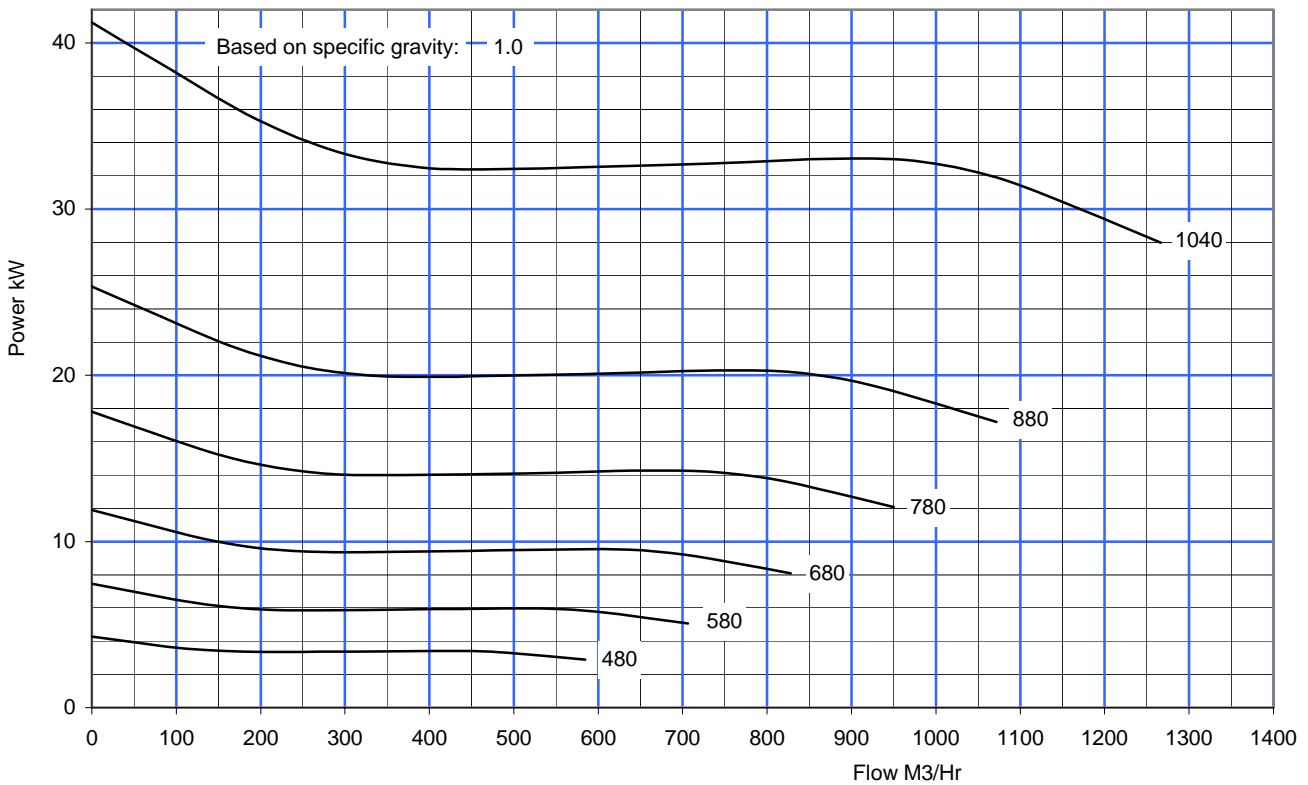
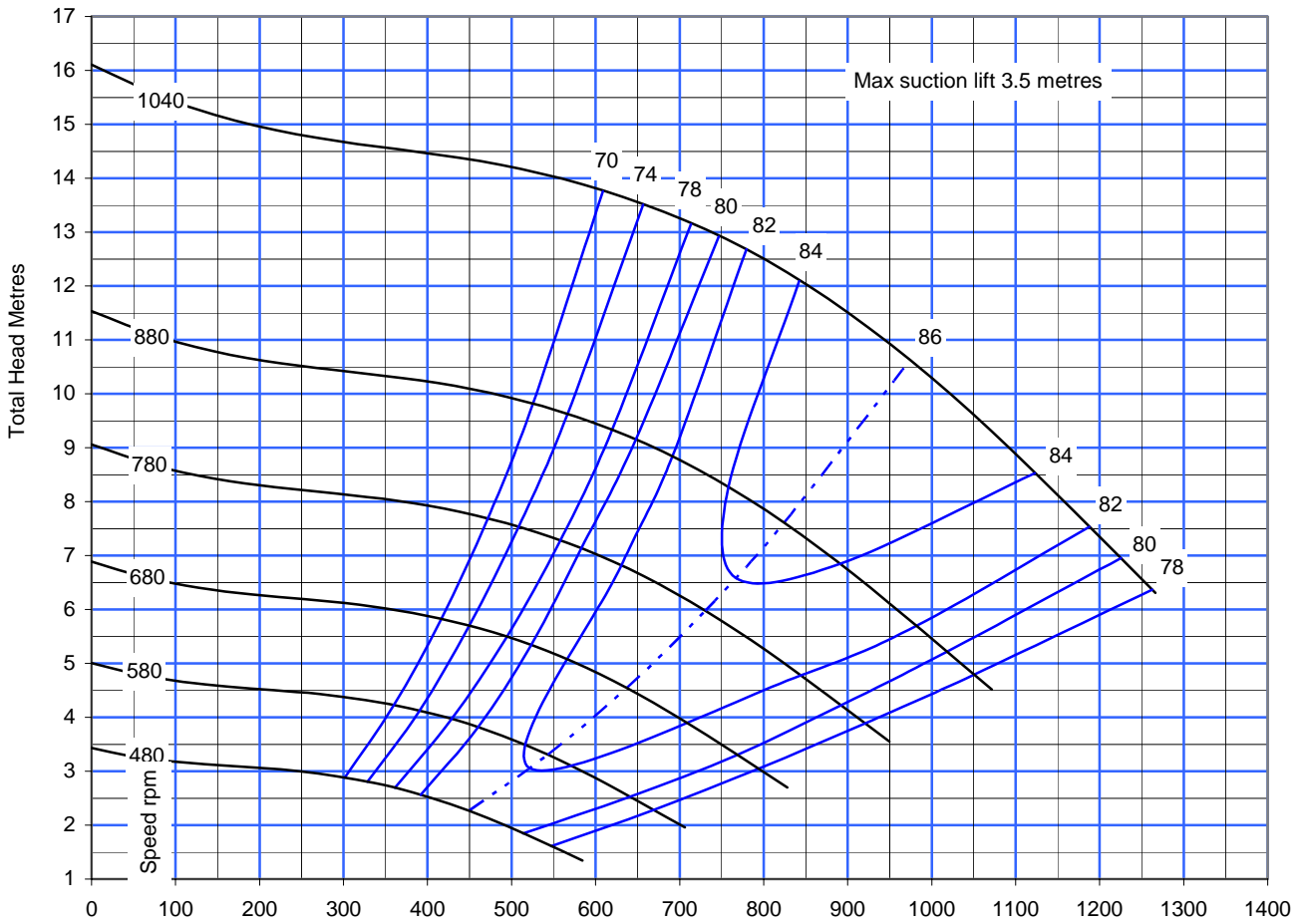

SUCTION DIA <b>350</b>	DISCHARGE DIA <b>350</b>	MAX PRESSURE <b>2 bar</b>	PUMP MODEL <b>AMF 350-8S</b>	WEIGHT <b>330 kg</b>
---------------------------	-----------------------------	------------------------------	---------------------------------	-------------------------

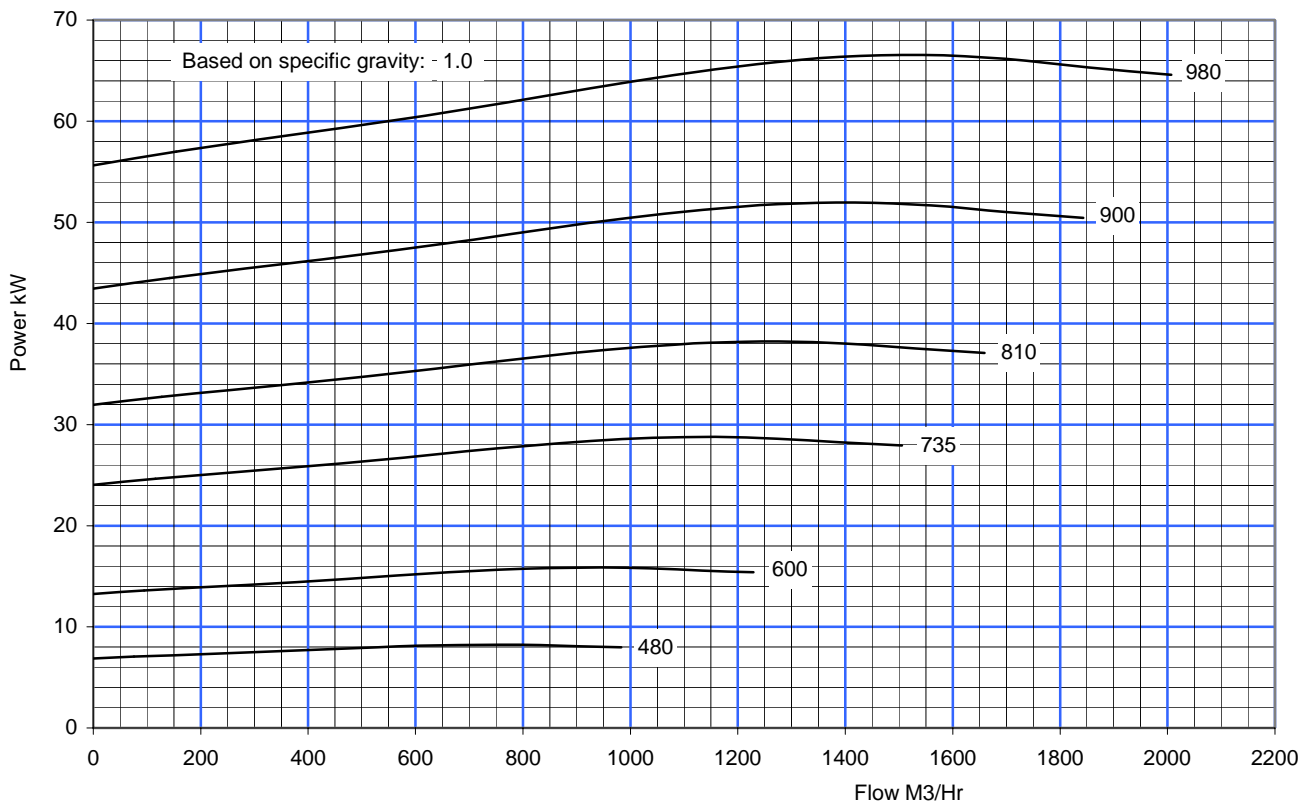
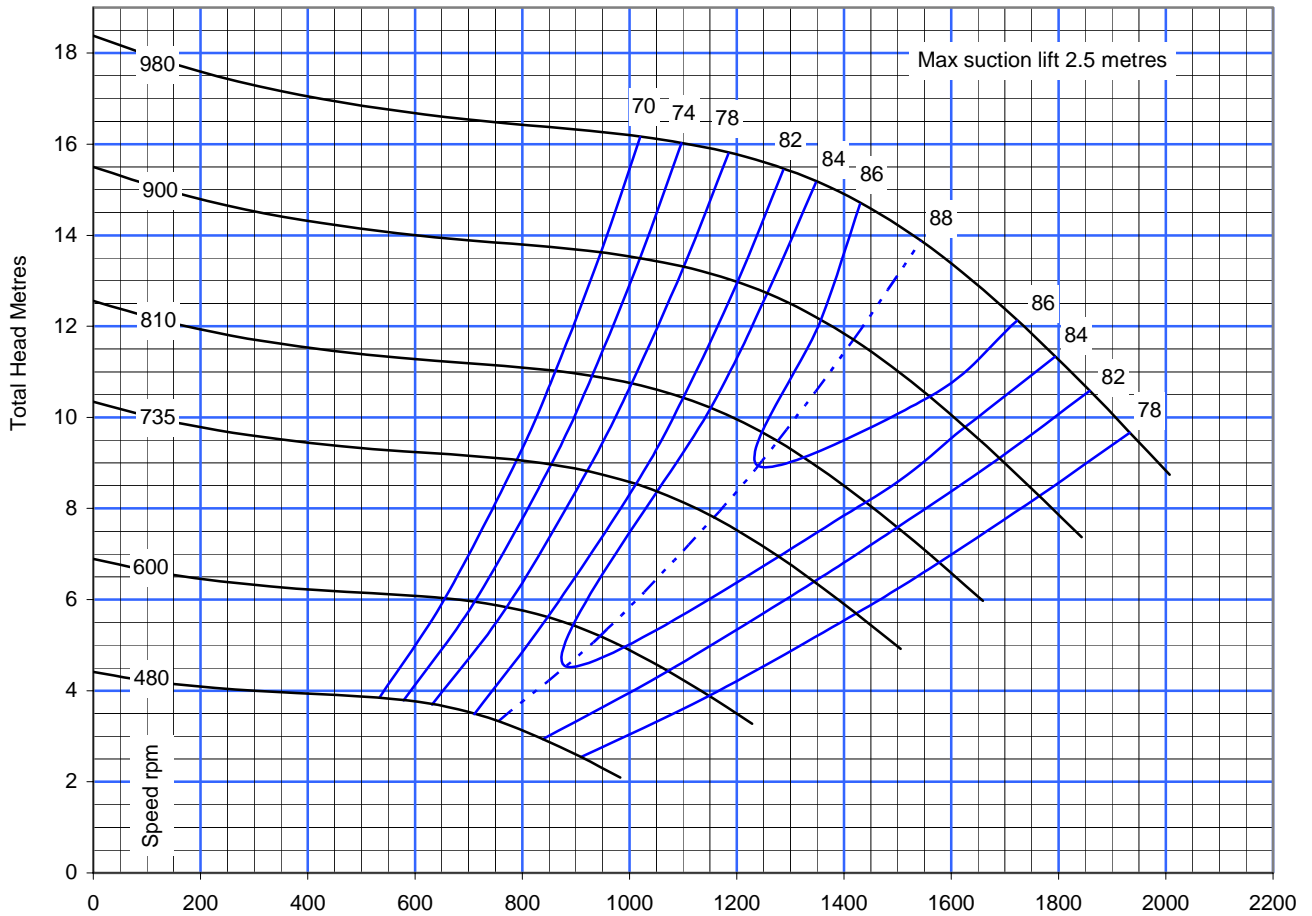

SUCTION DIA <b>400</b>	DISCHARGE DIA <b>400</b>	MAX PRESSURE <b>2 bar</b>	PUMP MODEL <b>AMF 400-7S</b>	WEIGHT <b>550 kg</b>
---------------------------	-----------------------------	------------------------------	---------------------------------	-------------------------

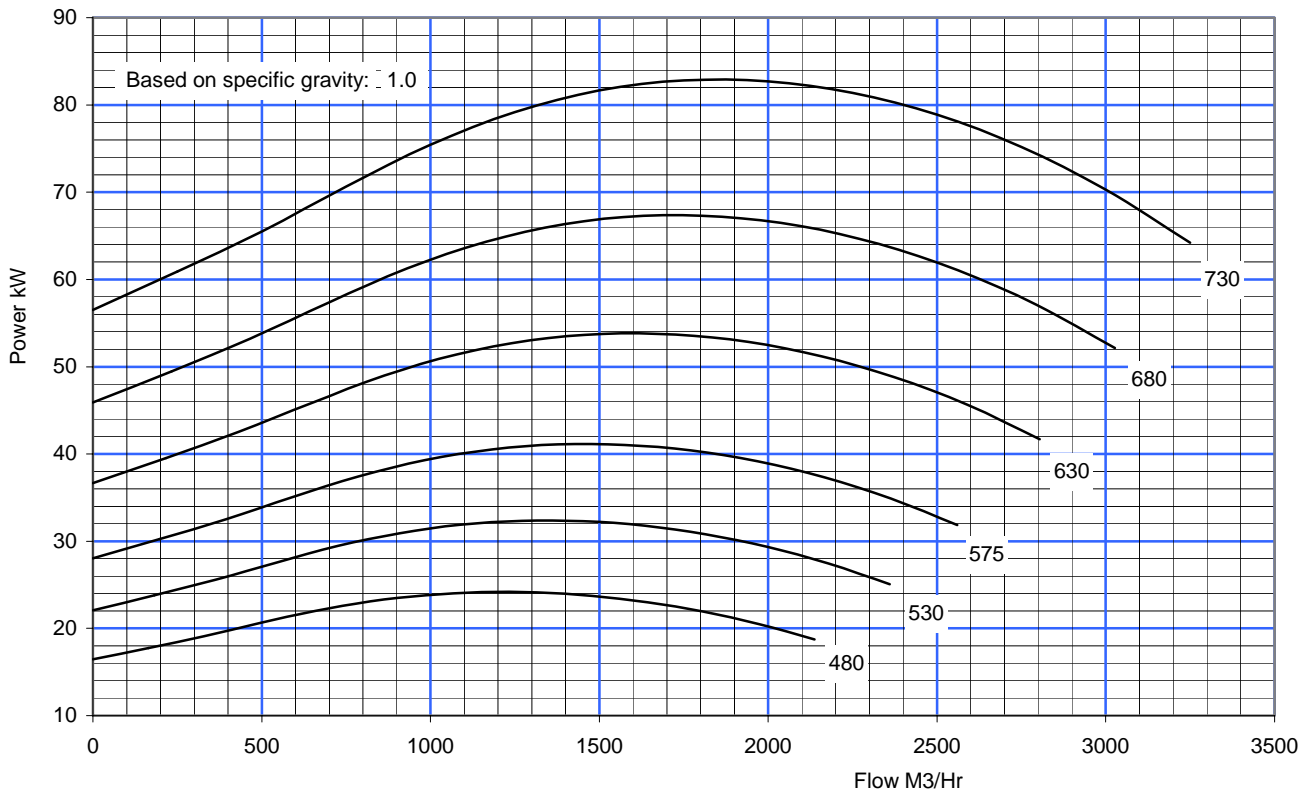
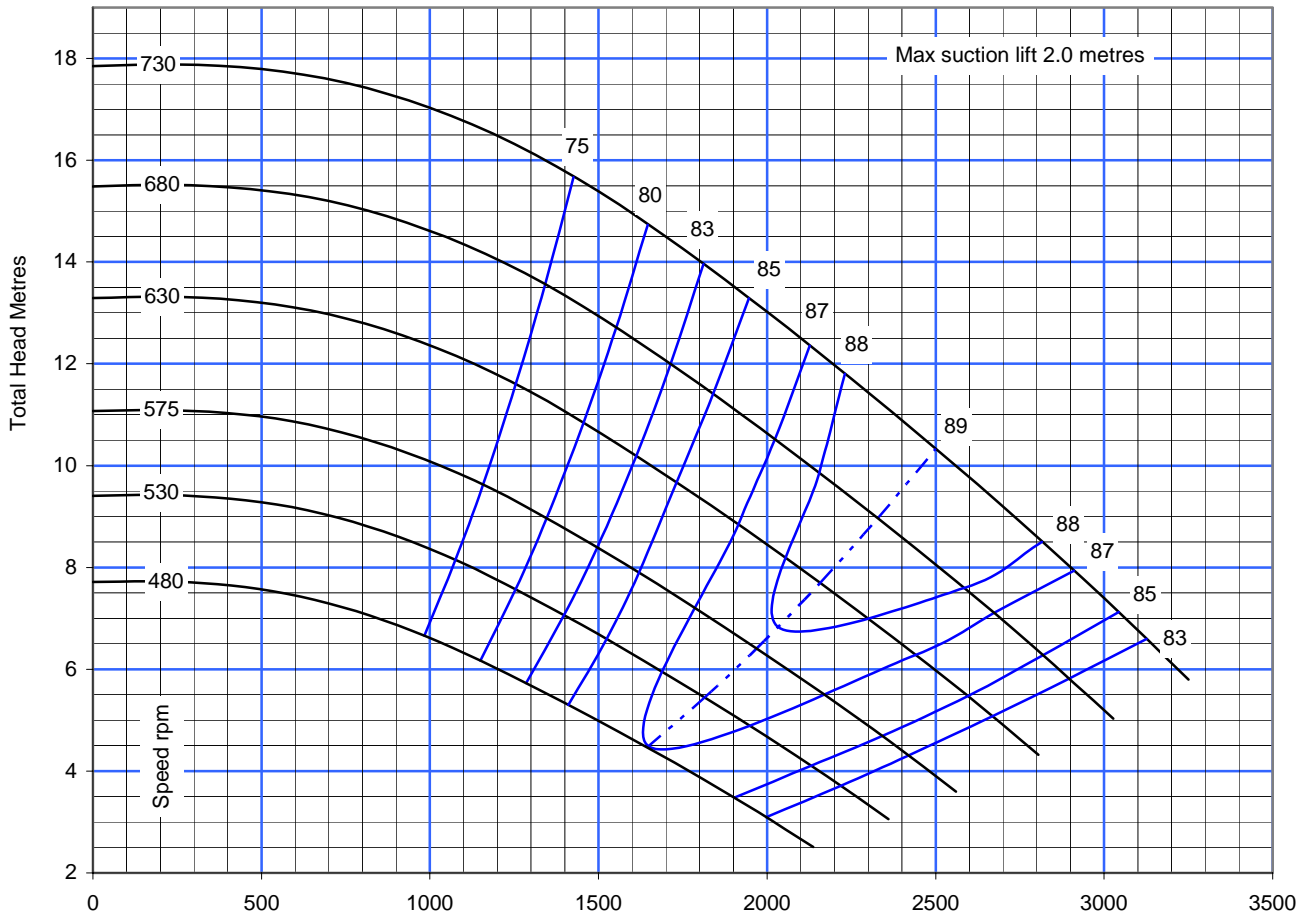

SUCTION DIA <b>500</b>	DISCHARGE DIA <b>500</b>	MAX PRESSURE <b>2 bar</b>	PUMP MODEL <b>AMF 500-6s</b>	WEIGHT <b>790 kg</b>
---------------------------	-----------------------------	------------------------------	---------------------------------	-------------------------

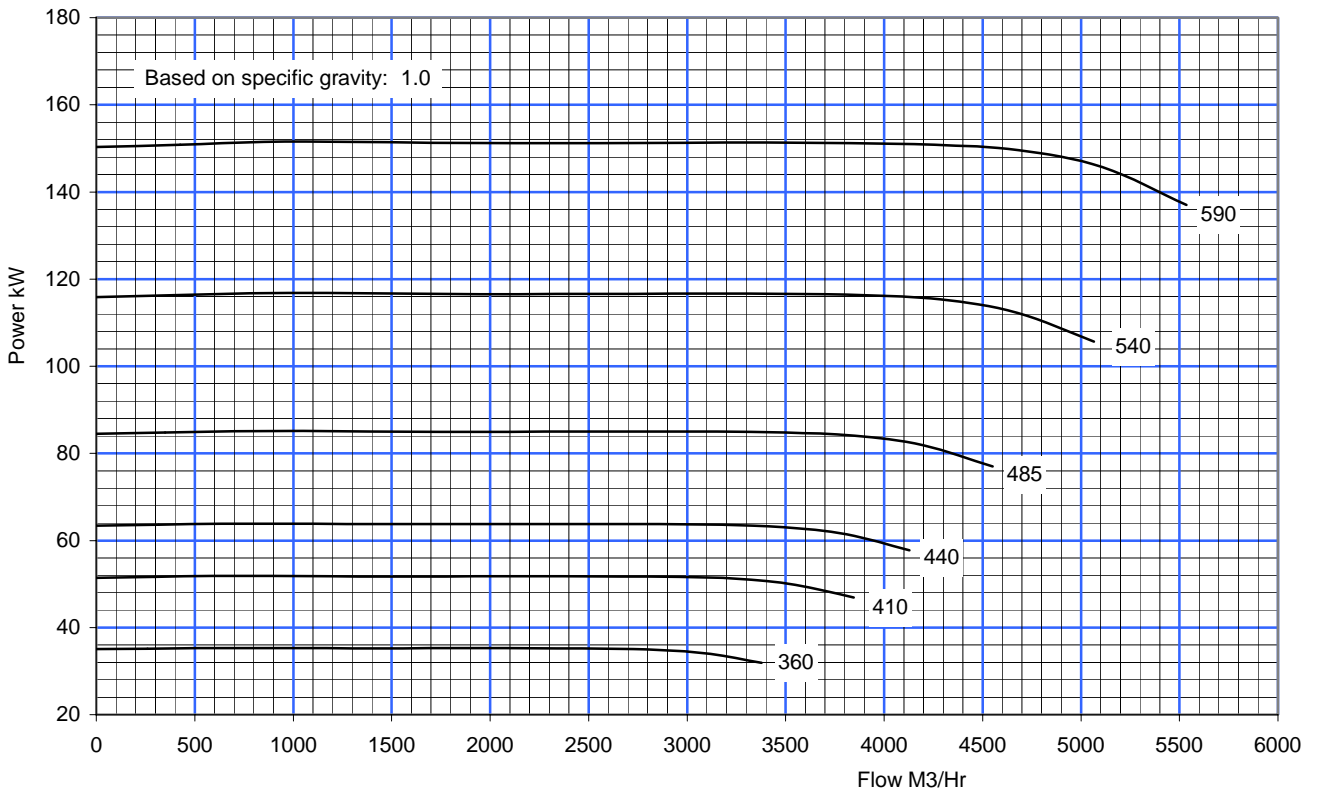
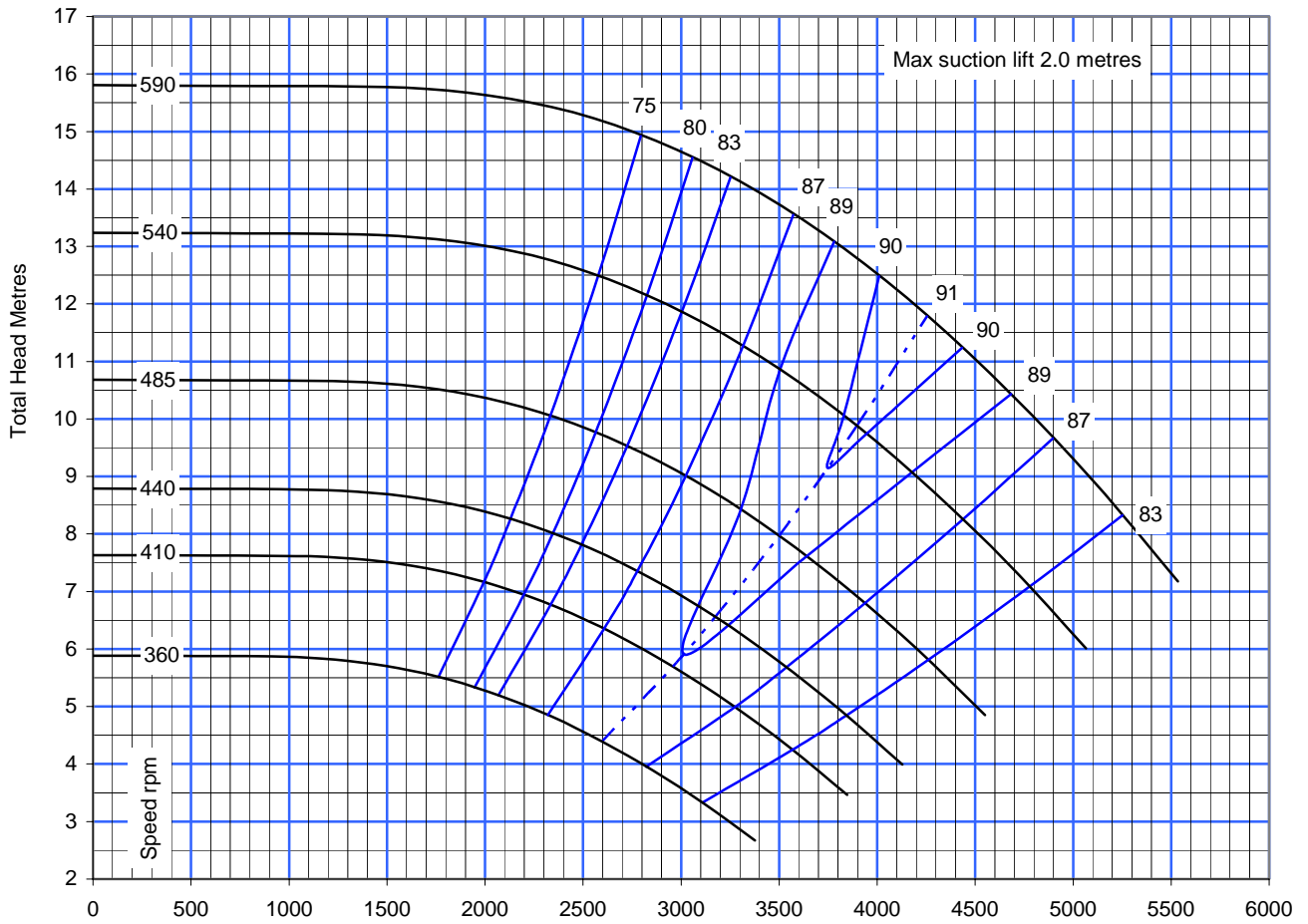

SUCTION DIA <b>700</b>	DISCHARGE DIA <b>700</b>	MAX PRESSURE <b>2 bar</b>	PUMP MODEL <b>AMF 700-7S</b>	WEIGHT <b>1800 kg</b>
---------------------------	-----------------------------	------------------------------	---------------------------------	--------------------------

## Outline dimensions (vertical discharge)

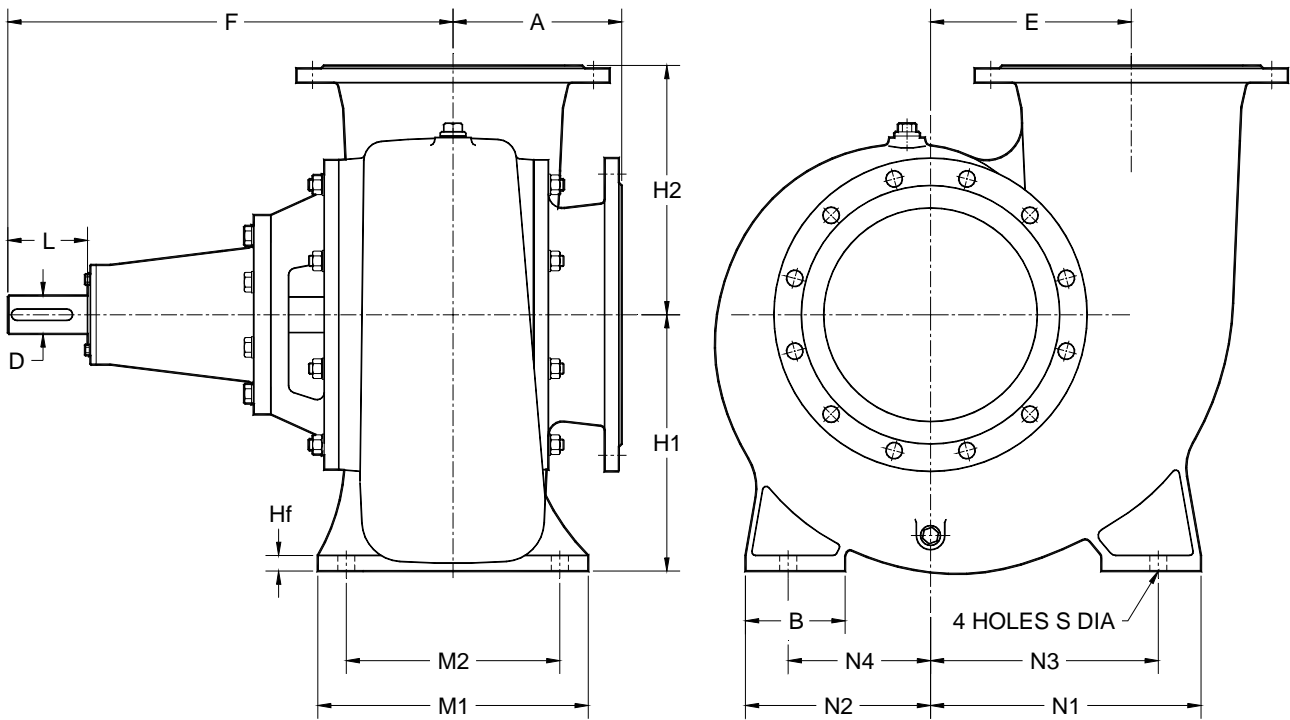

Pump Model	Outline dimensions					Mounting feet dimensions								Shaft		Mass Kg	
	A	F	H1	H2	E	N1	N2	N3	N4	B	M1	M2	Hf	S	L		D
100-8s	170	212	140	140	99	136	106	110	80	64	135	90	14	14.5	25	24	30
150-5s	137	252	195	185	148	196	134	154	92	82	210	156	16	18.5	53	30	65
200-4s	186	454	265	235	194	265	195	220	150	100	260	200	20	18	58	35	110
200-8s	186	454	265	235	194	265	195	220	150	100	260	200	20	18	58	35	110
250-4s	215	529	295	288	232	312	214	262	164	116	312	246	22	18	76	44	165
250-7s	215	529	295	288	232	312	214	262	164	116	312	246	22	18	76	44	165
250-8s	215	529	295	288	232	312	214	262	164	116	312	246	22	18	76	44	165
300-4s	236	624	360	350	282	380	260	320	200	140	380	300	22	24	107	54	195
300-7s	236	624	360	350	282	380	260	320	200	140	380	300	22	24	107	54	195
350-8s	289	640	400	380	290	400	280	320	200	160	400	300	25	24	107	54	330
400-7s	305	729	510	450	370	480	340	370	230	200	415	350	35	26	140	55	550
500-6s	330	873	580	565	400	555	395	430	270	216	500	390	32	30	160	68	790

For dimensions of engine driven pumpsets, refer to Apex Pumps.

## Outline dimensions (horizontal discharge)

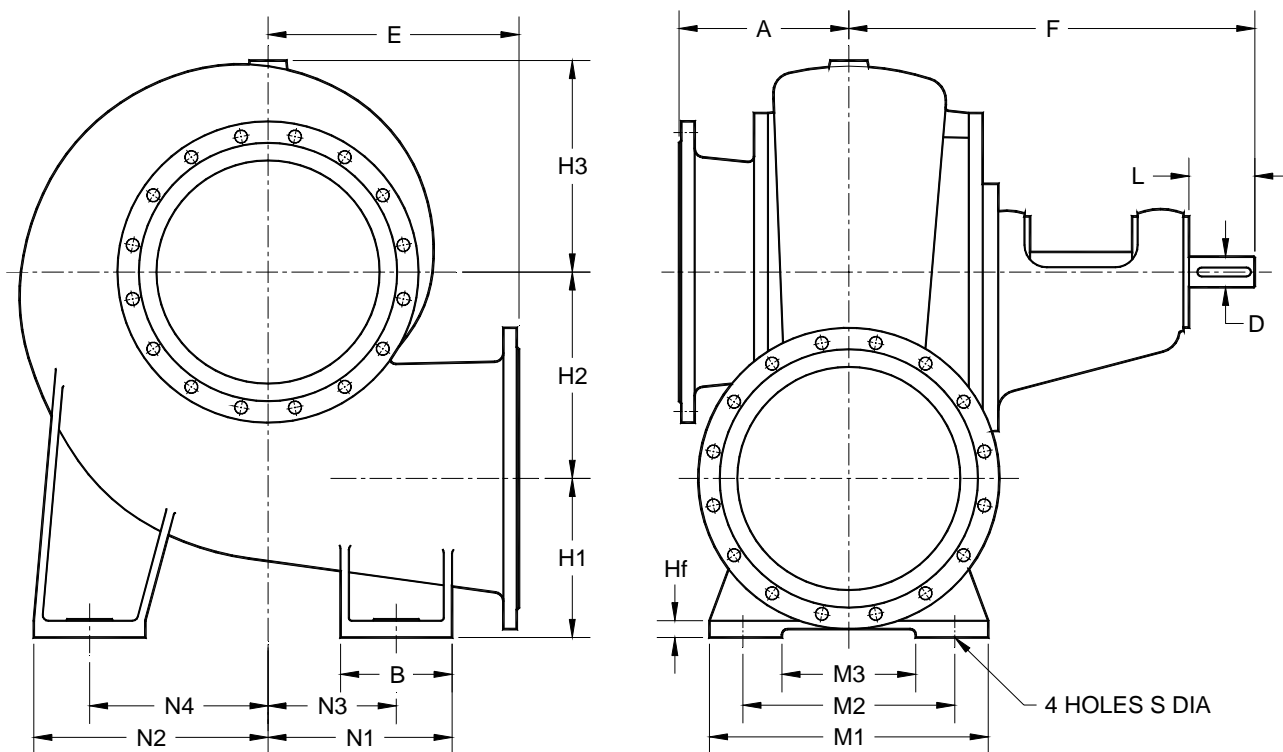

Pump Model	Outline dimensions						Mounting feet dimensions									Shaft		Mass Kg	
	A	F	H1	H2	H3	E	N1	N2	N3	N4	B	M1	M2	M3	Hf	S	L		D
350-8s	289	640	255	290	358	380	280	320	200	240	160	400	300	170	25	23	107	54	330
400-7s	305	729	285	370	427	450	330	420	230	320	200	500	380	240	35	30	108	55	550
500-6s	329	883	330	400	496	565	460	550	335	425	250	500	390	260	45	30	160	68	790
700-7s	488	1138	1000	430	670	735	585	705	430	550	310	750	580	400	50	34	133	95	1800

For dimensions of engine driven pumpsets, refer to Apex Pumps.

## Pumpset dimensions (vertical discharge)

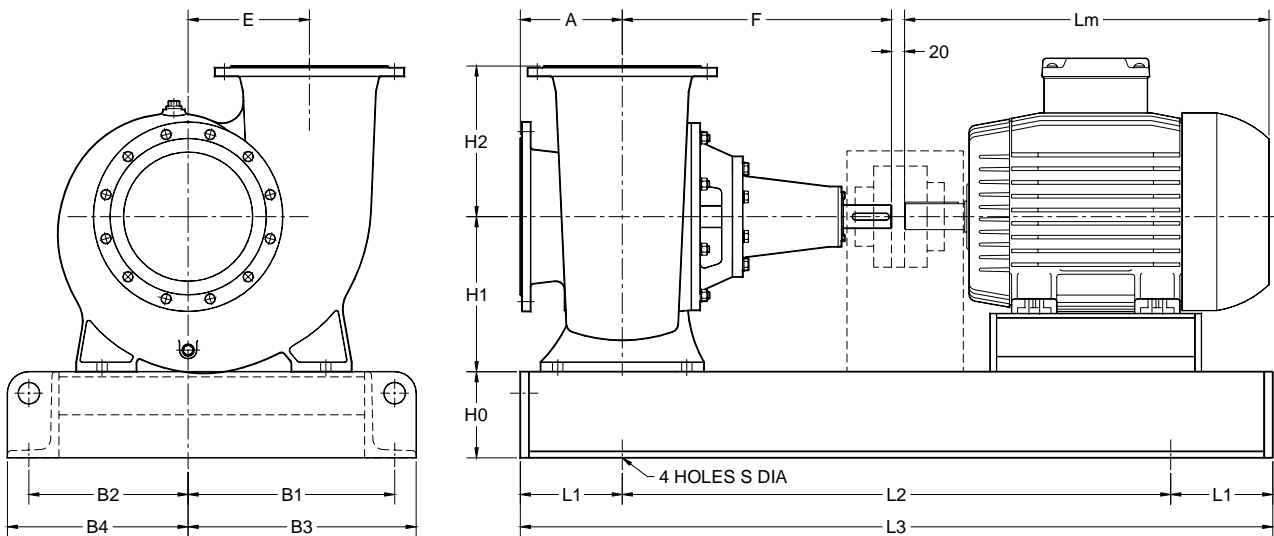

For indication only. Certified drawing issued upon request.

Pump Model	Motor	Frame size	Flanges		Pump dimensions					Bedplate dimensions									Lm	kg
			IN	OUT	A	F	E	H1	H2	H0	L1	L2	L3	B1	B2	B3	B4	S		
100-8s	4.0/2	112M	100	100	170	212	99	140	140	100	170	460	800	220	220	250	250	18	393	159
150-5s	4.0/4	112M	150	150	137	252	148	195	185	100	170	460	800	280	220	310	250	18	393	194
200-4s	15/4	160M	200	200	186	454	194	265	235	100	190	920	1300	350	280	380	310	18	598	350
200-4s	4.0/6	132S	200	200	186	454	194	265	235	100	190	820	1200	350	280	380	310	18	452	293
200-8s	7.5/6	160M	200	200	186	454	194	265	235	100	190	920	1300	350	280	380	310	18	598	350
200-8s	4.0/8	132S	200	200	186	454	194	265	235	100	190	820	1200	350	280	380	310	18	452	293
250-4s	15/6	180L	250	250	215	529	232	295	288	150	220	1060	1500	405	305	440	340	22	702	500
250-4s	5.5/8	160M	250	250	215	529	232	295	288	150	220	960	1400	405	305	440	340	22	598	415
250-7s	11/6	160L	250	250	215	529	232	295	288	150	220	960	1400	405	305	440	340	22	642	426
250-7s	5.5/8	160M	250	250	215	529	232	295	288	150	220	960	1400	405	305	440	340	22	598	415
250-8s	30/6	225S/M	250	250	215	529	232	295	288	150	220	1260	1700	405	305	440	340	22	847	715
250-8s	15/8	200L	250	250	215	529	232	295	288	150	220	1160	1600	405	305	440	340	22	767	565
300-4s	30/6	225S/M	300	300	236	624	282	360	350	150	240	1320	1800	465	355	500	390	22	847	755
300-4s	15/8	200L	300	300	236	624	282	360	350	150	240	1220	1700	465	355	500	390	22	767	605
300-7s	30/6	225S/M	300	300	236	624	282	360	350	150	240	1320	1800	465	355	500	390	22	847	755
300-7s	15/8	200L	300	300	236	624	282	360	350	150	240	1220	1700	465	355	500	390	22	767	605
350-8s	37/6	250S/M	350	350	289	640	290	400	380	200	290	1320	1900	500	380	540	420	30	923	980
350-8s	22/8	225S/M	350	350	289	640	290	400	380	200	290	1220	1800	500	380	540	420	30	847	890
400-7s	75/6	280S/M	400	400	305	729	370	510	450	200	330	1440	2100	580	440	620	480	30	1036	1555
400-7s	37/8	250S/M	400	400	305	729	370	510	450	200	330	1340	2000	580	440	620	480	30	923	1210
500-6s	90/8	315S/M	500	500	330	873	400	580	565	200	350	1700	2400	660	510	700	550	30	1156	2025

## Pumpset dimensions (horizontal discharge)

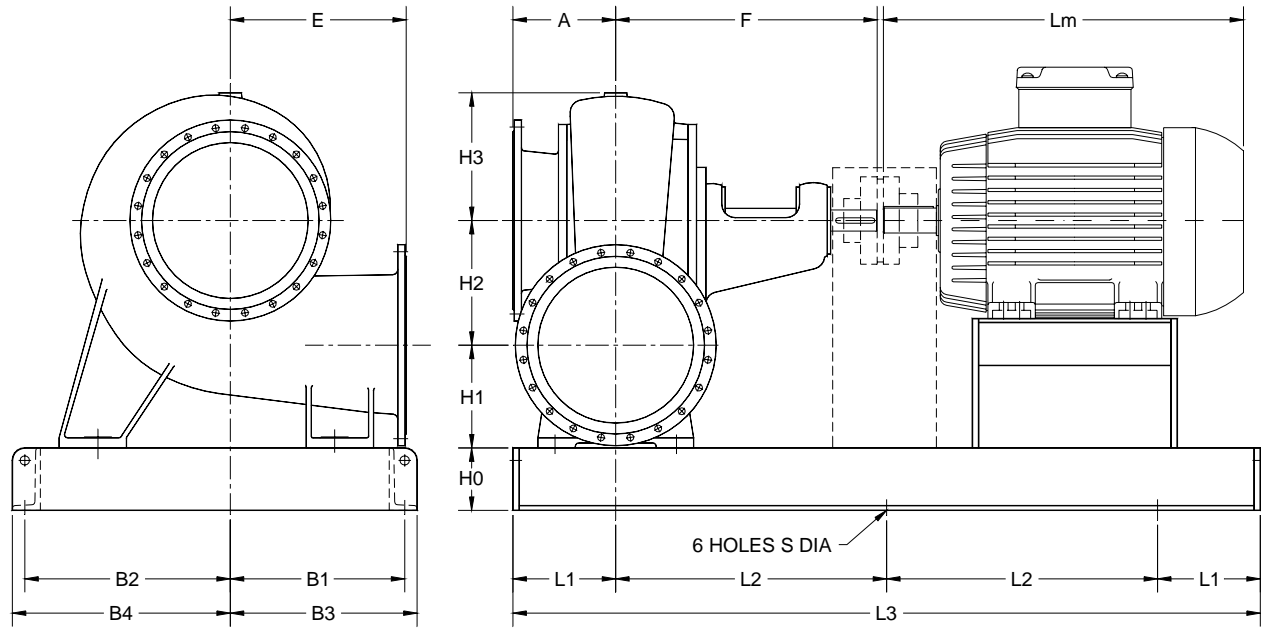

For indication only. Certified drawing issued upon request.

Pump Model	Motor	Frame size	Flanges		Pump dimensions						Bedplate dimensions						Lm	kg			
			IN	OUT	A	F	E	H1	H2	H3	H0	L1	L2	L3	B1	B2			B3	B4	S
350-8s	37/6	250S/M	350	350	289	640	380	255	290	358	200	290	660	1900	380	420	420	460	30	923	980
350-8s	22/8	225S/M	350	350	289	640	380	255	290	358	200	290	610	1800	380	420	420	460	30	847	890
400-7s	75/6	280S/M	400	400	305	729	450	285	370	427	200	330	720	2100	430	520	470	560	30	1036	1555
400-7s	37/8	250S/M	400	400	305	729	450	285	370	427	200	330	670	2000	430	520	470	560	30	923	1210
500-6s	90/8	315S/M	500	500	329	883	565	330	400	496	200	350	850	2400	560	660	600	700	30	1156	2025
700-7s	160/10	355M/L	700	700	488	1138	735	1000	430	670	200	500	1100	3200	690	810	730	850	30	1466	3970

## Parts list and inter-changeability chart

Ref	Item	Qty	100-8s	150-5s	200-4s	200-8s	250-4s	250-7s	250-8s
01	Volute casing	1	AM 0101	AM 0102	AM 0103	AM 0103	AM 0104	AM 0104	AM 0104
02	Impeller	1	AM 0281	AM 0252	AM 0243	AM 0283	AM 0244	AM0274	AM0284
03	Shaft	1	AM 0301	AM 0302	AM 0303	AM 0303	AM 0304	AM 0304	AM 0304
06	Bearing housing	1	AM 0601	AM 0602	AM 0603	AM 0603	AM 0604	AM 0604	AM 0604
08	Impeller nut	1	FX1600	FX1800	FX2000	FX2000	FX2000	FX2000	FX2000
08.1	Impeller nut washer	1	FW1600	FW1800	FW2000	FW2000	FW2000	FW2000	FW2000
10.1	Casing gasket (front)	1	AM1001	AM 1002	AM 1003	AM 1003	AM 1004	AM 1004	AM 1004
10.2	Casing gasket (rear)	1	AM1001	AM 1002	AM 1003	AM 1003	AM 1004	AM 1004	AM 1004
11	Suction cover	1	AM 1181	AM 1152	AM 1143	AM 1183	AM 1144	AM 1174	AM 1184
13.1	Impeller key	1	AM 1311	AM 1312	AM 1313	AM 1313	AM 1314	AM 1314	AM 1314
13.2	Coupling key	1	AM 1321	AM 1322	AM 1323	AM 1323	AM 1324	AM 1324	AM 1324
41.1	Bearing (non-drive end)	2	XX41-6305	XX41-6306	XX41-6308	XX41-6308	XX41-6309	XX41-6309	XX41-6309
41.2	Bearing (drive end)	1	XX41-6305	XX41-6306	XX41-6308	XX41-6308	XX41-6309	XX41-6309	XX41-6309
42	Bearing cover	2	AM 4201	AM 4202	AM 4203	AM 4203	AM 4204	AM 4204	AM 4204
P1	Casing drain plug	1	3/8"BSP	3/8"BSP	3/8"BSP	3/8"BSP	3/8"BSP	3/8"BSP	3/8"BSP
	<u>Packed gland version</u>								
04	Back cover (packing)	1	AM 0401	AM 0402	AM 0403	AM 0403	AM 0404	AM 0404	AM 0404
09	Gland	1	AM 0901	AM 0902	AM 0903	AM 0903	AM 0904	AM 0904	AM 0904
44	Shaft sleeve	1	AM 4401	AM 4402	AM 4403	AM 4403	AM 4404	AM 4404	AM 4404
51	Lantern ring	1	AM 5101	AM 5102	AM 5103	AM 5103	AM 5104	AM 5104	AM 5104
53	Gland packing	4	AM 5301	AM 5302	AM 5303	AM 5303	AM 5304	AM 5304	AM 5304
	<u>Mechanical seal version</u>								
04	Back cover (mech seal)	1	AM 0411	AM 0412	AM 0413	AM 0413	AM 0414	AM 0414	AM 0414
07	Mechanical seal	1	XX0730-AN	XX0735-AN	XX0745-AN	XX0745-AN	XX0750-AN	XX0750-AN	XX0750-AN
44	Seal sleeve	1	AM 4421	AM 4422	AM 4423	AM 4423	AM 4424	AM 4424	AM 4424
44.1	Spacer sleeve	1	AM 4411	AM 4412	AM 4413	AM 4413	AM 4414	AM 4414	AM 4414
61	O ring	1	XX61-02025	XX61-02525	XX61-03225	XX61-03225	XX61-04025	XX61-04025	XX61-04025

Ref	Item	Qty	300-4s	300-7s	350-8s (H)	350-8s (V)	400-7s	500-6s (H)	500-6s (V)	700-7s
01	Volute casing	1	AM 0105	AM 0105	AM 0106H	AM 0106V	AM 0107	AM 0108H	AM 0108V	AM 0109
02	Impeller	1	AM 0245	AM 0275	AM 0286	AM 0286	AM 0277	AM 0268	AM 0268	AM 0279
03	Shaft	1	AM 0305	AM 0305	AM 0305	AM 0305	AM 0307	AM 0308	AM 0308	AM 0309
06	Bearing housing	1	AM 0605	AM 0605	AM 0605	AM 0605	AM 0607	AM 0608	AM 0608	AM 0609
08	Impeller nut	1	FX2400	FX2400	FX2400	FX2400	FX3000	FX3000	FX3000	FX3600
08.1	Impeller nut washer	1	FW2400	FW2400	FW2400	FW2400	FW3000	FW3000	FW3000	FW3600
10.1	Casing gasket (front)	1	AM 1005	AM 1005	AM 1006	AM 1006	AM 1007	AM 1008	AM 1008	AM 1009
10.2	Casing gasket (rear)	1	AM 1005	AM 1005	AM 1006	AM 1006	AM 1007	AM 1008	AM 1008	AM 1009
11	Suction cover	1	AM 1145	AM 1175	AM1186	AM 1186	AM 1177	AM 1168	AM 1168	AM 1179
13.1	Impeller key	1	AM 1315	AM 1315	AM 1315	AM 1315	AM 1317	AM 1318	AM 1318	AM 1319
13.2	Coupling key	1	AM 1325	AM 1325	AM 1325	AM 1325	AM 1327	AM 1328	AM 1328	AM 1329
41.1	Bearing (non-drive end)	2	XX41-6311	XX41-6311	XX41-6311	XX41-6311	XX41-6312	XX41-6314	XX41-6314	XX41-6322
41.2	Bearing (drive end)	1	XX41-6311	XX41-6311	XX41-6311	XX41-6311	XX41-6312	XX41-6314	XX41-6314	XX41-6322
42	Bearing cover	4	AM 4205	AM 4205	AM 4205	AM 4205	AM 4207	AM 4208	AM 4208	AM 4209
P1	Casing drain plug	1	3/8"BSP	3/8"BSP	3/8"BSP	3/8"BSP	3/8"BSP	3/8"BSP	3/8"BSP	3/8"BSP
	<u>Packed gland version</u>									
04	Back cover	1	AM 0405	AM 0405	AM 0405	AM 0405	AM 0407	AM 0408	AM 0408	AM 0409
09	Gland	1	AM 0905	AM 0905	AM 0905	AM 0905	AM 0907	AM 0908	AM 0908	AM 0909
44	Shaft sleeve	1	AM 4405	AM 4405	AM 4405	AM 4405	AM 4407	AM 4408	AM 4408	AM 4409
51	Lantern ring	1	AM 5105	AM 5105	AM 5105	AM 5105	AM 5107	AM 5108	AM 5108	AM 5109
53	Gland packing	4	AM 5305	AM 5305	AM 5305	AM 5305	AM 5307	AM 5308	AM 5308	AM 5309
	<u>Mechanical seal version</u>									
04	Back cover (mech seal)	1	AM 0415	AM 0415	AM 0415	AM 0415	AM 0417	AM 0418	AM 0418	AM 0419
07	Mechanical seal	1	XX0755-AN	XX0755-AN	XX0755-AN	XX0755-AN	XX0760-AN	XX0765-AN	XX0765-AN	XX07100
44	Seal sleeve	1	AM 4425	AM 4425	AM 4425	AM 4425	AM 4427	AM 4428	AM 4428	AM 4429
44.1	Spacer sleeve	1	AM 4415	AM 4415	AM 4415	AM 4415	AM 4417	AM 4418	AM 4418	AM 4419
61	O ring	1	XX61-04525	XX61-04525	XX61-04525	XX61-04525	XX61-05025	XX61-05525	XX61-05525	XX61-09025

## Notes

## Other Apex Products

Apex Pumps specialise in the design and manufacture of centrifugal pumps for industrial, process, building services and agricultural applications.

- End suction close coupled pumpsets to DIN 24255 standard
- End suction bareshaft pump to DIN 24255 standard
- Long coupled pumpsets to DIN 24255
- Engine driven end suction pumps
- ISO 2858 standard close coupled pumps
- ISO 2858 standard long coupled pumpsets
- Pressed stainless steel end suction pumps
- Vertical In-Line close coupled pumps
- Vertical In-Line long coupled pumps with spacer coupling
- Horizontal and vertical split casing single stage pumps
- Horizontal and vertical split casing two stage pumps
- Horizontal and vertical multistage pumps
- Tank top pumps
- Vertical trunk pumps
- Belt drive pumps

## Technical advice

At Apex we are pleased to provide advice on any pumping application without obligation. Contact our technical sales office to discuss your requirements.

Apex Fluid Engineering Ltd  
Morley Road,  
Staple Hill,  
Bristol,  
BS16 4QT  
United Kingdom

**Tel: 0117 907 7555**  
**Fax: 0117 907 7556**

Email: [enquiries@apexpumps.com](mailto:enquiries@apexpumps.com)  
Web site: [www.apexpumps.com](http://www.apexpumps.com)

International tel: +44 117 907 7555  
International fax: +44 117 907 7556